

# FURUNO

# INSTALLATION MANUAL

VHF RADIOTELEPHONE

MODEL FM-8800D/8800S



**FURUNO ELECTRIC CO., LTD.**  
NISHINOMIYA, JAPAN



(Elemental Chlorine Free)

The paper used in this manual  
is elemental chlorine free.

© **FURUNO ELECTRIC CO., LTD.**

9-52 Ashihara-cho,  
Nishinomiya 662-8580, JAPAN

Telephone : 0798-65-2111

Fax : 0798-65-4200

Your Local Agent/Dealer

All rights reserved.

Printed in Japan

Pub. No. IME-56420-A4

( TATA ) FM-8800D/S

FIRST EDITION : SEP. 2004

A4 :MAR. 04, 2005



\* 0 0 0 1 4 9 9 3 2 0 0 \*



\* I M E 5 6 4 2 0 A 4 0 \*



# SAFETY INSTRUCTIONS

## WARNING



**Hazardous voltage.  
Can shock, burn or cause  
serious injury.**

Do not work inside the equipment unless totally familiar with electrical circuits.



**Do not approach the antenna  
closer than 0.9 m (MPE by  
FCC) when it is transmitting.**

The antenna emits radio waves which can be harmful to the human body.

	RF power density on antenna aperture	Distance	Description required by
FM-8800S	100 W/m <sup>2</sup>	0.11 m	IEC 60945
	10 W/m <sup>2</sup>	0.33 m	IEC 60945
	2 W/m <sup>2</sup>	0.9 m	MPE by FCC
FM-8800D	100 W/m <sup>2</sup>	0.11 m	IEC 60945
	10 W/m <sup>2</sup>	0.33 m	IEC 60945
	2 W/m <sup>2</sup>	0.9 m	MPE by FCC

(MPE: Minimum Permissible Exposure)

**Turn off the power at the mains switchboard before beginning the installation. Post a warning sign near the switchboard to indicate that power should not be applied while the equipment is being installed.**

Electrical shock, serious injury or fire can result if the power is not turned off or is applied while the equipment is being installed.

## CAUTION



**Attach securely protective  
earth to the ship's body.**

The protective earth (grounding) is required to the AC/DC power supply unit to prevent electrical shock.

**Confirm that the power supply voltage  
is compatible with the voltage rating  
of the equipment.**

Connection to the wrong power supply can cause fire or equipment damage. The voltage rating appears on the label at the rear of the display unit.

**Observe the compass safe distance to  
prevent deviation of a magnetic  
compass.**

	Standard compass	Steering compass
FM-8800S	1.45 m	0.90 m
FM-8800D	1.45 m	0.95 m
IF-8810	0.85 m	0.55 m
IF-8820	0.75 m	0.50 m
HS-2003	1.50 m	0.95 m
HS-8800	0.40 m	0.30 m
RB-8800 (W/HS-8800)	1.20 m	0.80 m
RB-8810 (W/HS-8800)	1.50 m	1.00 m
PR-240-CE	0.90 m	0.60 m

# TABLE OF CONTENTS

---

SYSTEM CONFIGURATION..... iii

EQUIPMENT LISTS ..... iv

1. MOUNTING ..... 1-1

2. CONNECTIONS ..... 2-1

OUTLINE DRAWINGS..... D-1

INTERCONNECTION DIAGRAM .....S-1

# SYSTEM CONFIGURATION

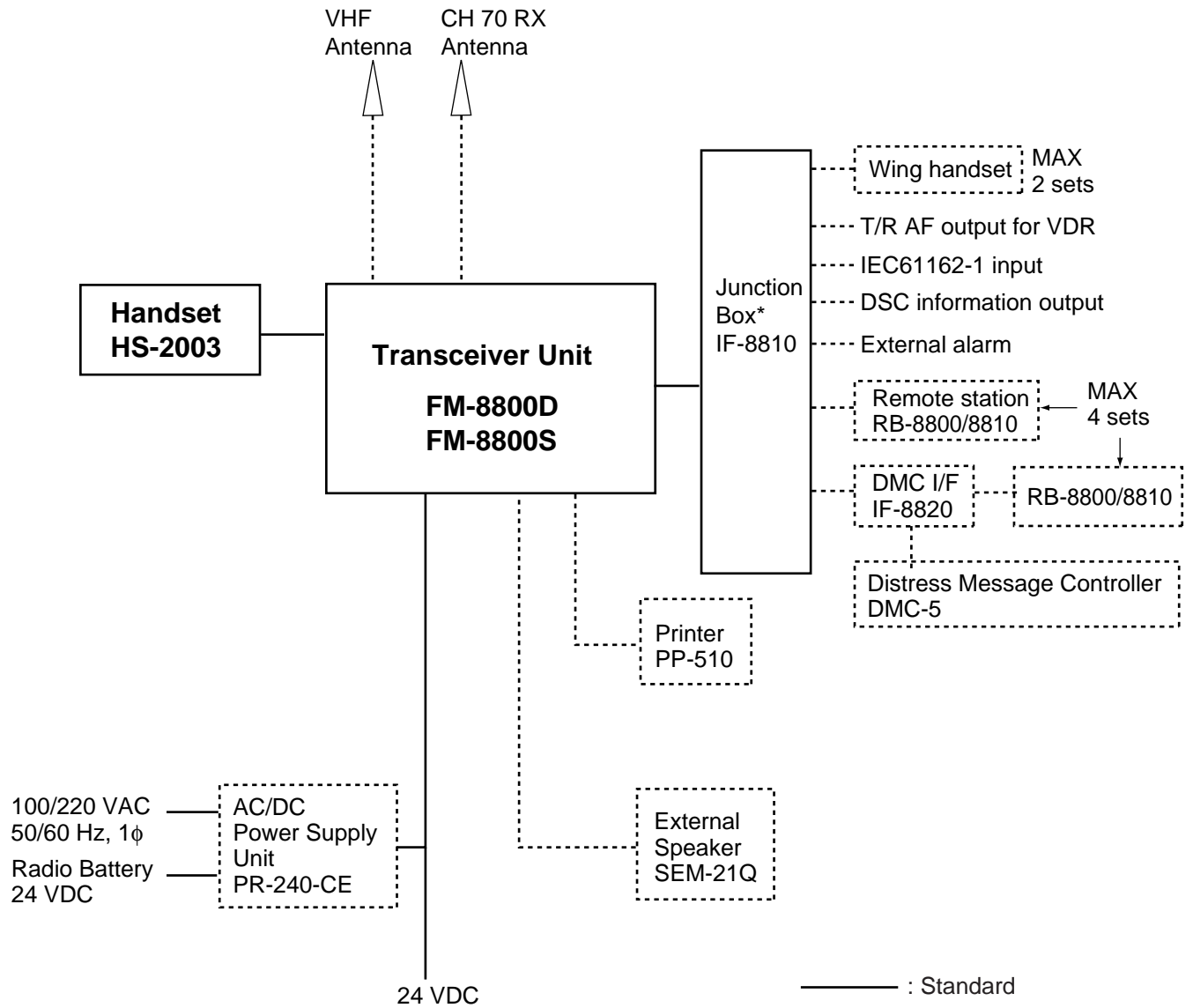

## Category of units

Unit	Category
Antenna	Exposed to weather
All other units	Protected from weather

\*: Option for FM-8800S/D-N

# EQUIPMENT LISTS

## Standard Supply

	Name	Type	Qty	Code No.	Remarks
1	Transceiver Unit	FM-8800D-E-A	1	—	D: Duplex S: Simplex E: With handset HS-2003 F: With microphone DM-2003-F A: With IF-8810 N: No IF-8810
		FM-8800D-E-N			
		FM-8800D-F-A			
		FM-8800D-F-N			
		FM-8800S-E-A			
		FM-8800S-E-N			
		FM-8800S-F-A			
		FM-8800S-F-N			
2	Accessories*	FP05-05700	1	000-054-228	<u>For E-type</u> Handset HS-2003, Hanger FP05-05510, Others FP05-05511
		FP05-05710		000-054-156	<u>For F-type</u> Microphone DM-2003-F
3	Junction Box	IF-8810	1	—	For A-type
4	Installation Materials*	CP05-09900	1	000-054-227	Power cable 05S9371, CP05-09901
5	Spare Parts*	SP05-05501	1	005-377-820	

## Optional Equipment

Name	Type	Code No.	Remarks
Flush Mount Kit	OP05-102	000-054-120	
Junction Box	IF-8810	—	W/ Screw 5x20 4 pcs.
DMC Interface	IF-8820	—	W/ Screw 5x20 4 pcs.
Remote Station	RB-8800	—	·FP05-05701*, ·Handset HS-8800, ·Hanger W/DIST. button HG-8800
	RB-8810	—	·FP05-05511*, ·Handset HS-8800, ·Hanger HG-8810
Handset	HS-8800	000-054-230	
	HS-2003	000-054-223	
	HS-6000FZ11	000-135-072	
Handset Hanger	HG-8800	000-054-229	For HS-8800
	HG-8810	000-054-231	For HS-8800
	FP05-05510	005-951-790	For HS-2003
	AP-102	000-580-019	For HS-6000FZ11
Loudspeaker	SEM-21Q	000-144-917	

\*: See lists at the end of this manual.

Name	Type	Code No.	Remarks
Dynamic Mic. Set	OP05-57	000-045-775	Handset HS-6000FZ5, Receptacle RDB-VHF(B), Hanger AP-102
Carbon Mic. Set	OP05-58	000-045-776	Handset HS-6000FZ6, Receptacle RDB-VHF, Hanger AP-102
Handset set	OP05-42	000-045-778	Handset HS-6000FZ11, Receptacle RDB-VHF(B), Hanger AP-102
Mic. Receptacle Box	RBD-VHF (B)	000-056-094	
Microphone	DM-2003-F	005-377-760	
Printer	PP-510	—	
Printer Interface	IF-8500	—	
AC-DC Power Supply	PR-240-CE	—	
Antenna Material	AP05-00800	000-057-721	Whip antenna FAB-151D, Mounting plate 4-310071, Coax. Cable 5D-2V 10m, Connector M-P-5 2 PCS
	AP05-00810	000-057-722	Whip antenna RA106, Mounting plate RA115, Coax. Cable 05S9104 5m,
	AP05-00900	000-057-739	Whip antenna 396-1, Mounting plate 4187,
	AP05-01000	000-054-123	Whip antenna FAB-151D, Mounting plate 4-310071, Connector M-P-7 2 PCS
	AP05-01100	000-054-224	Whip antenna 150M-W2VN, Coax. Cable 5D-2V 10m, Connector M-P-5 2 PCS
	AP05-01200	000-054-232	Whip antenna FAB-151D, Mounting plate 4-310071, Coax. Cable 5D-2V 10m, Connector M-P-5 & M-P-7
	AP05-01210	000-054-233	Whip antenna FAB-151D, Mounting plate 4-310071, Coax. Cable 5D-2V 20m, Connector M-P-5 & M-P-7
Signal Cable	05S0309 *10M*	000-106-043	10m
	05S0309 *20M*	000-106-044	20m
	05S0309 *30M*	000-106-046	30m
	05S0309 *40M*	000-106-047	40m
	05S0309 *50M*	000-106-048	50m
Twisted Cable	CO-SPEVV-SB-C 0.2x2P	000-111-680	5m
		000-120-792	10m
		000-120-793	15m
		000-120-794	20m
		000-120-214	30m

This page is intentionally left blank.



# 1. MOUNTING

---

## Transceiver Unit

### General mounting considerations

Determine the mounting location for the transceiver unit considering operator convenience, proximity to the power source and the ground location. Keep these and the following points in mind when selecting a mounting location.

- Locate the unit in a place free of water spray and water splash.
- Keep the unit out of direct sunlight because of heat that can build up inside the unit.
- Leave a little slack in cables to allow a service technician to move the radio from its usual location with the cables connected. This lets him make tuning and other adjustments on a “live” set.
- Do not install the unit where flammable gases are stored.
- Select a well-ventilated area.
- Ensure the mounting location is strong enough to support the weight of the unit (approx. 6 kg) under the condition of continued vibration normally encountered aboard the vessel. If necessary, reinforce the mounting area with a doubling plate or lining block.
- Leave sufficient space at the sides and rear of the unit for maintenance and service purposes and to provide for circulation of cooling air. See outlines drawings at the back of this manual.
- **For flush mounting**, select a location where the LCD can be easily viewed.
- The transceiver unit will affect a magnetic compass if placed too near the compass. Observe the compass safe distance to prevent deviation of a magnetic compass, referring to page “ i ”.

**Note:** Take great care not to press the DISTRESS switch during the installation. If you accidentally press the switch, immediately turn off the equipment and contact appropriate authority by telephone.

### Overview of mounting methods

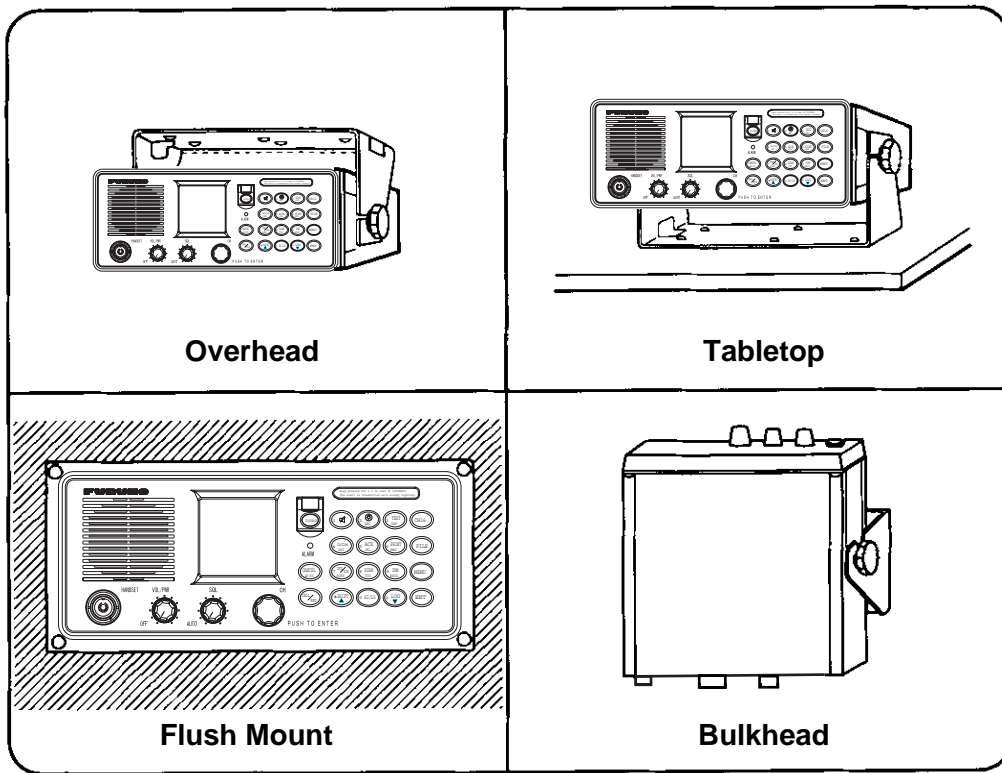

*Overview of mounting methods*

## Mounting procedure for tabletop, overhead and bulkhead mounting

1. Using the hanger as a template, mark fixing holes in the mounting location.
2. Fix the hanger to the mounting location with self-tapping screws and washers (supplied).  
(For added support, use nuts, bolts and washers instead of self-tapping screws.)
3. Screw the knob bolts with washers into the transceiver unit.
4. Set the transceiver unit to the hanger and tighten knob bolts.

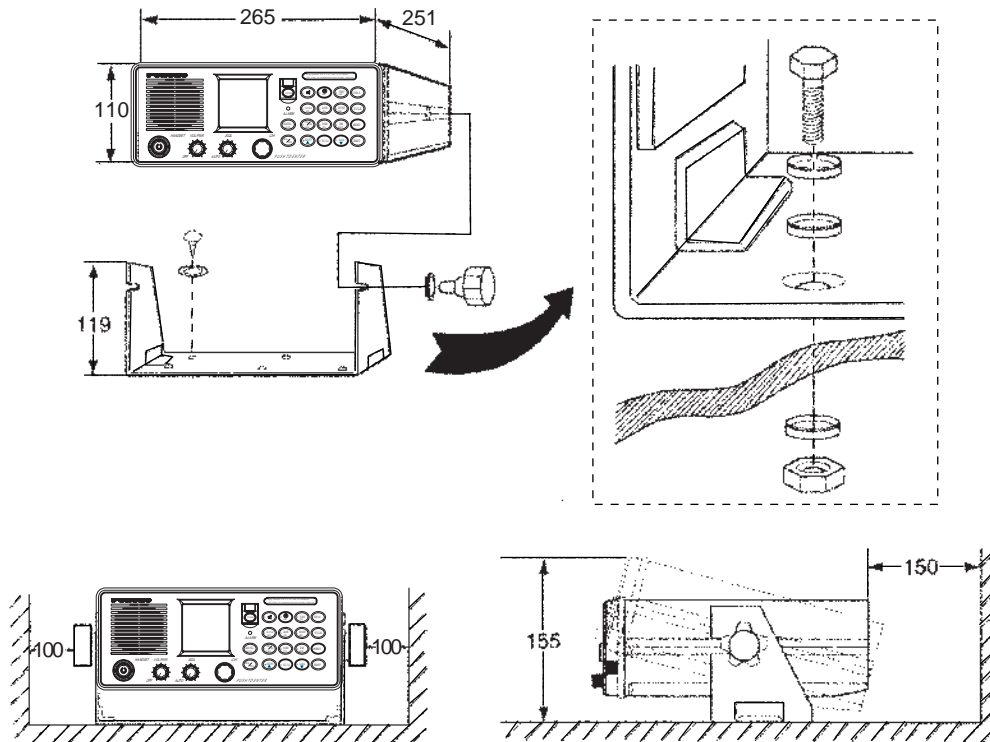

- All dimensions in millimeters.
- Leave sufficient space at the sides and rear of the unit to provide easy access for maintenance and service.

*Mounting dimensions for tabletop, overhead and bulkhead mounting*

## 1. MOUNTING

### Mounting procedure for flush mount (option)

Requires optional flush mount kit OP05-102 (Code No. 000-054-120). Prepare a cutout in the mounting location whose dimensions are as shown in the figure below.

#### Flush mount kit OP05-102

	Name	Type	Code No.	Qty
1	Mounting plate	05-093-1211	100-323-160	1
2	Self-tapping screw	5x20	000-802-081	4
3	Hex screw	M8x16	000-882-075	2

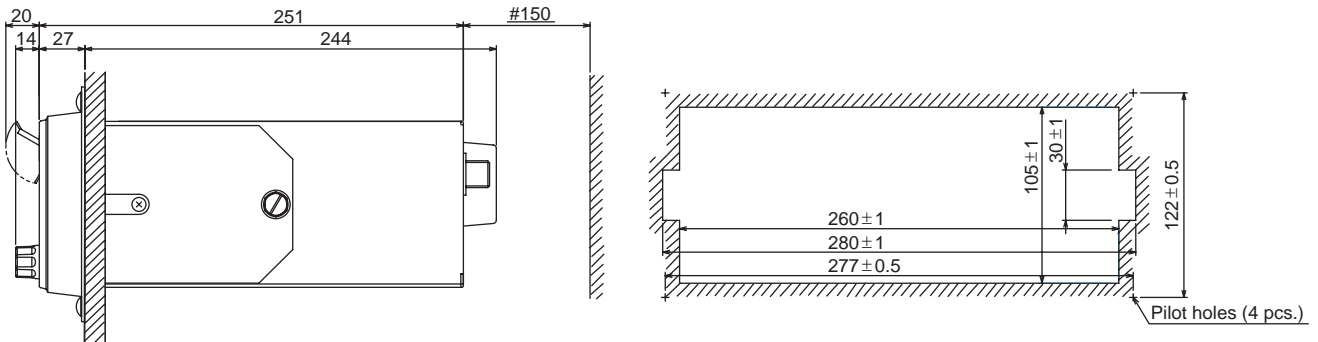

*Mounting dimensions for flush mount*

## VHF Antenna

### The antenna requirements

Any good quality antenna meeting the requirements shown below may be used. A high-gain antenna is preferable.

- Frequency range: 155 to 164 MHz
- Impedance: 50 ohms
- Polarization: Vertical
- Handling power: 30 W/ min
- Quality: Able to withstand marine environment

### Mounting considerations

- The antenna should be well separated from nearby antennas, masts, and other interfering objects.
- The higher the antenna is mounted above the horizon, the further the communications range.

### Mounting procedure

The basic mounting procedure for antennas supplied by FURUNO is as follows, however consult appropriate outline drawing for details.

1. Fasten the antenna bracket to the stanchion.
2. Set the antenna to the antenna bracket and tighten bolts.
3. Screw the coaxial cable plug into the antenna.

## CH70 RX Antenna

The antenna should be well separated from nearby antennas, masts, and other interfering objects.

The mounting procedure is the same as that for the VHF antenna, however consult appropriate outline drawing for details.

## Handset Hanger

The handset hanger can be mounted at the left side of the transceiver unit. The mounting location should provide easy access to front panel controls while operating the handset. Also, the length of the standard handset cable is 50 cm, so locate the handset hanger within 50 cm of the unit. (Longer cables are available optionally.)

## Power Supply (option)

For Convention vessels, both AC and DC power must be fed to the FM-8800D/8800S, via an AC/DC power supply. When AC input fails, DC power is supplied. FURUNO can supply an AC/DC power supply unit, the PR-240-CE.

## Mounting considerations

When selecting a mounting location, keep in mind the following points.

- Select a location which provides adequate ventilation.
- The location must be clean and dry.
- The mounting location must be able to support the weight of the unit (14.5 kg) under the continued conditions of vibration normally encountered aboard the vessel. If necessary, reinforce the mounting location.
- The PR-240-CE will affect a magnetic compass if it is placed too near the compass. Observe the compass safe distance to prevent deviation of a magnetic compass, referring to page “i”.

## Mounting

Refer to outline drawing.

## 1. MOUNTING

### Printer (option)

Printer PP-510 can be connected to the transceiver unit. To mount the printer, refer to the printer outline drawing at the back of this manual.

1. Select a flat surface.
2. Fix the mounting base to the mounting location with four screws (supplied).
3. Lay the printer on the top of the mounting base and fasten it with the mounting fixtures (two at each side and one at rear).

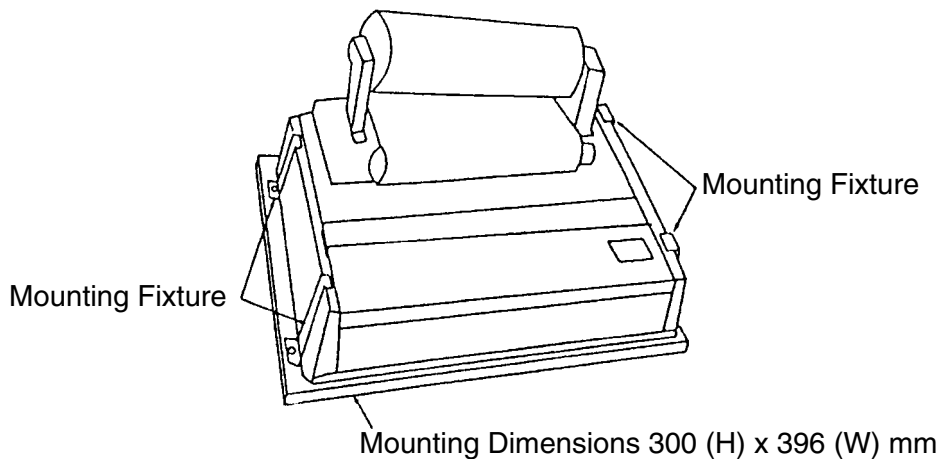

*Mounting of Printer PP-510*

### Printer Interface (option)

The printer interface IF-8500 is required for the printer PP-510 which is commonly used with the FM-8800D/S and other MF/HF radio communication equipment. To mount the unit, see the outline drawing at the back of this manual.

### External Loudspeaker (option)

The external loudspeaker can be installed on a tabletop, the overhead or a bulkhead. Fasten the loudspeaker to the mounting location with self-tapping screws, or nuts, bolts and washers. For mounting dimensions, see the outline drawing at the back of this manual.

## Junction box IF-8810/ DMC interface IF-8820

To install the remote box RB-8800/RB-8810, wing handset, etc., the junction box IF-8810 is required. Install the junction box near the transceiver unit. Approx. 3 m cable is preattached to the junction box to connect to the transceiver unit.

To connect Furuno's distress message controller DMC-5, the DMC interface IF-8820 (option) is required.

1. Open the cover.
2. Mount the unit with four self-tapping screws (5x20).

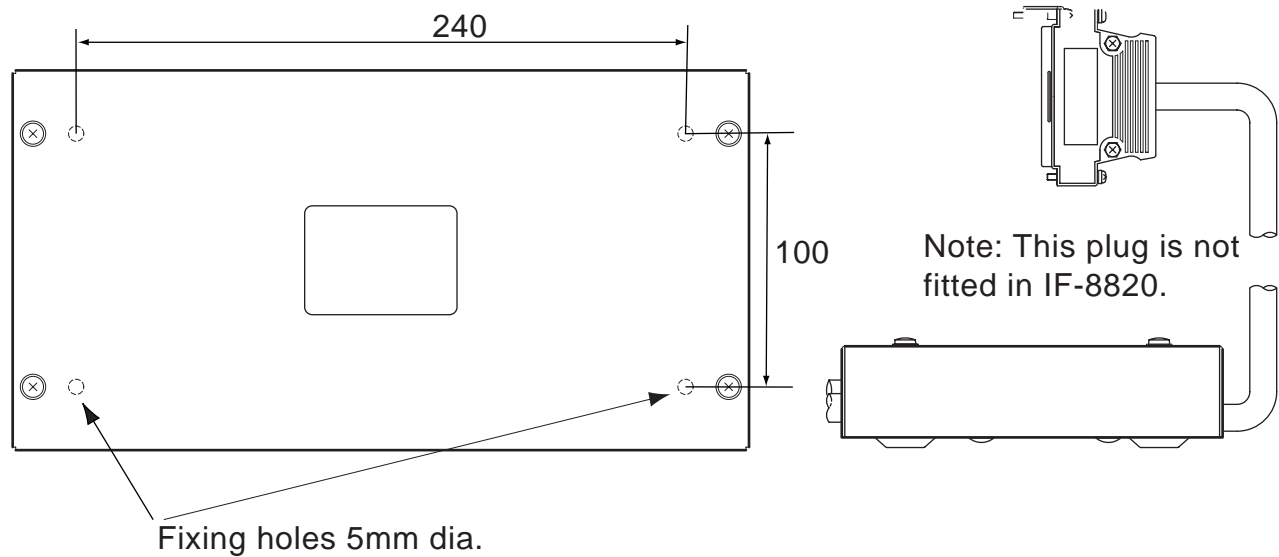

*Mounting the junction box/DMC interface*

## 1. MOUNTING

### Remote station RB-8800/RB-8810 (option)

Up to four remote stations can be connected in a daisy chain.

**Note:** For the remote station RB-8800, there are two method of cable entry: bottom-side entry and rear-side entry. For rear-side entry, make one or two holes of more than 12 mm diameter. For last station in the daisy chain, just one cable entry hole is needed.

1. Remove screws on the handset hanger (four for RB-8800, six for RB-8810).
2. Remove upper chassis of the hanger.
3. Mount the base of the hanger to a bulkhead with self-tapping screws 4x20 (four for RB-8800), or 4x16 (two for RB-8810).
4. After connecting cables, assemble the remote station.
5. For RB-8800, attach blind seals on the screws.

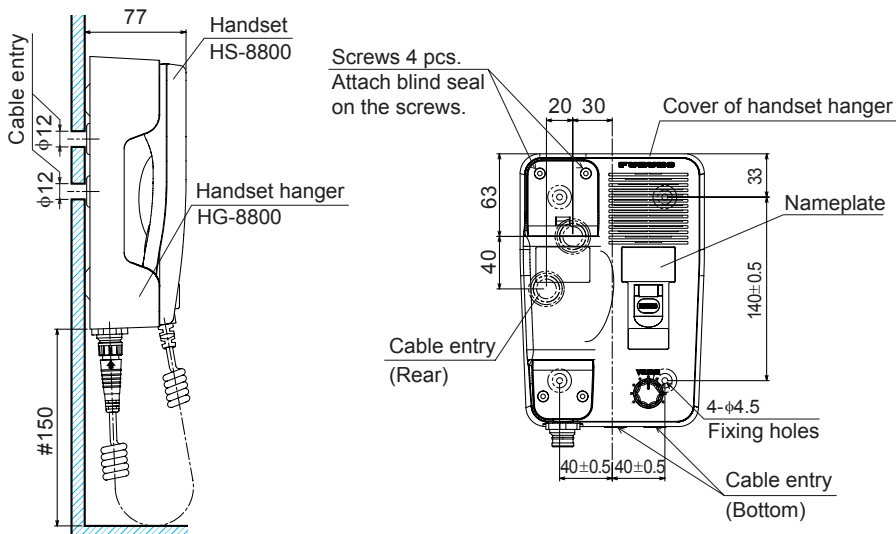

*Remote station RB-8800*

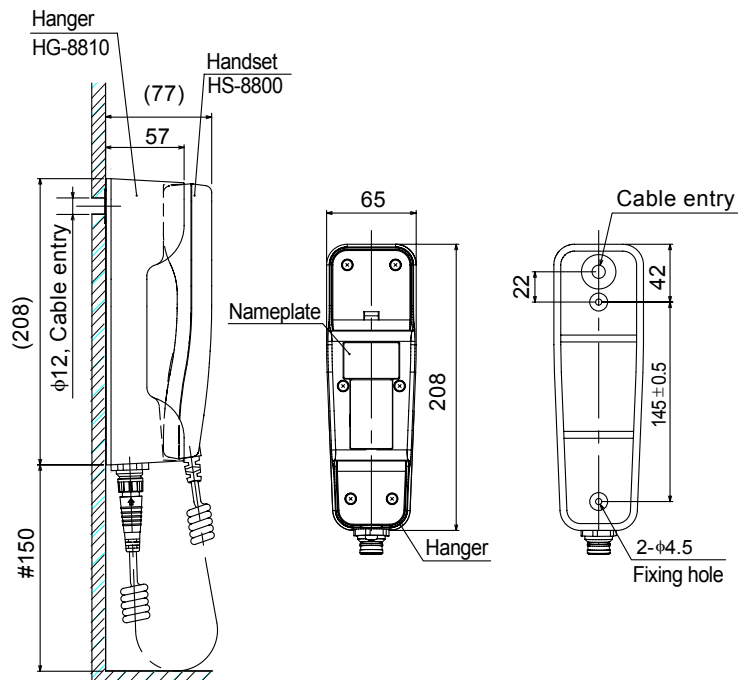

*Remote station RB-8810*



## 2. CONNECTIONS

### Overview

The figure below shows where to connect various equipment at the rear of the transceiver unit.

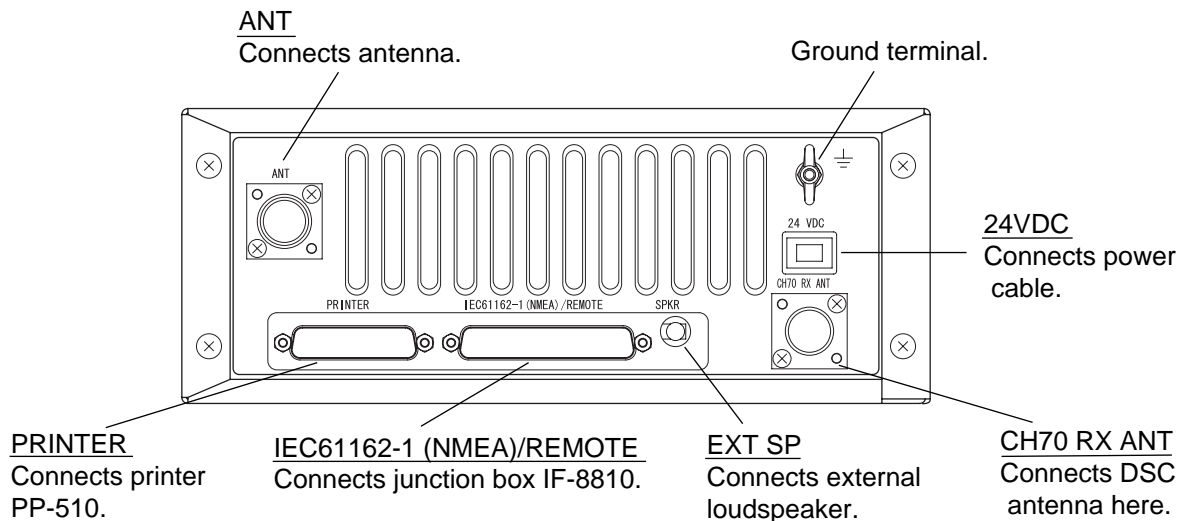

*FM-8800D/8800S, rear view*

### Connection of Power Supply

#### Convention vessels, 100/220 VAC ship's mains

Convention vessels must supply both AC and DC power to the FM-8800D/8800S, via an AC/DC power supply unit. Both AC and DC are supplied by the AC/DC power supply unit, and when AC input fails DC power is activated.

Connect the radio battery to the DC IN terminal on the PR-240-CE. Connect the AC ship's mains to the AC IN terminal on the PR-240-CE.

#### Radio battery (24 VDC)

Attach the connector supplied to the power cable and plug it into the 24VDC connector at the rear of the transceiver unit. Connect the wire ends to the radio battery line.

## Connection of VHF Antenna

The VHF antenna is connected to the transceiver unit with a 50 ohm coaxial cable, type 5D-2V. Be sure to leave some slack in the cable for future service and maintenance.

Lay the coaxial cable and attach an M-type plug to the cable (if necessary) as follows.

1. Remove the sheath by 20 mm.
2. Bare 13 mm of the center conductor. Trim braided shield by 5 mm and tin.
3. Slide coupling ring onto cable.
4. Screw the plug assembly on the cable.
5. Solder plug assembly to braided shield through solder holes. Solder contact sleeve to conductor.
6. Screw coupling ring into plug assembly.
7. Screw the plug into the ANT connector at the rear of the transceiver unit.

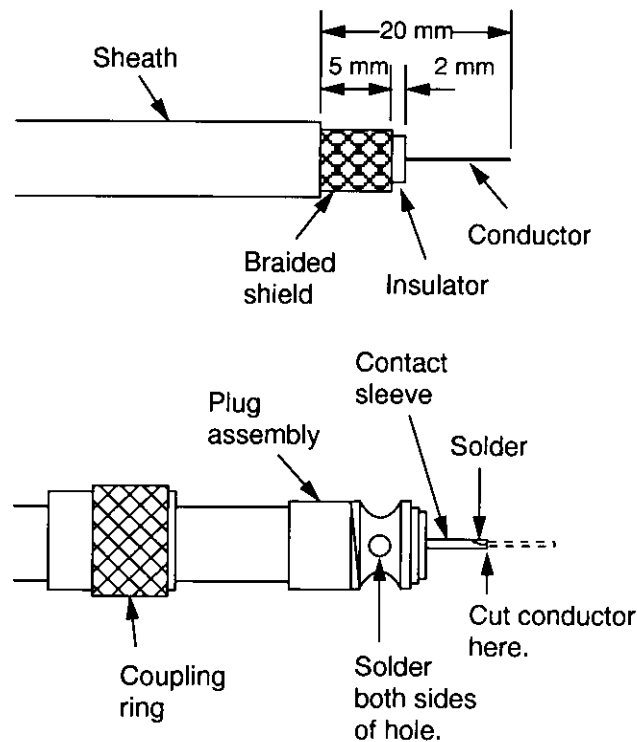

*How to attach the M-type plug to the coaxial cable*

## Connection of DSC Antenna

The DSC antenna is connected to the transceiver unit with a 50 ohm coaxial cable, type 5D-2V. Attach an M-type plug to the cable (if necessary) as shown on page 2-2. Screw the plug into the CH70 RX ANT connector at the rear of the transceiver unit.

## Connection of Handset

Connect the handset cable to the HANDSET connector on the front panel.

## Grounding the Transceiver Unit

Fasten a ground wire (local supply) between the GND terminal at the rear of the transceiver unit and ship's hull (or ground bus).

## Connecting the Junction Box

The junction box is required to connect a remote station, wing handset, etc. The cable to be connected with the transceiver unit is prefitted on the junction box at the factory. For connection of other cables, see the interconnection diagram.

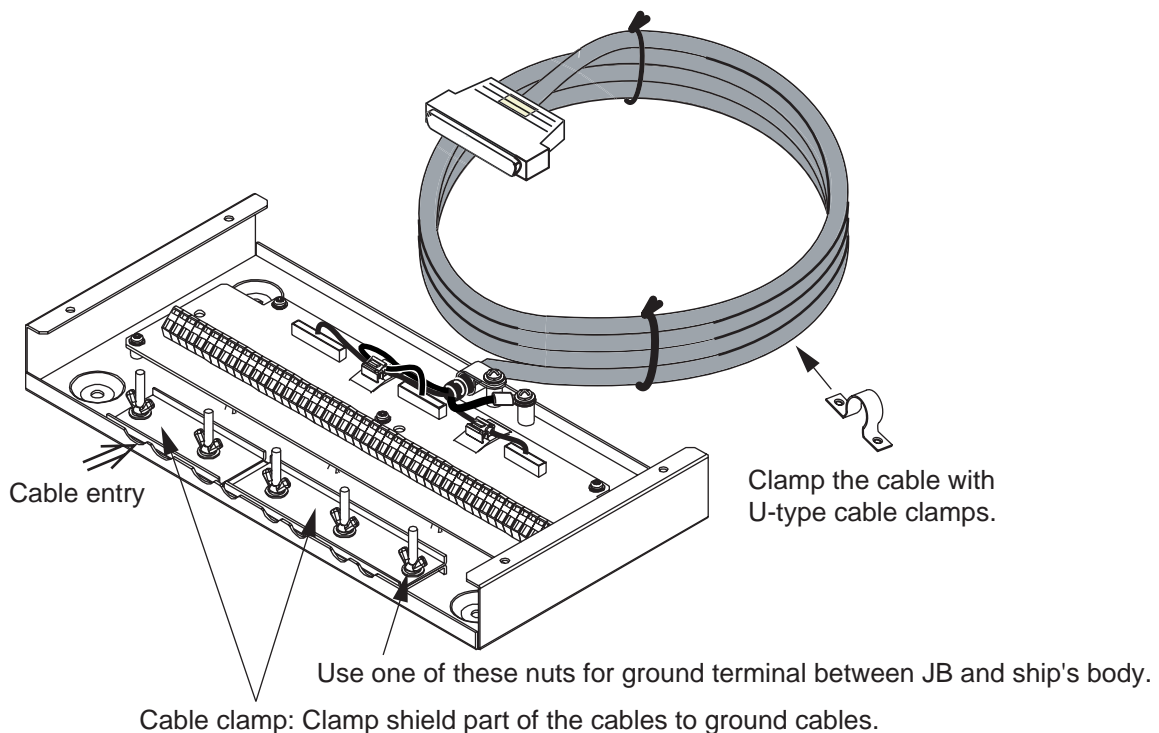

## Connecting the Remote Station without the Junction Box

The remote station (or DMC Interface, Mic. Receptacle box, etc) can be connected directly to the transceiver unit, using the D-sub connector supplied as installation materials. Attach the connector to the cable as follows.

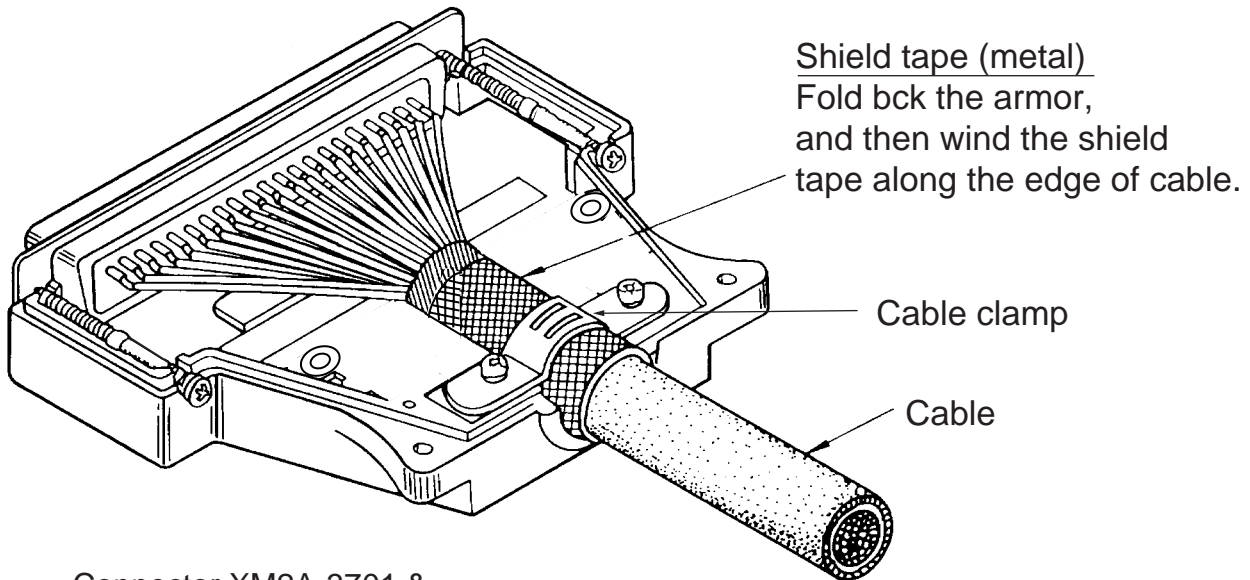

Connector XM2A-3701 &  
Housing case XM2S-3712

*Attachment of connector*

## When the handset HS-2003 is not connected to the Transceiver unit

The following modification is necessary.

1. Dismount the cover of the transceiver unit by removing four screws at the rear panel and two screws at the side.
2. Dismount the bottom cover by removing seven screws.

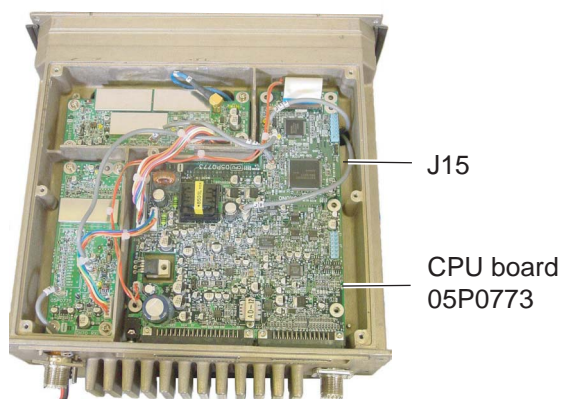

3. Shorten between #1 and #2 of J15.
4. Assemble the unit.

# Connection of AC/DC Power Supply Unit PR-240-CE

The power supply PR-240-CE is shipped ready for connection to a 200-230 VAC ship's mains. If the ship's mains is 100 VAC – 115 VAC, change the tap connection and terminal board connection as below. Attach label supplied as accessories to the punch mark in the front panel according to the ship's mains.

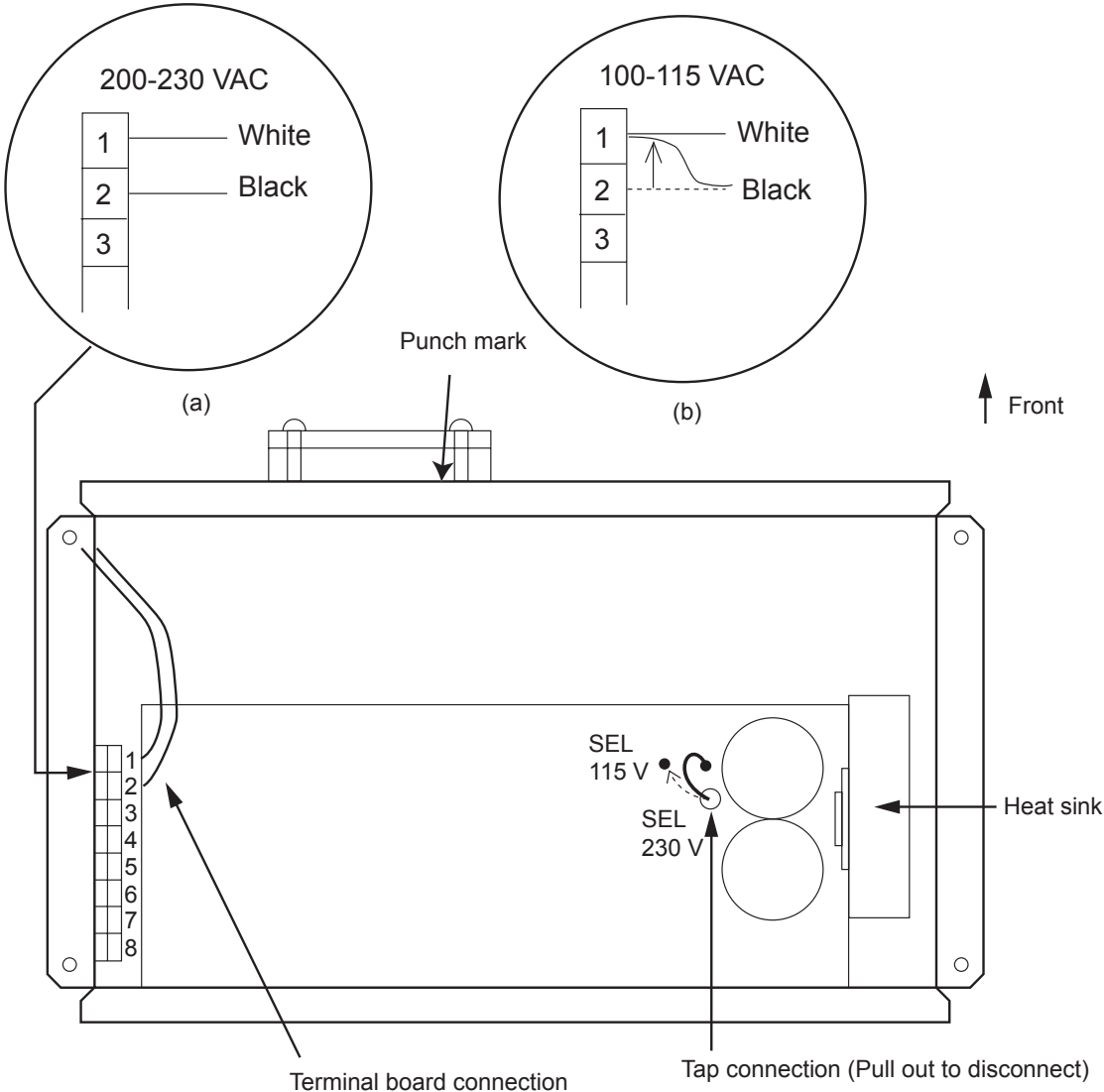

Ship's mains	Tap connection	Terminal board connection #1 & #2
100-115 VAC	SEL 115 V	b
200-230 VAC	SEL 230 V	a



Top view of AC/DC power supply unit (cover removed)

### Protective earth

Connect IV-2.0sq wire between ship's superstructure and the ground terminal on the PR-240-CE.

 <b>CAUTION</b>	
	<p><b>Attach protective earth securely to the ship's body.</b></p> <p>The protective earth (grounding) is required for the AC/DC power supply unit to prevent electrical shock.</p>

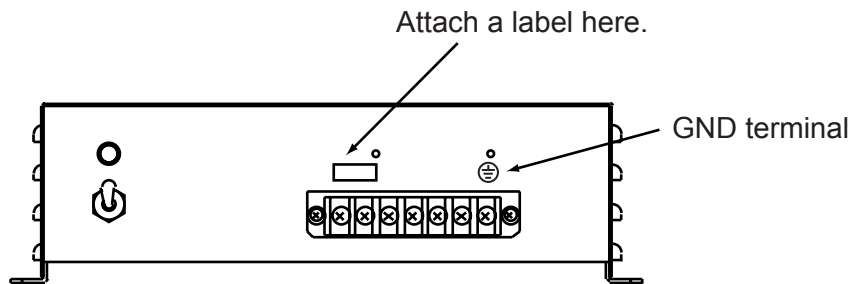

PR-240-CE Front panel

# Jumper Setting for Termination

It is necessary, for termination, to change the jumper setting for remote station or DMC interface.

Open the unit(s) terminated and change the jumper plugs J2 and J3 to ON position (#2-#3). (Default setting is OFF position.)

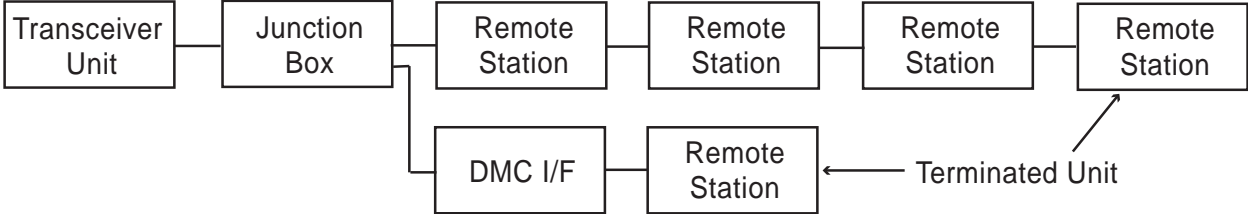

Note that up to four remote stations can be connected.

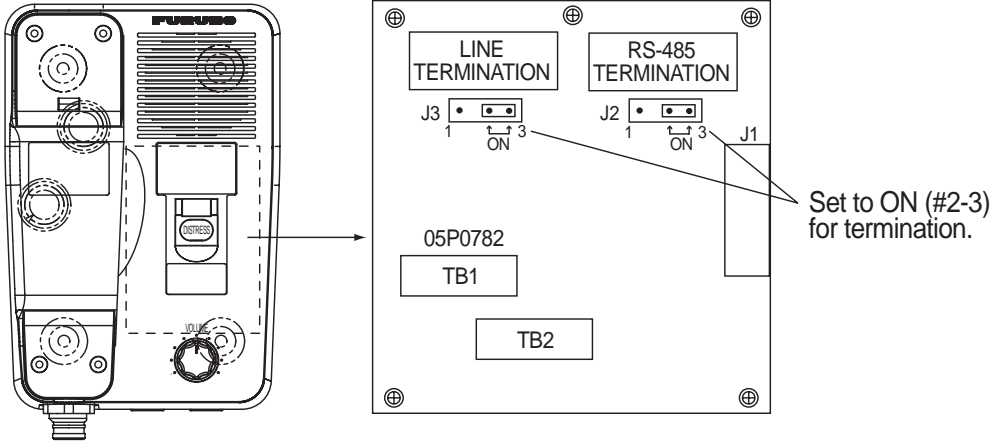

Remote station RB-8800

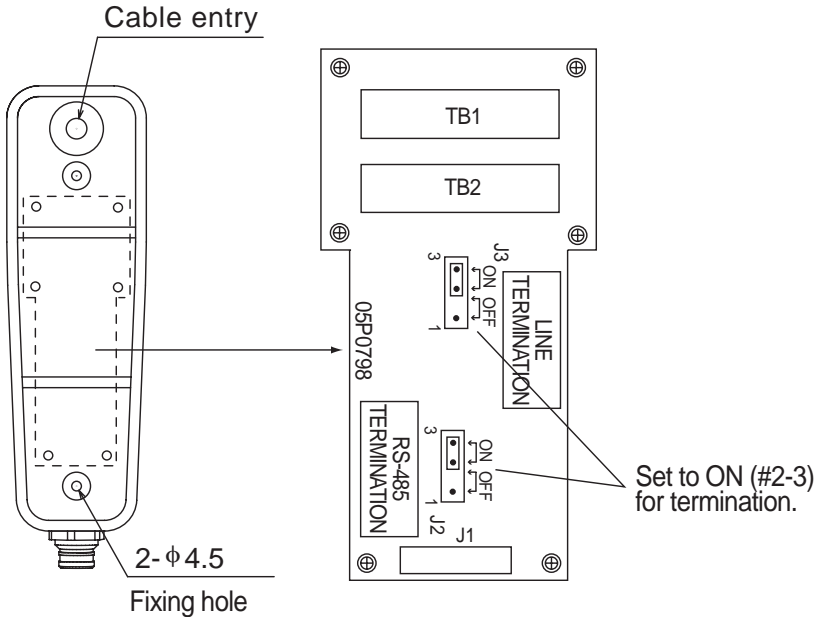

Remote station RB-8810

## 2. CONNECTIONS

Remove four screws  
to open the unit.

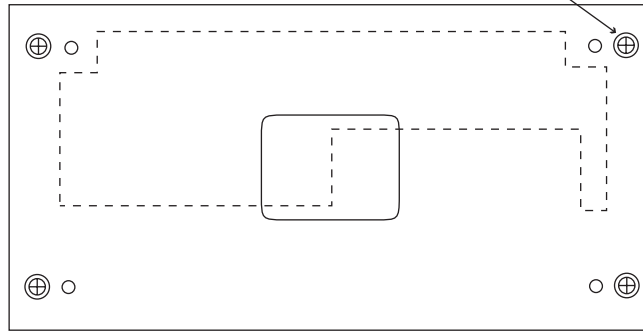

Set jumper plug to ON (#1-2).

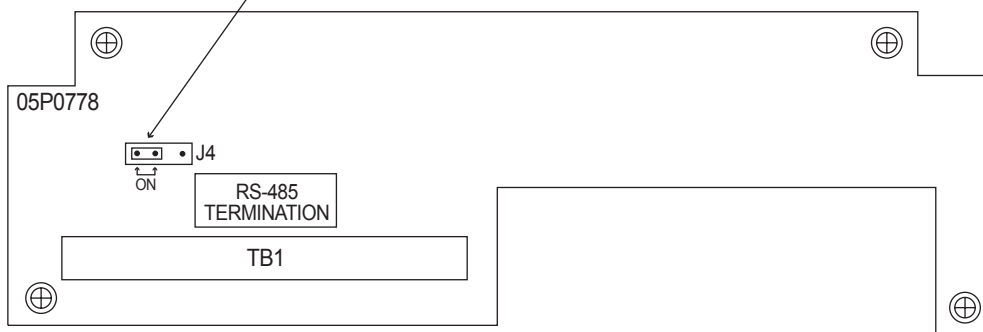

*DMC Interface IF-8820*







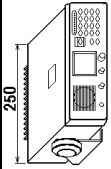

# PACKING LIST

FM-8800S-J/E-N/FM-8800D-J/E-N

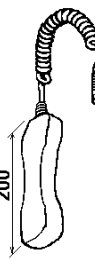
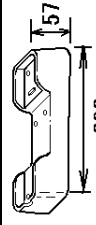
05EC-X-9851-3

1/1

NAME	OUTLINE	DESCRIPTION/CODE	Q'TY
<b>ユニット UNIT</b>			
送受信機 TRANSCIVER UNIT		FM-8800S/D	1
		000-054-225 **	
<b>予備品 SPARE PARTS</b>			
予備品 SPARE PARTS		SP05-05501	1
		005-377-820	
<b>付属品 ACCESSORIES</b>			
ハンドセット HANDSET		HS-2003	1
		000-054-223	
ハンドセット用組品 BRACKET FOR HANDSET		FP05-05510	1
		005-951-790	
付属品 ACCESSORIES		FP05-05511	1
		005-951-920	
<b>工事材料 INSTALLATION MATERIALS</b>			
ケーブル組品 CABLE ASSY.		05S9371-0	1
		000-151-711	

NAME	OUTLINE	DESCRIPTION/CODE	Q'TY
工事材料 INSTALLATION MATERIALS		CP05-09901	1
		005-377-800	

## 図書 DOCUMENT

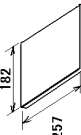
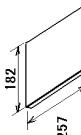
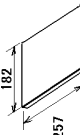
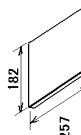
装備要領書 INSTALLATION MANUAL		IME-56420-*	1
		000-149-932 **	
取扱説明書 OPERATOR'S MANUAL		OME-56420-*	1
		000-149-930 **	
操作要領書 OPERATOR'S GUIDE		OSE-56420-*	1
		000-149-934 **	
遭難通信要領書 DISTRESS PROCEDURE		TIC-56420-*	1
		000-149-935	

コード番号末尾の「\*\*」は、選用品の代表型式/コードを表します。  
CODE NUMBER ENDING WITH "\*\*" INDICATES THE CODE NUMBER OF REPRESENTATIVE MATERIAL.





(略図の寸法は、参考値です。 DIMENSIONS IN DRAWING FOR REFERENCE ONLY. )

# PACKING LIST

FM-8800S-J/E-A/FM-8800D-J/E-A

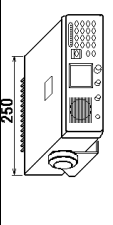
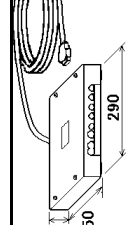
05EC-X-9856-1

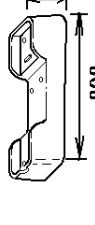
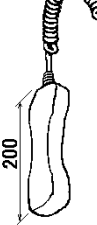
1/1

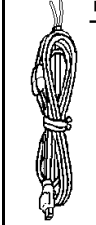

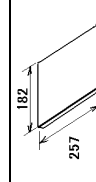
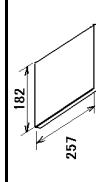
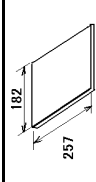
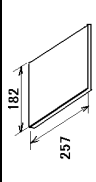

NAME	UNIT	OUTLINE	DESCRIPTION/CODE	Q'TY
ユニット				
送受信機			FM-8800S/D	1
送受信機			000-054-225 **	
ケーブルコネクタ			IF-8810	1
送受信機			000-054-219	
予備品				
予備品			SP05-05501	1
予備品			005-377-820	
付属品				
付属品			FP05-05511	1
付属品			005-951-920	
ハンドセット用ブラケット			FP05-05510	1
ハンドセット			005-951-790	1
ハンドセット			HS-2003	
ハンドセット			000-054-223	
工事材料				
工事材料			CP05-09901	1
工事材料			005-377-800	
ケーブル組品			05S9371-0	1
ケーブル組品			000-151-711	

1.コード番号末尾の["\*\*"]は、選択品の代表型式/コードを表します。  
CODE NUMBER ENDING WITH "\*\*\*" INDICATES THE CODE NUMBER OF REPRESENTATIVE MATERIAL.

NAME	OUTLINE	DESCRIPTION/CODE	Q'TY
工事材料			
工事材料		CP05-08701	1
工事材料		005-949-280	
図書			
遭難通信要領書		TIC-56420-*	1
遭難通信要領書		000-149-935 **	
操作要領書		OSE-56420-*	1
操作要領書		000-149-934 **	
取扱説明書		OME-56420-*	1
取扱説明書		000-149-930 **	
装備要領書		IME-56420-*	1
装備要領書		000-149-932 **	

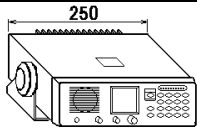
**PACKING LIST**

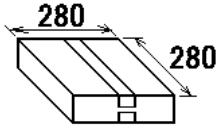
FM-8800S-F-N/FM-8800D-F-N

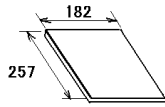
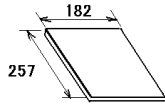
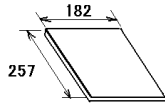
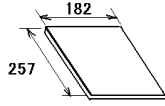
NAME	OUTLINE	DESCRIPTION/CODE	Q'TY
<b>UNIT</b>			
TRANSCEIVER UNIT		FM-8800S/D	1
		000-054-225 **	
<b>SPARE PARTS</b>			
SPARE PARTS		SP05-05501	1
		005-377-820	
<b>ACCESSORIES</b>		<b>FP05-05710</b>	
MICROPHONE		DM-2003-F	1
		005-377-760	
<b>INSTALLATION MATERIALS</b>		<b>CP05-09900</b>	
INSTALLATION MATERIALS		CP05-09901	1
		005-377-800	
CABLE ASSY.		05S9371-0	1
		000-151-711	
<b>DOCUMENT</b>			
DISTRESS PROCEDURE		TIC-56420-*	1
		000-149-935	
OPERATOR'S GUIDE		OSE-56420-*	1
		000-149-934	
INSTALLATION MANUAL		IME-56420-*	1
		000-149-932	
OPERATOR'S MANUAL		OME-56420-*	1
		000-149-930	







CODE NUMBER ENDING WITH "\*" INDICATES THE CODE NUMBER OF REPRESENTATIVE MATERIAL.

DIMENSIONS IN DRAWING FOR REFERENCE ONLY.

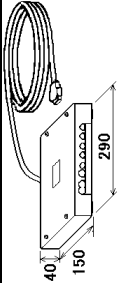
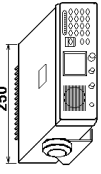
# P A C K I N G L I S T

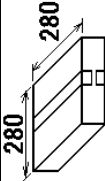
FM-8800S-F-A/FM-8800D-F-A

05EC-X-9859-0 1/1

NAME	OUTLINE	DESCRIPTION/CODE	Q'TY
<b>UNIT</b>			
JUNCTION BOX		IF-8810	1
		000-054-219	
TRANSMITTER UNIT		FM-8800S/D	1
		000-054-225 **	
<b>SPARE PARTS</b>			
SPARE PARTS		SP05-05501	1
		005-377-820	
<b>ACCESSORIES</b>			
MICROPHONE		DM-2003-F	1
		005-377-760	
<b>INSTALLATION MATERIALS</b>			
CABLE ASSY.		05S9371-0	1
		000-151-711	
INSTALLATION MATERIALS		CP05-09901	1
		005-377-800	
<b>INSTALLATION MATERIALS</b>			
INSTALLATION MATERIALS		CP05-08701	1
		005-949-280	

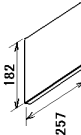
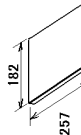
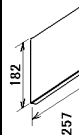
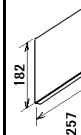
NAME	OUTLINE	DESCRIPTION/CODE	Q'TY
<b>DOCUMENT</b>			
INSTALLATION MANUAL		IME-56420-*	1
		000-149-932	
OPERATOR'S MANUAL		OME-56420-*	1
		000-149-930	
OPERATOR'S GUIDE		OSE-56420-*	1
		000-149-934	
DISTRESS PROCEDURE		TIC-56420-*	1
		000-149-935	

CODE NUMBER ENDING WITH "\*\*\*\*" INDICATES THE CODE NUMBER OF REPRESENTATIVE MATERIAL.

(DIMENSIONS IN DRAWING FOR REFERENCE ONLY.)

# PACKING LIST

05EC-X-9857 -0 1/1 A-5

DM-2003-F

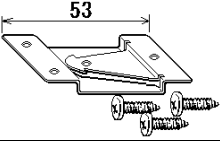
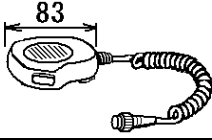
NAME	OUTLINE	DESCRIPTION/CODE	Q'TY
マイクセット MICROPHONE SET			
フック HOOK		ZIRXXCDM002 000-150-017	1
マイクロフォン MICROPHONE		DM-2003-F 000-150-016	1

(略図の寸法は、参考値です。 DIMENSIONS IN DRAWING FOR REFERENCE ONLY.)

05EC-X-9857

**FURUNO**

CODE NO.	005-377-800	05EC-X-9401 -2 1/1
TYPE	CP05-09901	

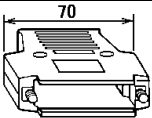
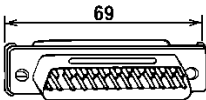
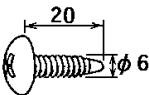
工事材料表 INSTALLATION MATERIALS					
番号 NO.	名称 NAME	略図 OUTLINE	型名 / 規格 DESCRIPTIONS	数量 Q'TY	用途 / 備考 REMARKS
1	ミニコン組品 (1) CABLE ASSY.		L-420	1	
			CODE NO.		
2	コネクタマウント (XM2) HOUSING CASE		XM2S-3712	1	
			CODE NO.		
3	コネクタ (XM2) CONNECTOR		XM2A-3701	1	
			CODE NO.		
4	+トラスタップ 1種 SELF-TAPPING SCREW		6X20 SUS304	5	
			CODE NO.		

05EC-X-9401

FURUNO ELECTRIC CO., LTD.  
(略図の寸法は、参考値です。 DIMENSIONS IN DRAWING FOR REFERENCE ONLY.)

**FURUNO**

CODE NO.	005-949-280	05DY-X-9417 -0 1/1
TYPE	CP05-08701	



工事材料表 INSTALLATION MATERIALS					
番号 NO.	名称 NAME	略図 OUTLINE	型名/規格 DESCRIPTIONS	数量 Q'TY	用途/備考 REMARKS
1	+トラスタップ°ネジ 1種 SELF-TAPPING SCREW		5X20 SUS304 CODE NO. 000-802-081	4	

05DY-X-9417

FURUNO ELECTRIC CO., LTD.  
 (略図の寸法は、参考値です。 DIMENSIONS IN DRAWING FOR REFERENCE ONLY.)

**FURUNO**

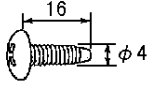
CODE NO.	005-951-920	05DZ-X-9502 -0 1/1
TYPE	FP05-05511	

付属品表 ACCESSORIES					
番号 NO.	名称 NAME	略図 OUTLINE	型名 / 規格 DESCRIPTIONS	数量 Q'TY	用途 / 備考 REMARKS
1	+トラスタップネジ SELF-TAPPING SCREW		4X16 SUS304 171	2	
			CODE NO.		
2	ホリカワッシャー WASHER		M4	2	
			CODE NO.		

05DZ-X-9502

FURUNO ELECTRIC CO., LTD.  
 (略図の寸法は、参考値です。 DIMENSIONS IN DRAWING FOR REFERENCE ONLY.)



**FURUNO**

CODE NO.	005-959-720	05EC-X-9502 -2 1/1
TYPE	FP05-05701	

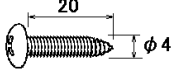
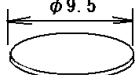
付属品表 ACCESSORIES		RB-8800			
番号 NO.	名称 NAME	略図 OUTLINE	型名 / 規格 DESCRIPTIONS	数量 Q'TY	用途 / 備考 REMARKS
1	ホリカワッシャー WASHER		M4	4	
			CODE NO.		
2	+トラスタップソネジ SELF-TAPPING SCREW		4X20 SUS304	4	
			CODE NO.		
3	ブライントシール SEAL		05-086-1102-2	4	
			CODE NO.		

05EC-X-9502

FURUNO ELECTRIC CO., LTD.  
 (略図の寸法は、参考値です。 DIMENSIONS IN DRAWING FOR REFERENCE ONLY.)

# FURUNO

CODE NO.	005-377-820	05EC-X-9301 -0 1/1
TYPE	SP05-05501	BOX NO. P

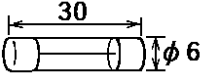
SHIP NO.		SPARE PARTS LIST FOR		U S E			SETS PER VESSEL
ITEM NO.	NAME OF PART	OUTLINE	DWG. NO. OR TYPE NO.	QUANTITY			REMARKS/CODE NO.
				WORKING		SPARE	
				PER SET	PER VES		
1	ヒューズ FUSE		FGBO 15A AC125V			2	000-549-014
MFR'S NAME	FURUNO ELECTRIC CO.,LTD.			DWG NO.	05EC-X-9301		1/1

(略図の寸法は、参考値です。 DIMENSIONS IN DRAWING FOR REFERENCE ONLY.)

表 1 TABLE 1

寸法区分 (mm) DIMENSIONS	公差 (mm) TOLERANCE
L ≤ 50	± 1.5
50 < L ≤ 100	± 2.5
100 < L ≤ 500	± 3

表 2 TABLE 2

機種名 MODEL	質量 (kg±10%) MASS
FM-8800S	5.5
FM-8800D	6.4

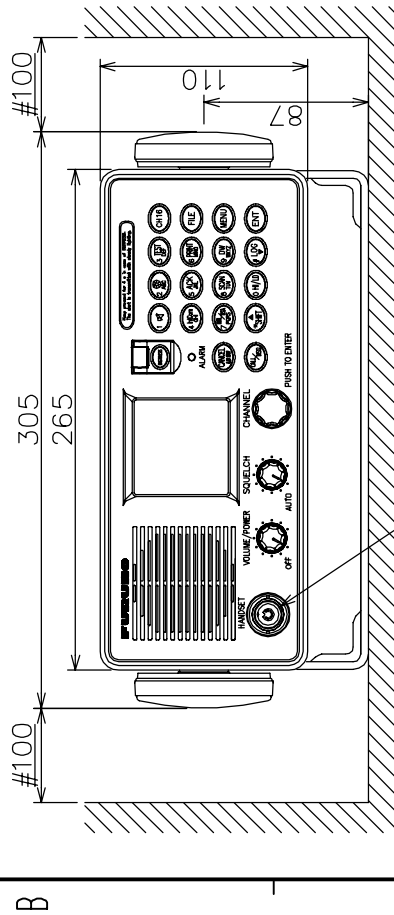
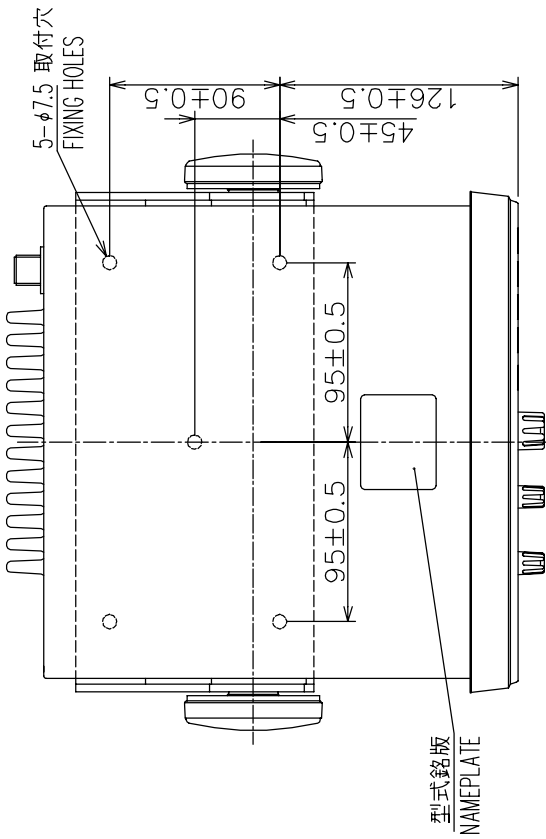
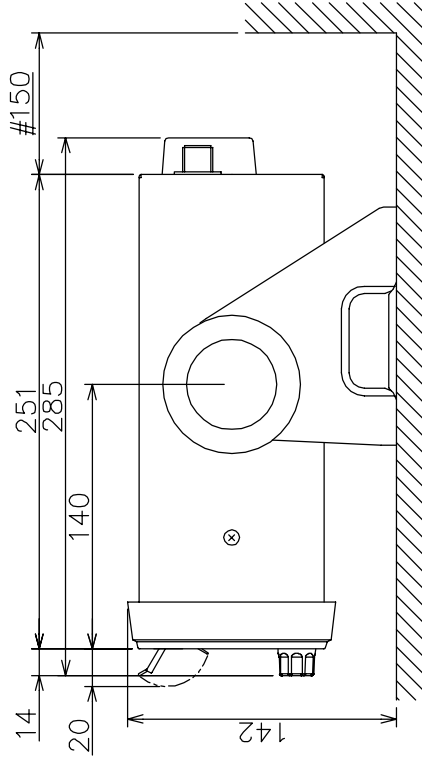
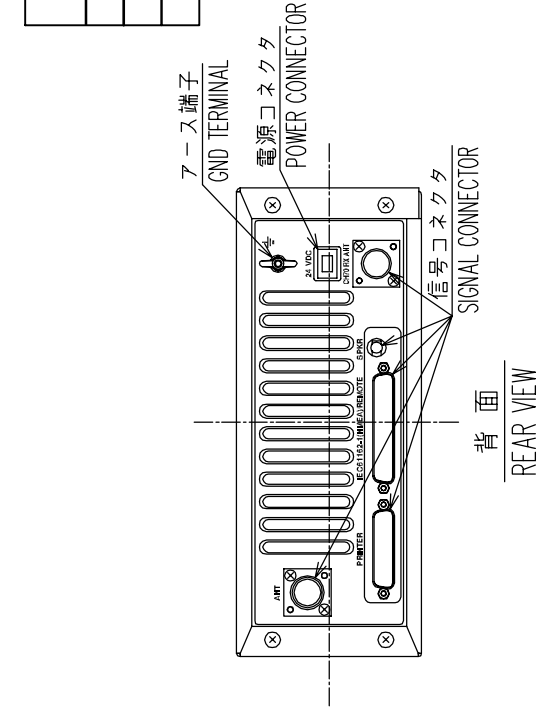

- 注 記 1) # 印寸法は最小サービスクリアランスとする。  
 2) 指定外の寸法公差は表 1 による。  
 3) 取付用ネジは + トラスタップピンネジ 6 × 2.0 を使用のこと。
- NOTE 1. # : MINIMUM SERVICE CLEARANCE.  
 2. TABLE 1 INDICATES TOLERANCE OF DIMENSIONS WHICH IS NOT SPECIFIED.  
 3. USE SELF-TAPPING SCREWS 6x2.0 FOR FIXING THE UNIT.

DRAWN	Sep. 22, '04 E. MIYOSHI	TITLE	FM-8800S/D
CHECKED	T. TAKAHASHI	名称	送受信機 (卓上装備)
APPROVED	Y. Hatai	外寸図	
SCALE	1/4 MASS 表 2 参照 TABLE 2	NAME	FM-8800S/D RECEIVER UNIT (TABLETOP MOUNT)
DWG. No.	C5642-G01-A		05-093-1006-4 OUTLINE DRAWING

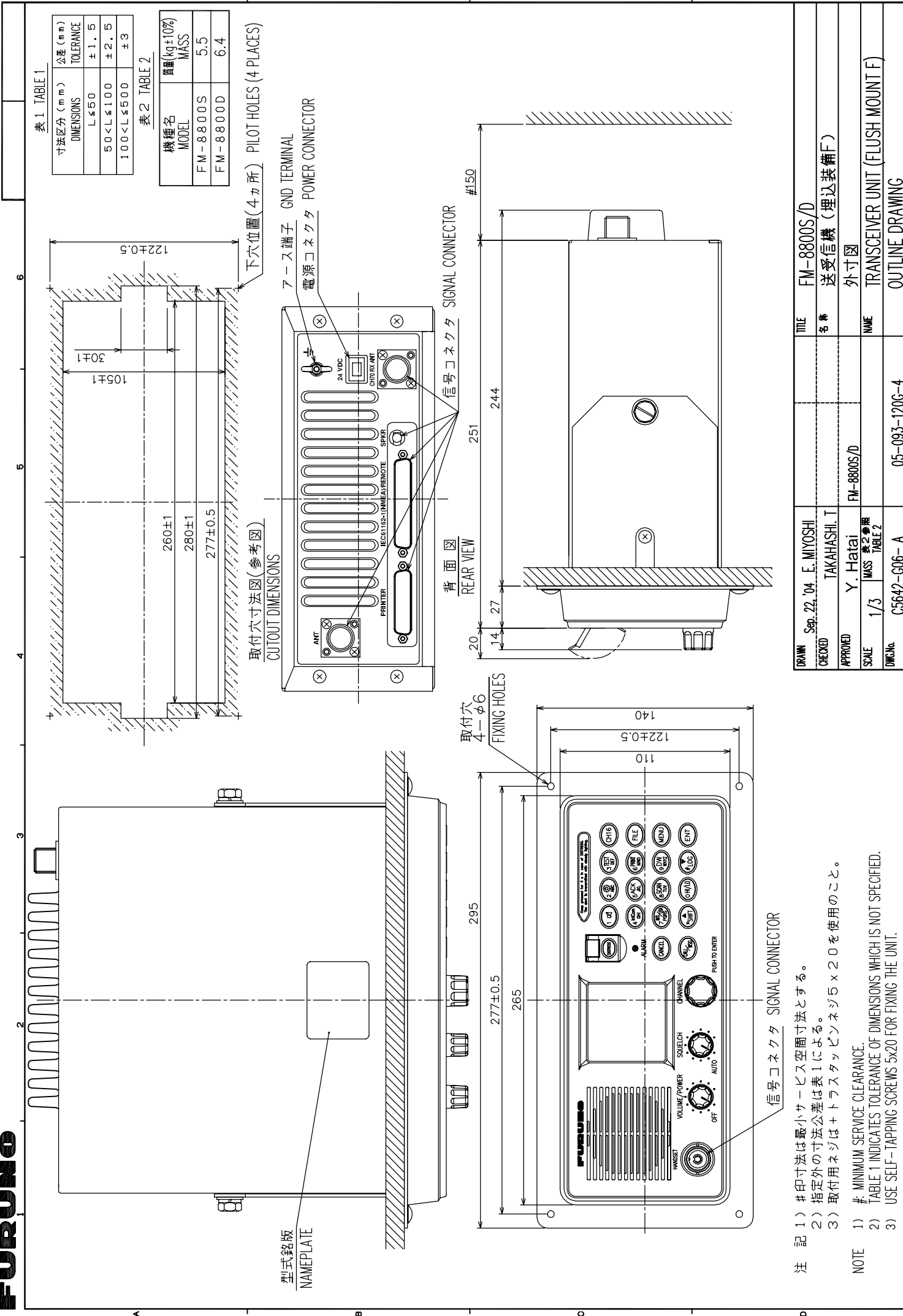

注記 1) #印寸法は最小サービス空間寸法とする。  
 2) 指定外の寸法公差は表1による。  
 3) 取付用ネジは+トラスタックピンネジ5x2.0を使用のこと。

NOTE 1) # MINIMUM SERVICE CLEARANCE.  
 2) TABLE 1 INDICATES TOLERANCE OF DIMENSIONS WHICH IS NOT SPECIFIED.  
 3) USE SELF-TAPPING SCREWS 5x2.0 FOR FIXING THE UNIT.

DRAWN	Sep. 22, '04	E. MIYOSHI	TITLE	FM-8800S/D
CHECKED		TAKAHASHI, T	名称	送受信機 (埋込装備)
APPROVED		Y. Hatai	外寸図	
SCALE	1/3	表2参照 TABLE 2	NAME	TRANSCIVER UNIT (FLUSH MOUNT F)
DWG. No.	C5642-G06-A	05-093-120G-4	OUTLINE DRAWING	

表 1 TABLE 1

寸法区分 (mm) DIMENSIONS	公差 (mm) TOLERANCE
$L \leq 50$	$\pm 1.5$
$50 < L \leq 100$	$\pm 2.5$
$100 < L \leq 500$	$\pm 3$

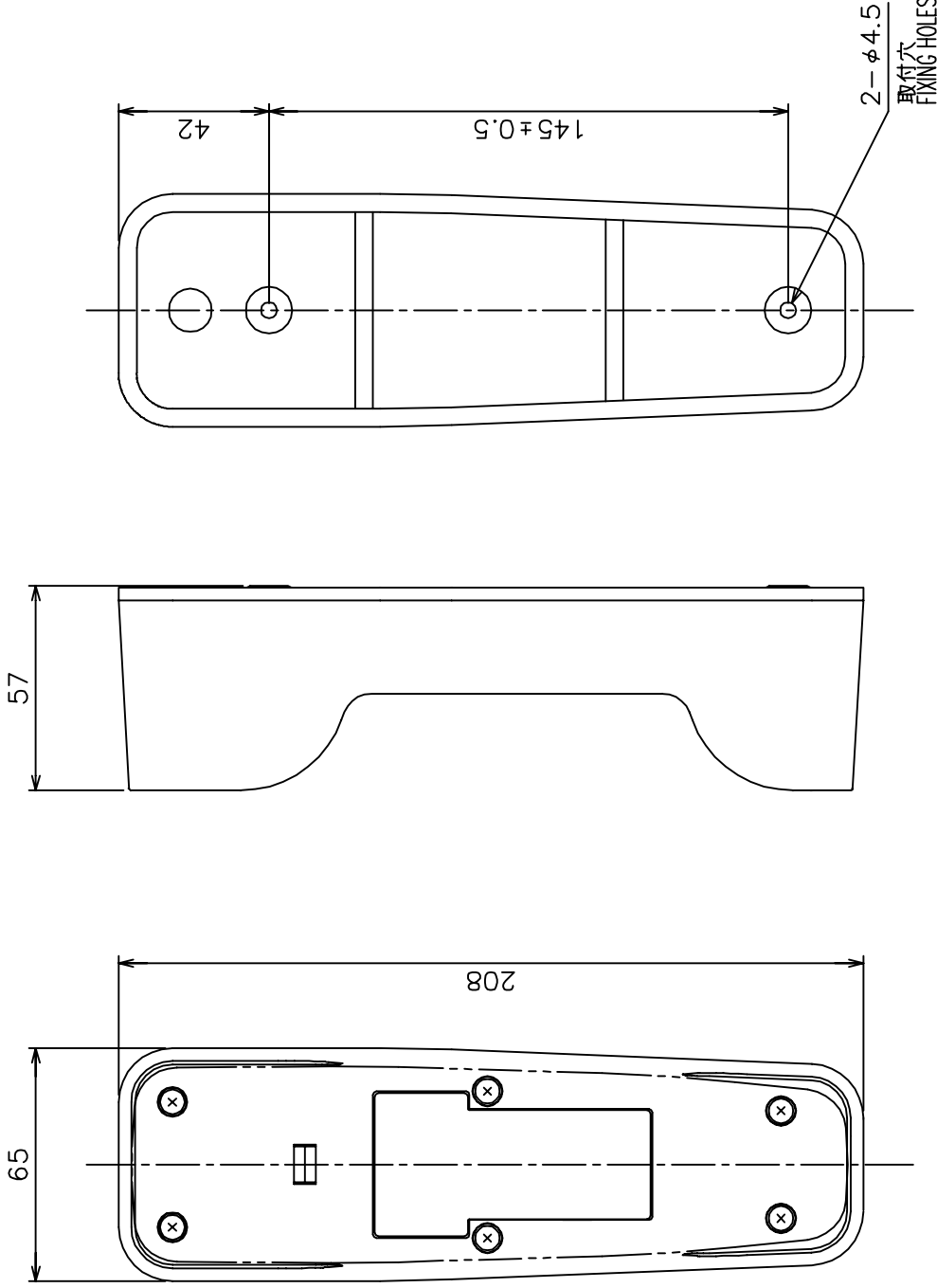

- 注 記 1) 指定外の寸法公差は表 1 による。  
 2) 取付用ネジは + トラスタップピンネジ 4 x 16 を使用のこと。
- NOTE 1. TABLE 1 INDICATES TOLERANCE OF DIMENSIONS WHICH IS NOT SPECIFIED.  
 2. USE SELF-TAPPING SCREWS 4x16 FOR FIXING THE UNIT.

DRAWN Dec. 10, '04	E. MIYOSHI	TITLE	FP05-05510
CHECKED	TAKAHASHI, T	名称	ハンドセットハンガー
APPROVED	Y. Hatai	外寸図	
SCALE	1/2	質量	0.30 kg
FIG. No.	C5636-608-B		05-089-401G-2
		NAME	HANDSET HANGER
			OUTLINE DRAWING



表 1 TABLE 1

寸法区分 (mm) DIMENSIONS	公差 (mm) TOLERANCE
$L \leq 50$	$\pm 1.5$
$50 < L \leq 100$	$\pm 2.5$
$100 < L \leq 500$	$\pm 3$

注 記 指定外の寸法公差は表 1 による。  
 NOTE TABLE 1 INDICATES TOLERANCE OF DIMENSIONS WHICH IS NOT SPECIFIED.

DRAWN Dec. 10 '04 E. MIYOSHI	TITLE HS-2003
CHECKED TAKAHASHI. T	名称 ハンドセット
APPROVED Y. Hatai	外寸図
SCALE 1/2 MASS 0.20 <sup>±10%</sup> kg	NAME HANDSET
DWG.No. C5642-G10-C	05-093-200G-2 OUTLINE DRAWING

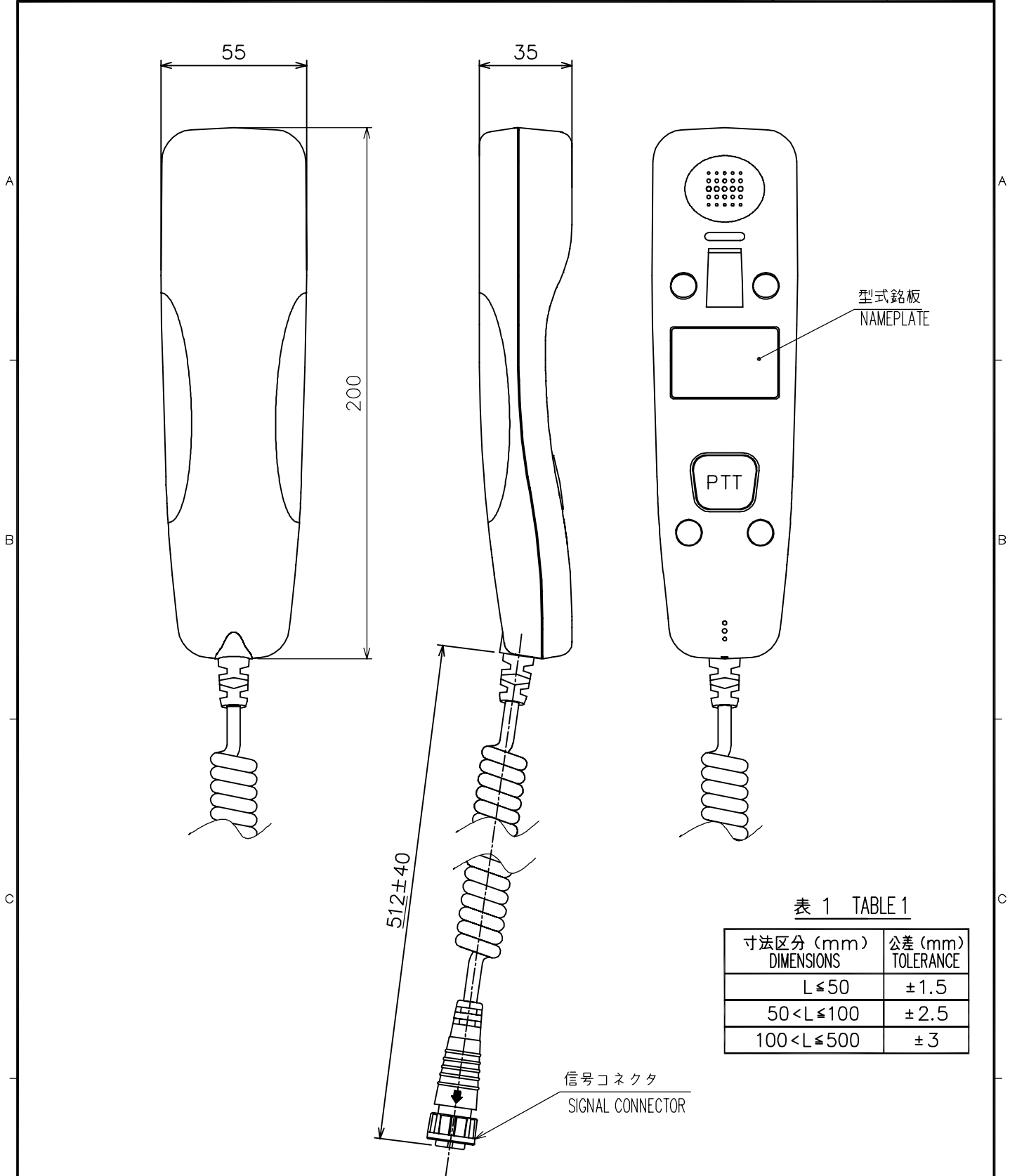
表 1 TABLE 1

寸法区分 (mm) DIMENSIONS	公差 (mm) TOLERANCE
$L \leq 50$	$\pm 1.5$
$50 < L \leq 100$	$\pm 2.5$
$100 < L \leq 500$	$\pm 3$

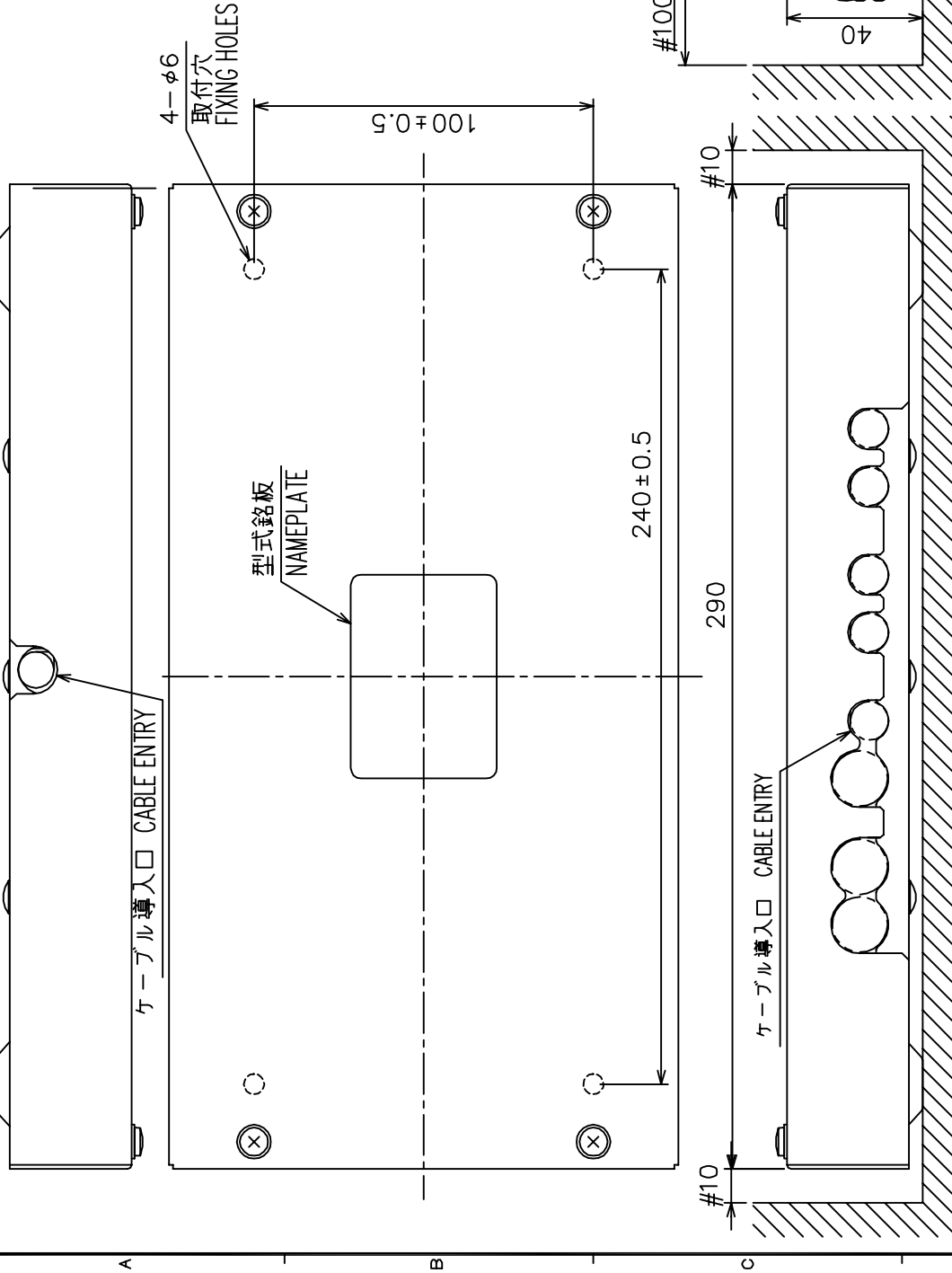

注 記 1) #印寸法は最小サービス空間寸法とする。  
 2) 指定外の寸法公差は表1による。  
 3) 取付用ネジは+トラスタップピンネジ呼び径5×20を使用のこと。

NOTE 1. # MINIMUM SERVICE CLEARANCE.  
 2. TABLE 1 INDICATES TOLERANCE OF DIMENSIONS WHICH IS NOT SPECIFIED.  
 3. USE SELF-TAPPING SCREWS 5x20 FOR FIXING THE UNIT.

DRAWN CHECKED	SEP. 3, '04 TAKAHASHI, T	EMIKYOSHI	TITLE 名 称	IF-8810 接続箱
APPROVED	Y. Hatai	FM-8800S/D	外寸図	
SCALE	1/2	1/20	NAME	JUNCTION BOX
DMC No.	C5642-603-C	05-093-400G-1		OUTLINE DRAWING

表 1 TABLE 1

寸法区分 (mm) DIMENSIONS	公差 (mm) TOLERANCE
L ≤ 50	± 1.5
50 < L ≤ 100	± 2.5
100 < L ≤ 500	± 3

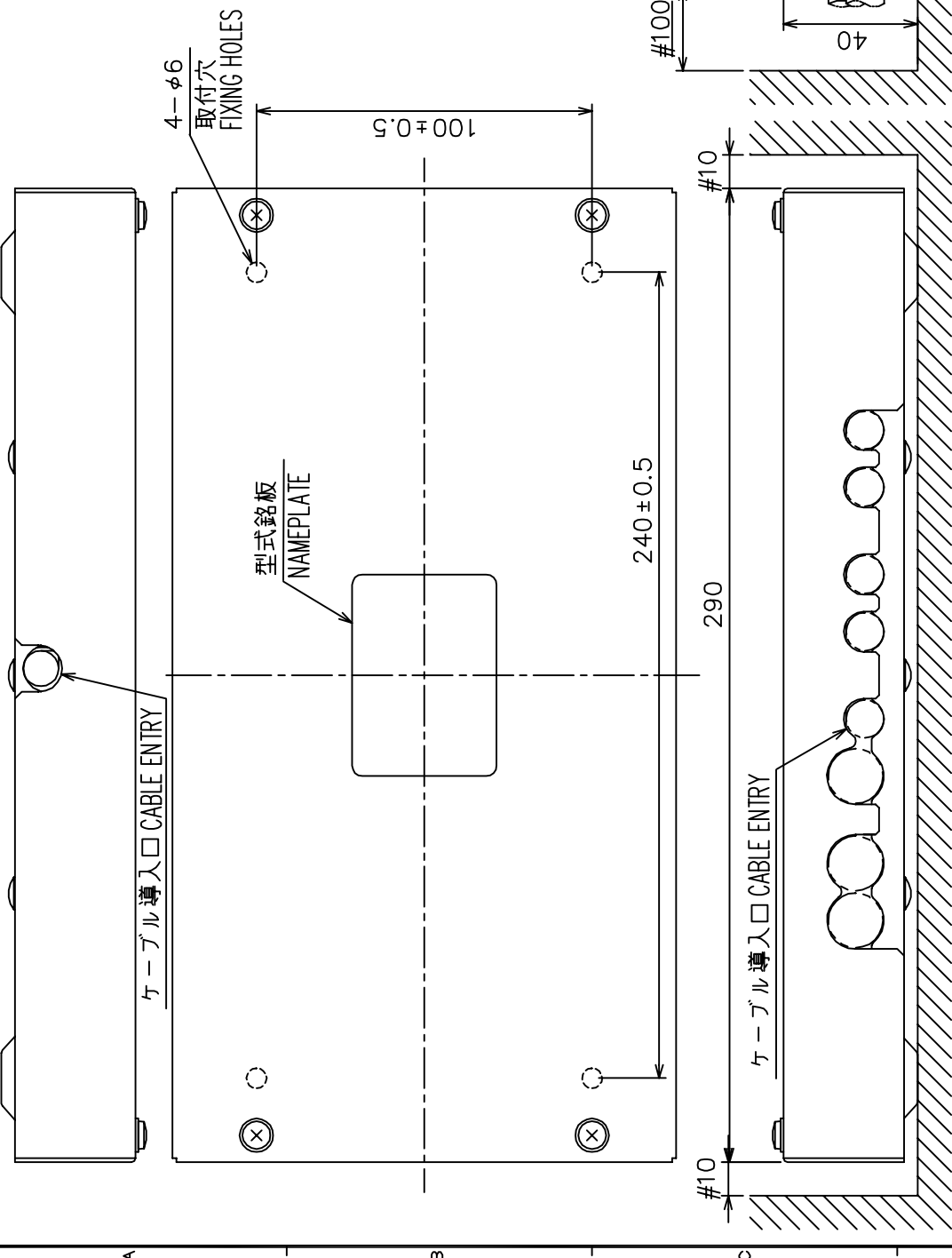

- 注 記 1) #印寸法は最小サービス空間寸法とする。  
 2) 指定外の寸法公差は表 1 による。  
 3) 取付用ネジは +トラスタップピンネジ呼び径 5 × 20 を使用のこと。
- NOTE 1. # MINIMUM SERVICE CLEARANCE.  
 2. TABLE 1 INDICATES TOLERANCE OF DIMENSIONS WHICH IS NOT SPECIFIED.  
 3. USE SELF-TAPPING SCREWS 5x20 FOR FIXING THE UNIT.

DRAWN	Sup. 22 '04	E. MIYOSHI	TITLE	IF-8820
CHECKED		TAKAHASHI, T	番号	DMCインターフェイス
APPROVED		Y. Hatai	外寸図	
SCALE	1/2	MASS 1.5	NAME	DMC INTERFACE UNIT
DMC No.	C5642-G04-C	05-093-5006-2		OUTLINE DRAWING





表 1 TABLE 1

寸法区分 (mm) DIMENSIONS	公差 (mm) TOLERANCE
L ≤ 50	±1.5
50 < L ≤ 100	±2.5
100 < L ≤ 500	±3

- 注 記 1) 指定外の寸法公差は表 1 による。  
 2) #印寸法は最小サービス空間寸法とする。  
 3) 取付用ネジは+トラスタップネジ呼び径4×20を使用のこと。
- NOTE 1. TABLE 1 INDICATES TOLERANCE OF DIMENSIONS WHICH IS NOT SPECIFIED.  
 2. #: MINIMUM SERVICE CLEARANCE.  
 3. USE SELF-TAPPING SCREWS 4x20 FOR FIXING THE UNIT.

DRAWN	Dec. 6, '04	E. MIYOSHI	TITLE	RB-8800
CHECKED		TAKAHASHI, T	名称	リモートステーション
APPROVED		Y. Hatai	FM-8800S/D	外寸図
SCALE	1/2	質量 1.1 ±10% kg	質量はハンドセット・ハンガーを含む。 MASS W/ HANDSET AND HANGER	NAME
DWG.No.	C5642-G02-A	05-093-300G-3		REMOTE STATION
				OUTLINE DRAWING

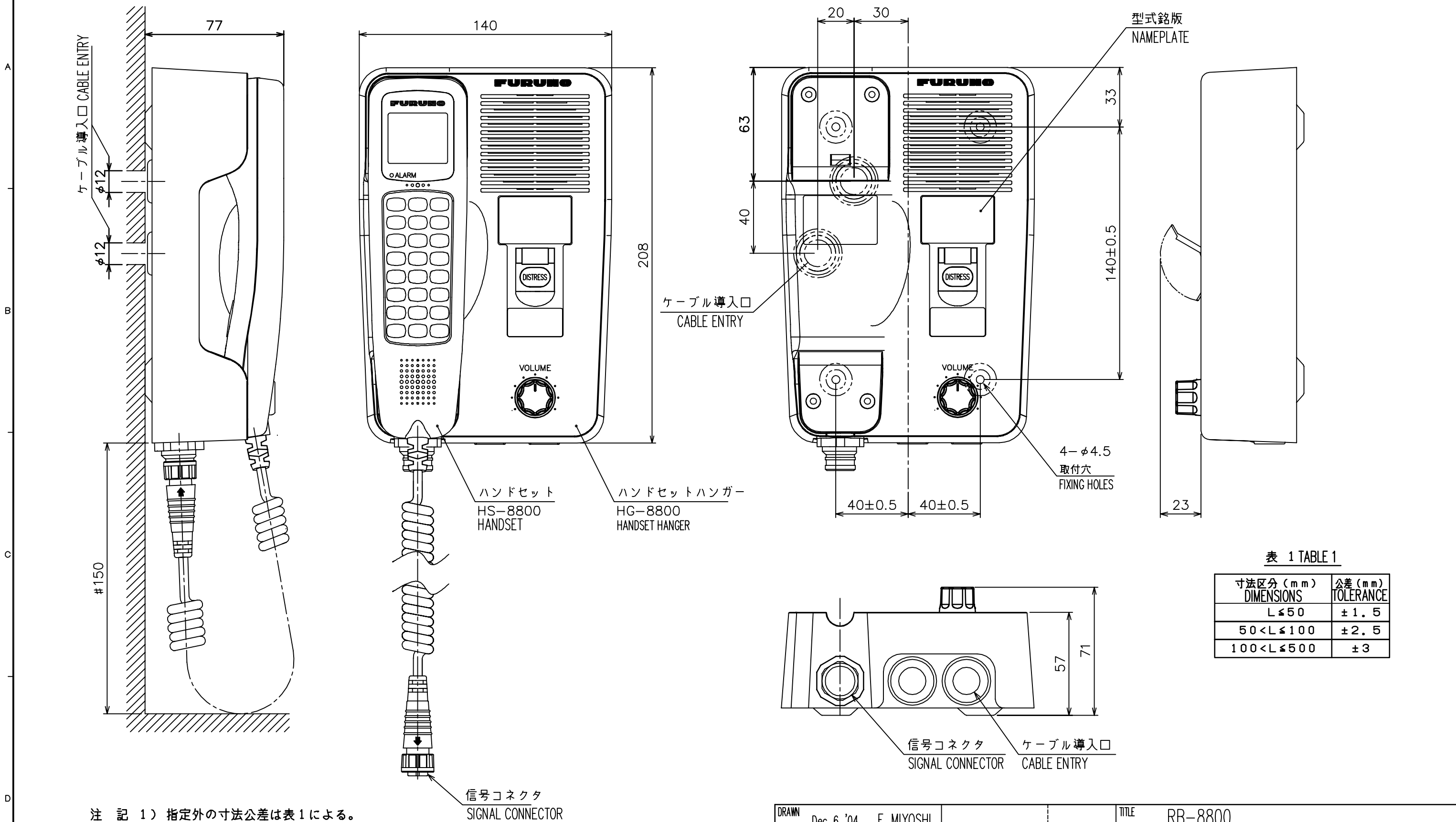
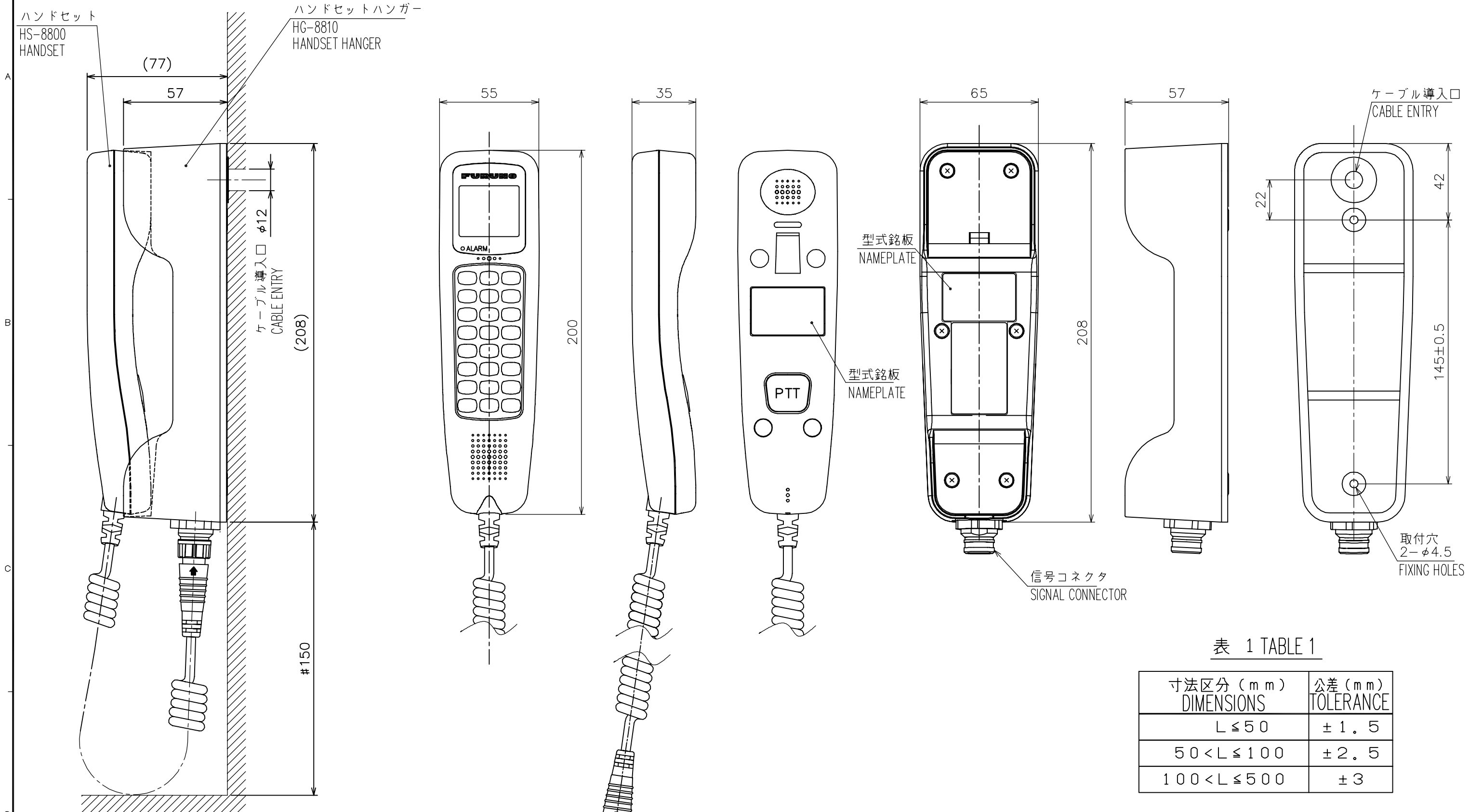

注 記 1) 指定外の寸法公差は表 1 による。  
 2) #印寸法は最小サービス空間寸法とする。  
 3) 取付用ネジは+トラスタップピンネジ呼び径4×16を使用のこと。

NOTE 1. TABLE 1 INDICATES TOLERANCE OF DIMENSIONS WHICH IS NOT SPECIFIED.  
 2. #: MINIMUM SERVICE CLEARANCE.  
 3. USE SELF-TAPPING SCREWS 4x16 FOR FIXING THE UNIT.

表 1 TABLE 1

寸法区分 (mm) DIMENSIONS	公差 (mm) TOLERANCE
L ≤ 50	± 1.5
50 < L ≤ 100	± 2.5
100 < L ≤ 500	± 3

DRAWN	Dec. 10, '04 E. MIYOSHI	TITLE	RB-8810
CHECKED	TAKAHASHI, T	名称	リモートステーション
APPROVED	Y. Hatai		外寸図
SCALE	1/2	FM-8800S/D	NAME
MASS	0.7 ±10% kg	質量はハンドセット・ハンガーを含む。 MASS W/ HANDSET AND HANGER	REMOTE STATION
DWG.No.	C5642-G09-A	05-093-310G-2	OUTLINE DRAWING

表 1 TABLE 1

寸法区分 (mm) DIMENSION	公差 (mm) TOLERANCE
L ≤ 50	± 1.5
50 < L ≤ 100	± 2.5
100 < L ≤ 500	± 3

4-φ6 取付穴  
FIXING HOLES

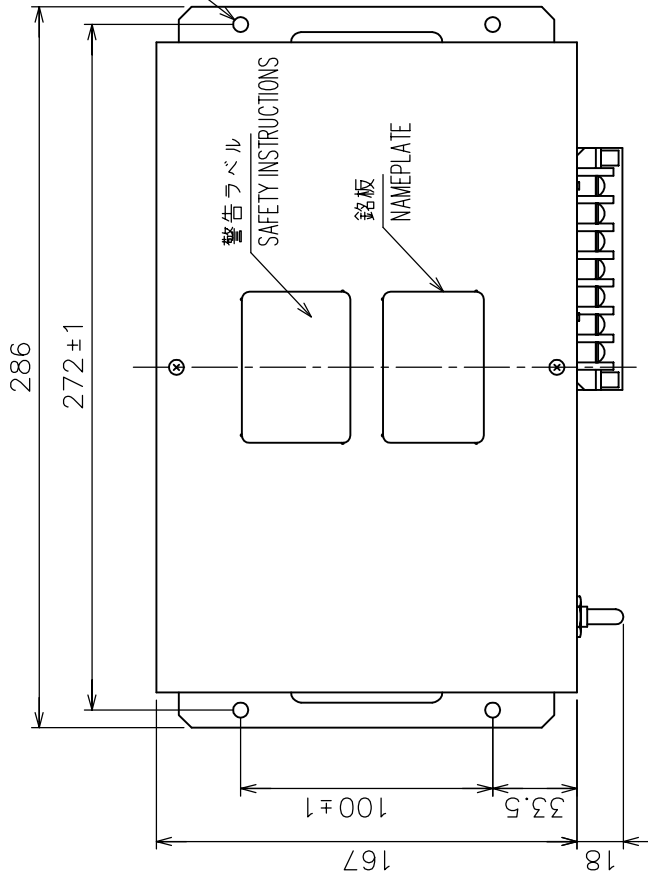

100-115 VACの時 200-230 VACの時

100-115 VAC 2.3-2.0A  
1φ 50/60Hz

200-230 VAC 1.15-1.0A  
1φ 50/60Hz

電源貼りマーク (尺度 1:1)  
POWER LABEL (SCALE 1:1)

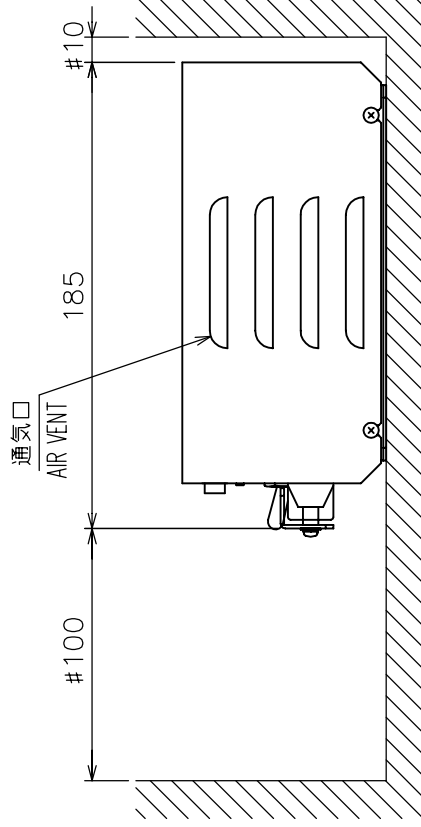
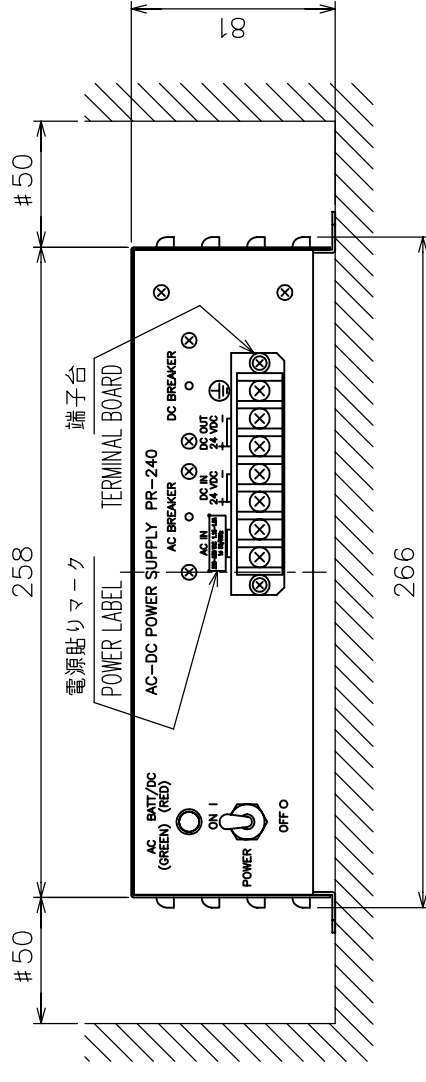

- 注 記 1) 指定なき寸法公差は表 1 による。  
 2) #印寸法は推奨する最小サービスクリアランスとする。  
 3) 取付用ネジはプラスタツピンネジ 呼び径 4 x 1.6 を使用のこと。
- NOTE 1. TABLE 1 INDICATES TOLERANCE OF DIMENSIONS WHICH IS NOT SPECIFIED.  
 2. # MINIMUM SERVICE CLEARANCE.  
 3. USE TAPPING SCREWS 4x1.6 FOR FIXING THE UNIT.

DRAWN	Mar. 3 '04	T. YAMASAKI	TITLE	PR-240-CF
CHECKED	Mar. 3 '04	T. TAKENO	名称	AC/DC 電源ユニット
APPROVED	Mar. 11 '04	H. Hayashi	外寸図	
SCALE	1/3	MAS 2.8	NAME	AC/DC POWER SUPPLY UNIT
DWG No.	CS003-G03-F			OUTLINE DRAWING
	24-003-500G-3			

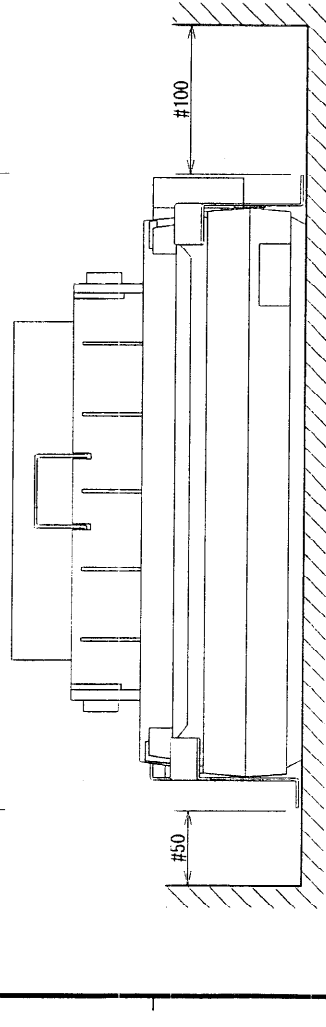
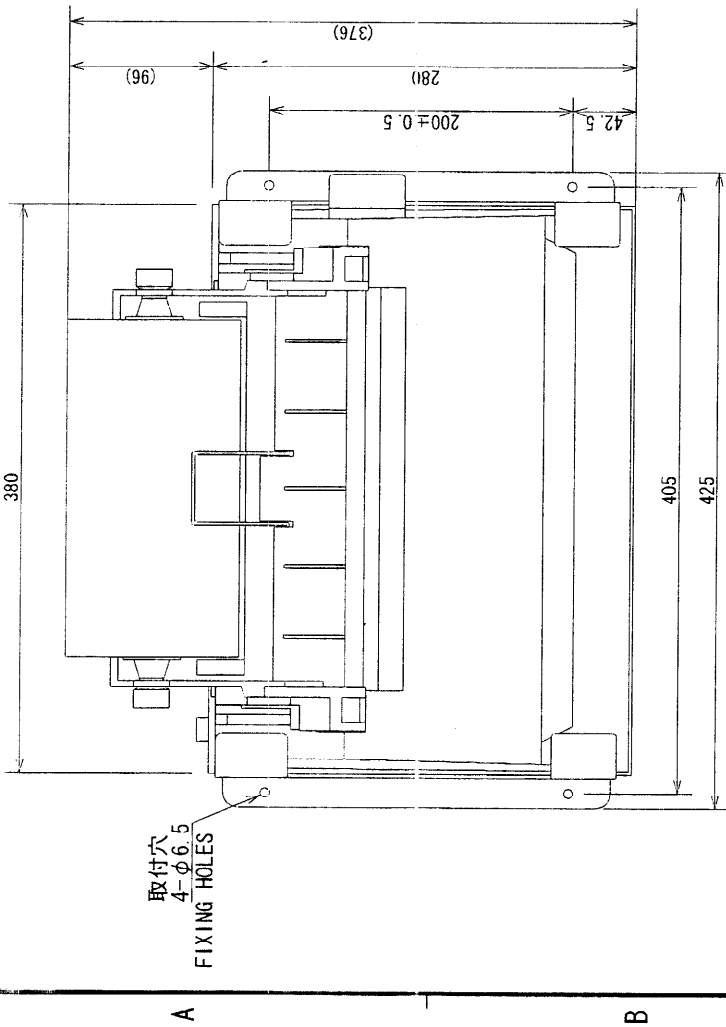

寸法区分 (mm) DIMENSION	公差 (mm) TOLERANCE
0 < L ≤ 50	± 1.5
50 < L ≤ 100	± 2.5
100 < L ≤ 500	± 3

表 1  
TABLE 1

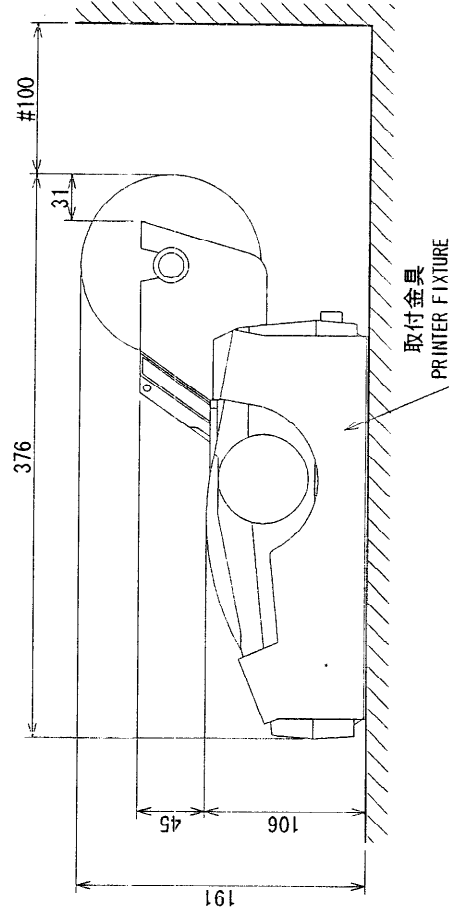

- 注 記
- 1) 印寸法は最小サービス空間寸法とする。
  - 2) 指定外の寸法公差は表 1 による。
  - 3) 取付用ネジは M6 ボルトまたはコーチボルト呼び径 6 を使用のこと。
- NOTE
1. #: RECOMMENDED SERVICE CLEARANCE.
  2. TABLE 1 INDICATES TOLERANCE OF DIMENSIONS.
  3. USE M6 BOLTS OR COACH BOLTS φ6 FOR FIXING UNIT.

DRAWING	PP-510	TITLE	PP-510
CHEKED	プリンタ	名称	プリンタ
APPROVED	外寸図	NAME	PRINTER
SCALE	1/5	16-007-660G-2	OUTLINE DRAWING
MASS	3.8 kg		
DWG. No.	C5589-G08-H		

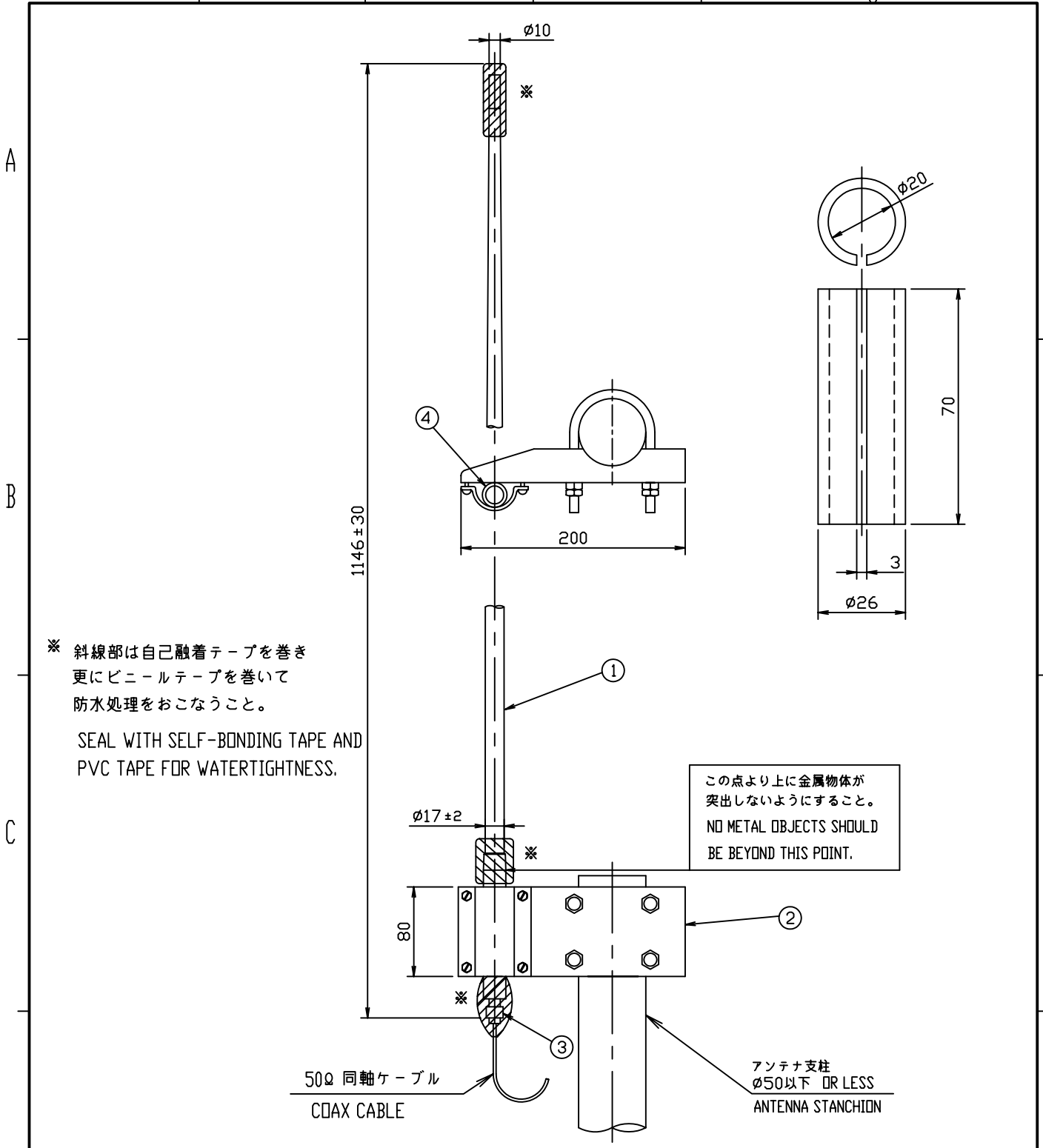

※ 斜線部は自己融着テープを巻き更にビニールテープを巻いて防水処理をおこなうこと。

SEAL WITH SELF-BONDING TAPE AND PVC TAPE FOR WATERTIGHTNESS.

この点より上に金属物体が突出しないようにすること。  
NO METAL OBJECTS SHOULD BE BEYOND THIS POINT.

4	固定用パイプ LINER PIPE	硬質塩ビ VINYL CHLORIDE	1		
3	同軸コネクタ COAX. CONNECTOR		1		M-R
2	アンテナ取付金具 ANTENNA BRACKET	SUS	1 式 SET	4-310071	0.6 kg
1	アンテナ棒 ANTENNA ELEMENT	FRP	1		0.25 kg
品番 ITEM	品名 NAME	材質 MATERIAL	数量 Q'TY	図番 DWG.No.	摘要 REMARKS

DRAWN	Feb. 1 '05	T.YAMASAKI	TITLE	FAB-151D
CHECKED	Feb. 1 '05	T.MATSUGUCHI	名称	150MHz ホイップアンテナ
APPROVED	Feb. 02 '05	T. Matsuguchi		外寸図
SCALE	1/5	MASS 0.85 ±10% kg	NAME	150MHz WHIP ANTENNA
DWG.No.	C5013-019- J	4-110718		OUTLINE DRAWING

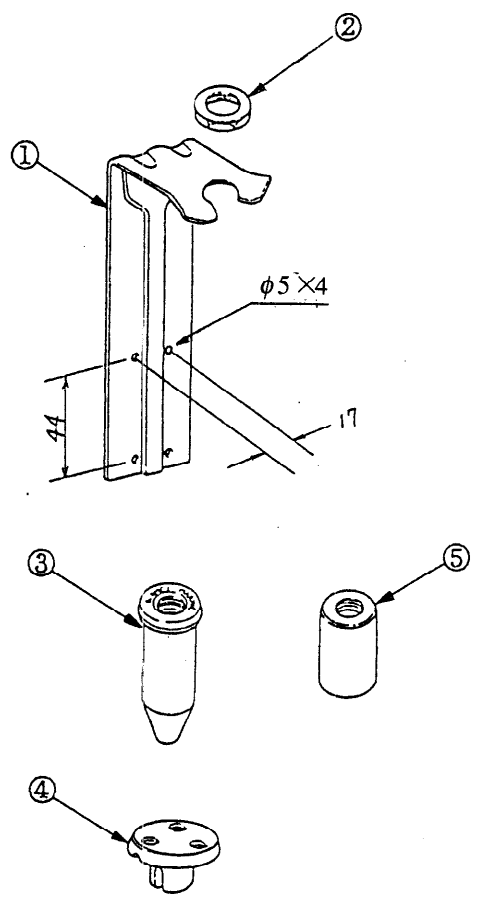
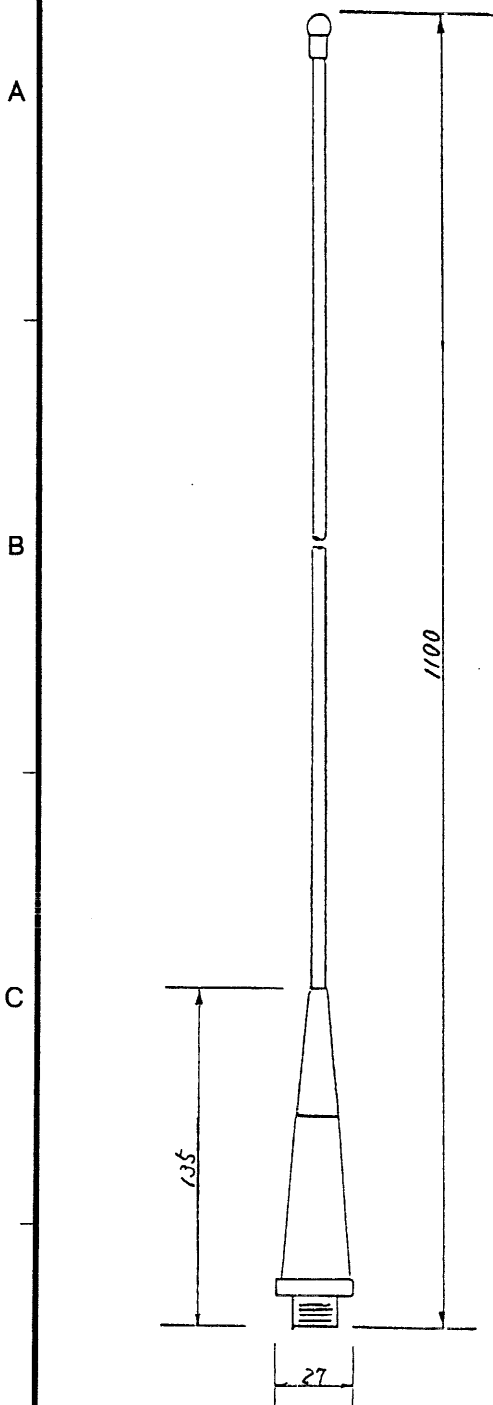

	品名 NAME	数量 QTY
1	アンテナ取付組品 ANTENNA BRACKET	1
2	固定ナット NUT	1
3	防滴カバー WATERPROOFING COVER	1
4	グランド GLAND	1
5	アダプタ ADAPTER	1

付属品；M型コネクタ付同軸ケーブル組品(05S9014, 5 m)  
 Antenna RA106 comes with a coax cable assembly (05S9014, 5 m)  
 which has an M-type connector attached.

DRAWN Nov. 13 '95 T. N. I. H. I. N. O.				TYPE RA106
CHECKED Nov. 13 '95 K. Okamoto				名称 150 MHz アンテナ外観図
APPROVED Nov. 13 '95 K. Okamoto	FM-2678 FM-8500			外寸図
SCALE α	MASS — kg	APPLICABLE TO: (MODEL.)	BLOCK NO.	NAME VHF MARINE ANTENNA
DWG NO. C5603-G02- A	05-001-4354- 0			OUTLINE DRAWING

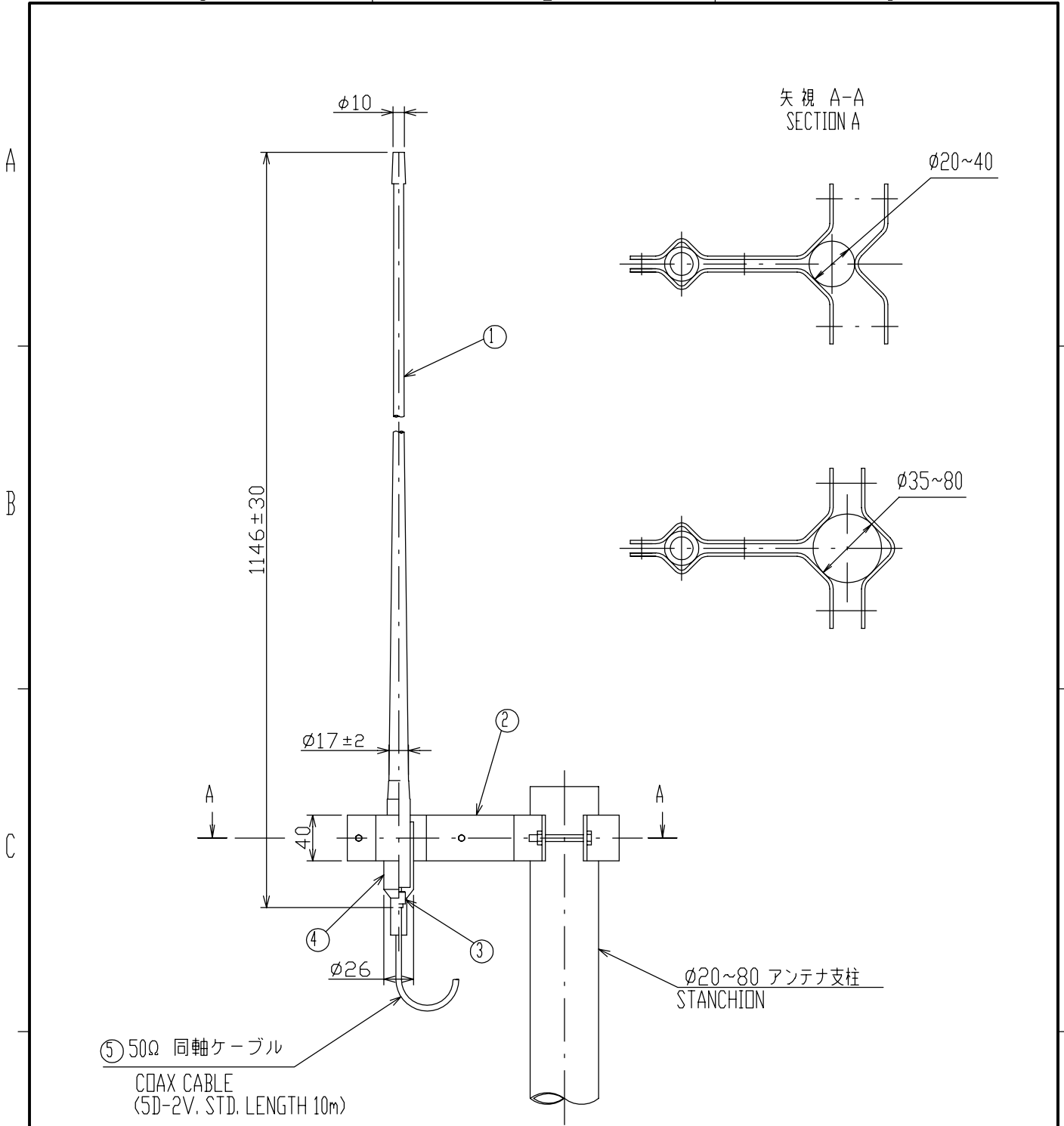

⑤ 50Ω 同軸ケーブル  
COAX CABLE  
(5D-2V, STD, LENGTH 10m)

5	同軸ケーブル 50Ω COAX. CABLE		10m	5D-2V	
4	掙ビキャップ CONNECTOR CAP		1		
3	同軸コネクタ COAX. CONNECTOR		2	M-P-5	
2	アンテナ取付金具 ANTENNA BRACKET		1 式 SET		t2
1	アンテナ棒 ANTENNA ELEMENT	FRP	1	150M-W2VN	0.25kg
品番 ITEM	品名 NAME	材質 MATERIAL	数量 Q.TY	図番 DWG.No.	摘要 REMARKS

DRAWN	Nov. 26 '03	T.YAMASAKI	TITLE	150M-W2VN	
CHECKED	Nov. 26 '03	T.TAKENO	名称	150MHzホイップアンテナ	
APPROVED	Nov. 28 '03	Matsuyuchi		外寸図	
SCALE	1/5	MASS 0.7 ±10% kg	NAME	150MHz WHIP ANTENNA	
DWG.No.	C5011-042- C			OUTLINE DRAWING	

表1 TABLE 1

寸法区分 (mm) DIMENSION	公差 (mm) TOLERANCE
$0 < L \leq 50$	$\pm 1.5$
$50 < L \leq 100$	$\pm 2.5$
$100 < L \leq 500$	$\pm 3$

A

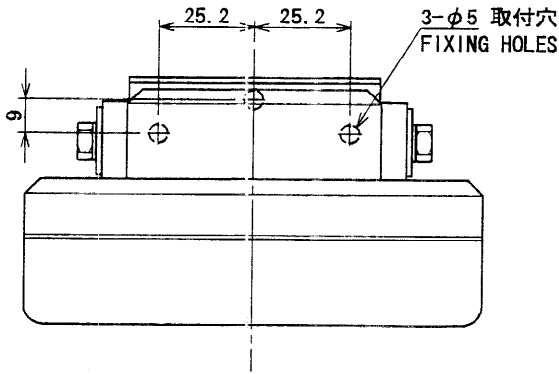

B

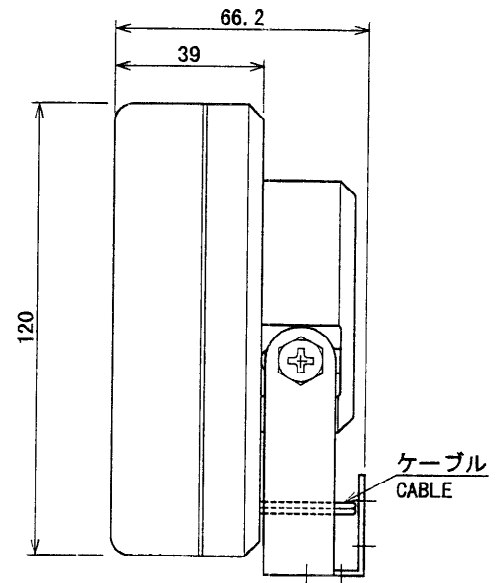
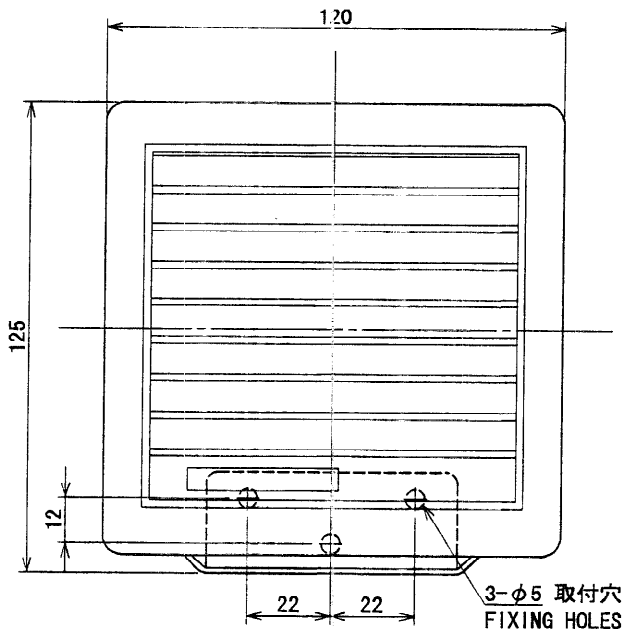

C

D

**注記**

1) 指定なき寸法公差は表1による。

**NOTE**

1. TABLE 1 INDICATES TOLERANCE OF DIMENSIONS.

DRAWN May 23 '01 T. YAMASAKI		TITLE SEM-21Q
CHECKED May 24 '01 T. Kimi		名称 スピーカ
APPROVED May 24 '01 Y. Kimi		外寸図
SCALE 1/2	MASS ±10% 0.54 kg	質量は2.8mケーブルを含む NAME LOUDSPEAKER
DWG. No. C5016-G07-A		OUTLINE DRAWING



