

FURUNO

Deep Sea Equipment

Installation Handbook

Edition-2

No part of this manual may be copied or reproduced without written permission.
If this manual is lost or worn, contact your dealer about replacement.
The contents of this manual and equipment specifications are subject to change without notice.



FURUNO ELECTRIC CO., LTD.
NISHINOMIYA, JAPAN



(Elemental Chlorine Free)

The paper used in this manual
is elemental chlorine free.

© **FURUNO ELECTRIC CO., LTD.**

9-52 Ashihara-cho,
Nishinomiya 662-8580, JAPAN

Telephone : 0798-65-2111

Fax : 0798-65-4200

FURUNO Authorized Distributor/Dealer

All rights reserved.

Printed in Japan

FIRST EDITION : JAN. 2007

Pub. No. TIE-00160-A

(NAYO) INSTALLATION

Introduction***Part-1. System Configuration***

1. INMARSAT B: FELCOM 82A/B	S-1
2. INMARSAT C: FELCOM 15 (GMDSS)	S-2
3. INMARSAT C: FELCOM 15 (GMDSS+SSAS)	S-3
4. INMARSAT C: FELCOM 16 (SSAS)	S-4
5. INMARSAT F: FELCOM 70	S-5
6. GMDSS Console: RC-1800F (150W/250W)	S-6
7. GMDSS Console: RC-1800F (400W)	S-7
8. X-Band Radar: FAR-2817/2827 (Two Unit Type)	S-8
9. S-Band Radar: FAR-2837S (Two Unit Type)	S-9
10. X-Band Radar: FAR-2827W (Tree Unit Type)	S-10
11. S-Band Radar: FAR-2837SW (Tree Unit Type)	S-11
12. Radar/ECDIS Network Configuration	S-12
13. ECDIS: FEA-2107/2807	S-13
14. U-AIS: FA-150	S-14
15. Weather FAX Receiver: FAX-210/214/215/410/30	S-15
16. NAVTEX Receiver: NX-700A/B	S-16
17. VDR (Voyage Data Recorder): VR-5000	S-17
18. VDR (Voyage Data Recorder): VR-3000/3000S	S-18
19. Doppler Speed Log: DS-80	S-19
20. Doppler Speed Log: DS-50	S-20
21. Doppler Speed Log: DS-30	S-21
22. Doppler Speed Log: DS-30	S-22
23. Navigational Echo Sounder: FE-700	S-23
24. Navigational Echo Sounder: FE-700	S-24

Part-2. Installation

Chapter 1. Radar

1.1 Arrangement of Antenna Mast	1-1
1.2 Installation of X-Band Radar	1-2
1.2.1 General Mounting of Radar antenna	1-2
1.2.2 Equipping the performance monitor: PM for X-Band Radar	1-3
1.2.3 Mounting of X-Band Radar: TR-UP Type antenna	1-4
1.2.4 Mounting of X-Band Radar: TR-DOWN type antenna	1-7
1.2.5 Installation of Flexible Wave-Guide: TR-DOWN type	1-9
1.2.6 Mounting of X-Band Radar TR unit: TR-DOWN type	1-12
1.2.7 Fabricating Wave-guide	1-14
1.3 Installation of S-Band Radar	1-19
1.3.1 Mounting of Radar antenna	1-19
1.3.2 Mounting of S-Band Radar: TR-UP type antenna	1-21
1.3.3 Mounting of S-Band Radar: TR-DOWN type antenna	1-23
1.3.4 Laying coaxial cable of S-Band Radar	1-25
1.3.5 Mounting of S-Band Radar: TR-UP type Transceiver unit	1-27
1.3.6 Fabrication of coaxial cable and connector	1-28
1.4 Installation of Radar Console	1-36

Chapter 2. ECDIS

2.1 Installation of ECDIS Console	2-1
2.1.1 Mounting of ECDIS console	2-1
2.1.2 Wiring of ECDIS console	2-2
2.2 Custom Ordered Console	2-10
2.2.1 Installation	2-10
2.2.2 Wiring of Console	2-10
2.3 Connection of EXT. Monitor for ECDIS	2-14

Chapter 3. MF/HF Radio

3.1 Installation of MF/HF Antenna No.1	3-1
3.1.1 Mounting of Antenna	3-1
3.1.2 Mounting of Antenna coupler	3-5

3.2 Installation of MF/HF Antenna No.2	3-7
3.2.1 Mounting of antenna	3-7
3.3 Installation of Radio Console	3-12
3.3.1 General Mounting of Radio console	3-12
3.3.2 Mounting of RC-1800F console (150/250W: FS-1570/2570)	3-14
3.3.3 Mounting of RC-1800F console (400W: FS-5000)	3-21
3.4 Installation of RX antenna	3-24
3.4.1 Mounting of Antenna junction box	3-24
3.4.2 Installation of Antenna with Pre-amplifier	3-25
3.5 Installation of Reserve source (Battery)	3-27
3.5.1 Lead-acid battery	3-27
3.5.2 Maintenance Free battery	3-29

Chapter 4. VHF Radio

4.1 Installation of VHF Antenna	4-1
4.2 Installation of VHF Console	4-3
4.3 Installation of Remote Station	4-5
4.4 Installation of VHF Wing Handset	4-7

Chapter 5. INMARSAT

5.1 General installation of Inmarsat Antenna	5-1
5.2 Installation of INMARSAT B	5-2
5.2.1 Antenna unit	5-2
5.2.2 Radio frequency Radiation hazard label	5-3
5.2.3 Connecting Coaxial cable in Radome (FELCOM 82)	5-4
5.2.4 Installation of Transceiver unit and Junction box	5-4
5.2.5 Mounting of FELCOM 82 Handset and TEL Distress Button unit	5-5
5.3 Installation of INMARSAT C	5-6
5.3.1 Mounting of Antenna unit	5-6
5.3.2 Mounting of Terminal unit	5-9
5.3.3 Installation of SSAS unit	5-11

5.4 Installation of INMARSAT F	5-15
5.4.1 Mounting of Antenna unit	5-15
5.4.2 Radio frequency Radiation hazard label	5-16
5.4.3 Mounting of BDE	5-17
5.4.4 Wiring of Communication unit	5-18
5.4.5 Wiring of Distress Alert unit	5-20
5.4.6 Connection of ISDN devices	5-21
5.4.7 Connection of Analogue Telephone/G3 FAX (option)	5-22

Chapter 6. NAVTEX/FAX

6.1 Installation of NAVTEX	6-1
6.1.1 Mounting of NAVTEX antenna	6-1
6.1.2 NAVTEX Display unit	6-2
6.1.3 NAVTEX Receiver unit	6-3
6.2 Installation of FAX Receiver	6-4
6.2.1 Mounting of Antenna	6-4
6.2.2 Installation of FAX Receiver	6-6

Chapter 7. GPS

7.1 Mounting of GPS antenna	7-1
7.2 Mounting of GPS Display unit	7-4
7.3 Mounting of GPS Multi-Distributor	7-5

Chapter 8. U-AIS

8.1 Mounting of AIS antenna	8-1
8.2 Mounting of AIS Display and Transponder units	8-2
8.2.1 AIS Display unit: FA-1502	8-2
8.2.2 AIS Transponder unit: FA-1501	8-3
8.2.3 AIS Power Supply: PR-240-CE	8-4
8.2.4 Pilot Plug	8-5

Chapter 9. VDR

9.1 VR-5000: Installation of Data Collecting unit (DCU) 9-1
 9.1.1 Mounting of DCU 9-1
 9.1.2 Wiring of DCU 9-4

9.2 VR-5000: Installation of Remote Alarm Panel and MIC 9-6
 9.2.1 Remote alarm panel 9-6
 9.2.2 Mounting of Bridge Microphone 9-7
 9.2.3 Mounting of Wing Microphone 9-9

9.3 VR-5000/VR-3000: Installation of DRU 9-11
 9.3.1 Mounting of DRU 9-11
 9.3.2 Fixing DRU 9-12
 9.3.3 Connection of DRU 9-13

9.4 Installation of VR-3000 9-16

Chapter 10. Life-saving Appliance

10.1 Installation of SART 10-1

10.2 Installation of Two-Way VHF Radio 10-2

10.3 Installation of EPIRB 10-4

Chapter 11. Navigational Echo Sounder

11.1 Laying the Transducer cable 11-1

11.2 Inner Hull Tank 11-2

11.3 Installation of Display unit and Distribution box: FE-700 11-6
 11.3.1 Mounting of Display unit 11-6
 11.3.2 Mounting of Distribution box 11-7
 11.3.3 Mounting of Matching box 11-8
 11.3.4 Mounting of Transducer cable/flange 11-9

Chapter 12. Doppler Sonar

12.1 Laying the Transducer cable **12-1**

12.2 Installation of DS-30 transducer **12-2**

 12.2.1 Hull fixed tank 12-2

 12.2.2 Gate-valve Tank 12-7

12.3 Installation of DS-50 transducer **12-10**

 12.3.1 Hull tank 12-10

 12.3.2 Installing tank with Gate-valve 12-13

12.4 Installation of DS-80 transducer **12-19**

 12.4.1 Gate-valve tank: DS-782 12-19

 12.4.2 Gate-valve tank: DS-786 12-22

 12.4.3 Hull tank: DS-783 12-25

 12.4.4 Hull Tank : DS-784 12-26

 12.4.5 Protruded hull tank 12-28

12.5 Example of installations **12-29**

 12.5.1 Example of DS-50 installation 12-29

 12.5.2 Example of DS-30 installation 12-35

Appendix 1. Acoustic Equipment

AP1.1 Transducer Position (DS-30/50/80, FE-700) **AP1-1**

AP1.2 Piping Transducer cable **AP1-5**

AP1.3 Installation on ship with protruded keel **AP1-6**

Appendix 2. Antenna Installation

AP2.1 Safety measures **AP2-1**

AP2.2 Antenna arrangement **AP2-3**

AP2.3 Table of antenna interactions **AP2-16**

Appendix 3. Radar Waveguide

AP3.1 Waveguide for X-Band Radar **AP3-1**

AP3.2 Waveguide for S-Band Radar **AP3-8**

Appendix 4. Cables

AP4.1 Power cable	AP4-1
AP4.2 Coaxial cable	AP4-8

Appendix 5. Basic Skill

AP5.1 Cable Termination	AP5-1
AP5.2 How to solder	AP5-9
AP5.3 Waterproofing by taping	AP5-15

This page is intentionally left blank.

The present document summarizes basic matters in installation. Be sure to see the installation manual.

Even if your case does not fall under any installation cases stipulated in this document, we hope that you would understand the purpose and properly dispose of your case.

1. Grounding of the equipments is required to prevent electric shock and noise. Be sure to ground the equipments without fault.
2. It shall not be thought that signal lines of cables only constitute electric wiring. "Armour" and "Shield" of cables are also important electric circuits (ground-circuits). Connect them to the specified places.
3. Consider water leakage and corrosion (electrolytic corrosion). For example, apply taping or silicon sealant to prevent these.
4. Secure the cable wiring length with maintenance taken into account. For example, excessively short cable length between equipment and cable entrance to the unit prevents the unit from being pulled out.
5. Identify the connection to the cable.
6. Even if a wiring place is hidden, wire carefully, neatly, securely and in a proper cable length. In addition, be sure to wiring of the equipments without fault.
7. Use terminal crimper tools, soldering irons, screwdrivers, and other tools that are properly for the purpose.

Points to consider in installation

1. Equipment under the installation

Equipment to be installed is precision instruments apparatus. In addition, they are user's property. While installing is underway, cover the equipment with vinyl sheet, etc. to prevent dust and damage. Protect the conductor of coaxial cables and signal cables of outboard wiring with taping, etc. to prevent exposure to rain.



2. Cabling

2.1 When a unit is installed under a table, etc., give consideration to the cable length so that the unit could be pulled out for easy maintenance.

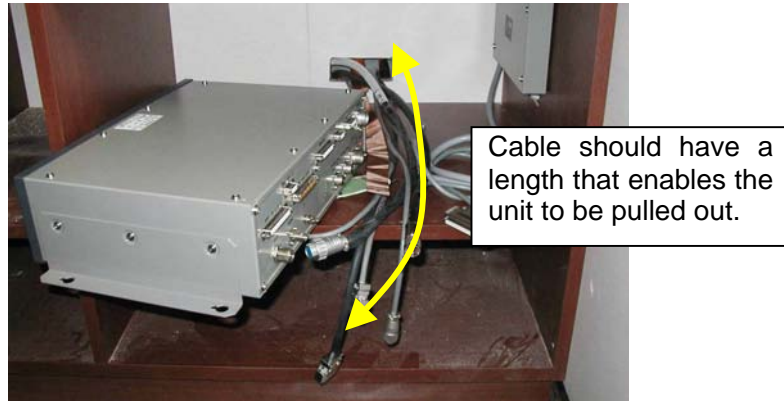

2.2 Armour cable

In general, it is required that metal covering of equipment at voltage exceeding safety-voltage and metal covering of cable (Armour) should be grounded. Safety-voltage means 50 V or lower between conductors, or between conductor and ground.

Based on this, the armour of armour cables, which are connected to the equipment should be grounded to the ship body at the coming outlet, and if it is unable to provide grounding to the hull at the coming outlet, it should be grounded by a cable clamp of equipment.

Armour is connected to the designated place in connection drawings or installation manual, follow the method.

Apply taping to the armour peeled off portion or cable sheath peeled off portion.

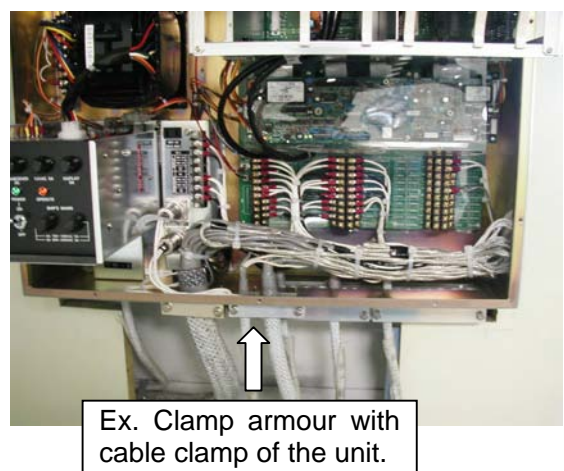
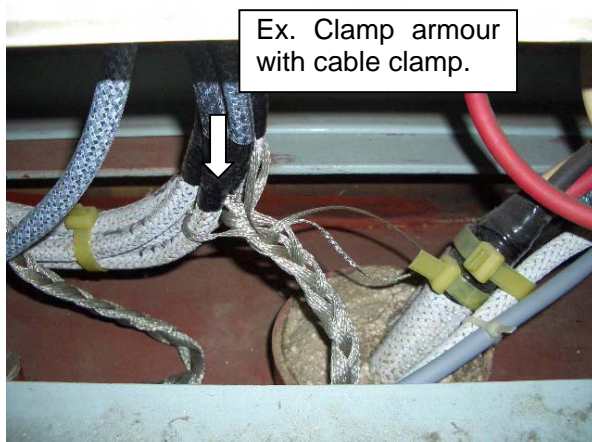

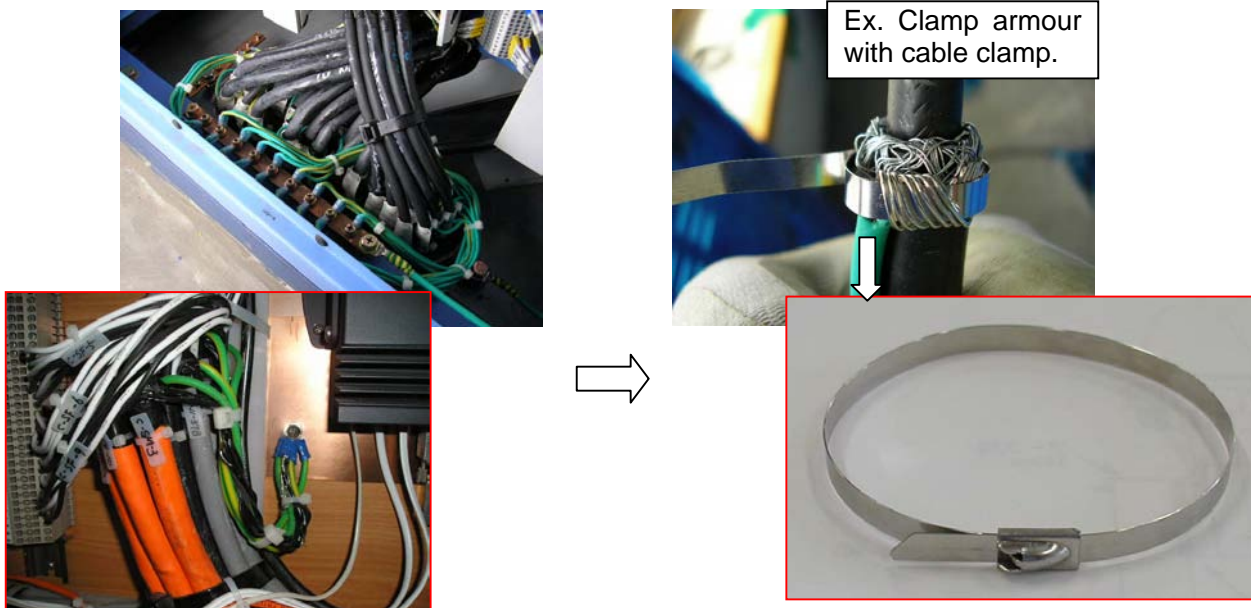

2.3 Shield wire

Insulate the shield wire by taping or heat shrink tubing, and connect (ground) to designated place in the connection drawing or installation manual.

For example, use a Crimp-on lugs when connecting to chassis of equipment. In addition, protect the shield wire with taping or heat shrink tubing to prevent shorting to electrical circuits.

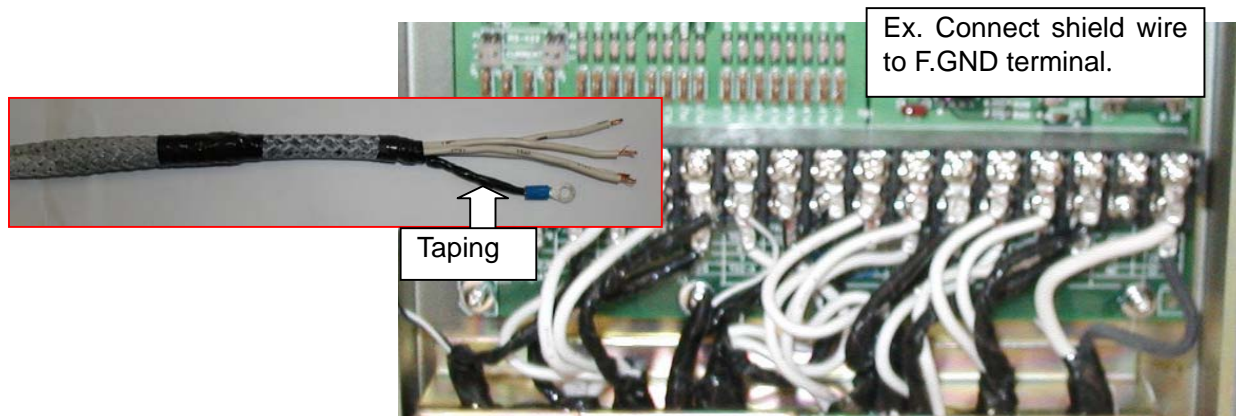

3. Grounding

Be sure to ground the unit to prevent electric shock and noise prevention. Grounding of the antenna coupler contributes to noise prevention and sensitivity improvement.

The concept of grounding is to use a thick and short conductor. Use ground wires and ground copper strap thicker (wider) than those designated in connection drawings.

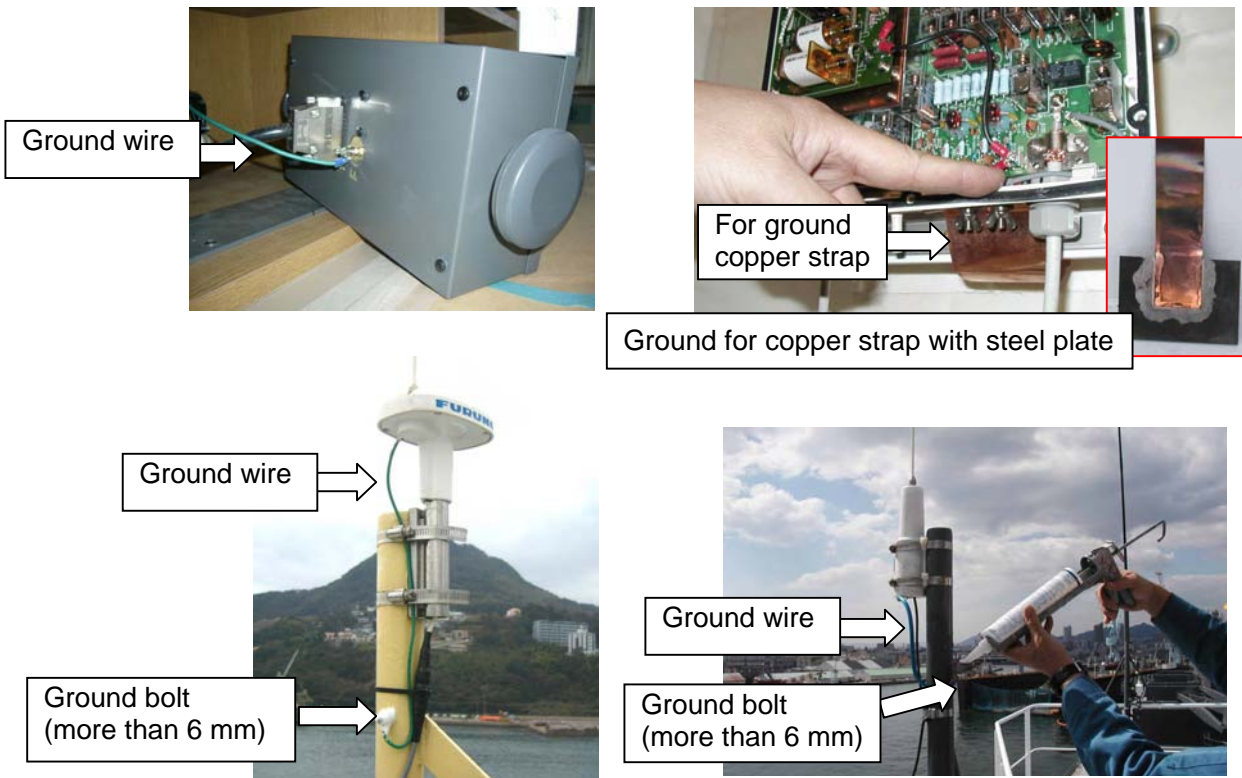

4. Coaxial connector

Coaxial connectors should be surely processed using appropriate connectors suited to coaxial cables. After attach the antenna cable connector, it must be cable check.

In the case of M-type coaxial connectors, if any “loose” occurs when the shell and coaxial cable are twisted, the attachment is not successful.

In the case of N-type coaxial connectors, protruded pins, retracted pins more than required or bent pins, the attachment is not correct. Furthermore, any loose that occurs when coaxial connector or coaxial cables are pulled or pressed, the attachment is not successful.

5. Waterproof and corrosion

Exposed ground connected portions and cable glands of units installed outboard should be protected with silicon sealant or putty without fault to prevent water leakage and corrosion. In addition, any portion where water leakage might occur, such as coaxial cable connector connected portions should be applied with taping using self-bonding tape and vinyl tape.

Also, applying silicon sealant to mounting bolts, etc. can prevent slackening of bolts.

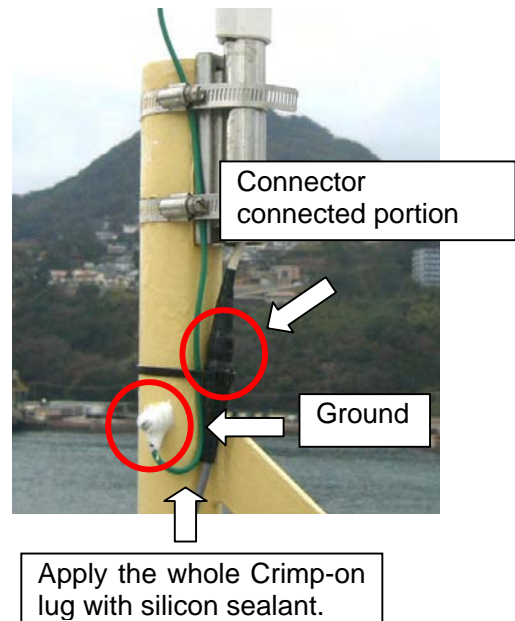
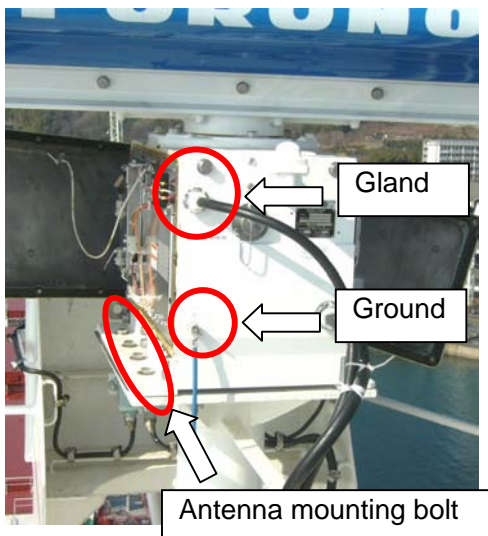

Water leakage/corrosion prevented portions	Methods
Ground connections of each unit	Silicon sealant or putty
Ground connections of antenna post	Silicon sealant or putty
Coaxial connector connections	Self-welding tape + plastic tape
Radar and INMARSAT mounting bolts	Silicon sealant or putty
VHF antenna element mounting portions	Self-welding tape + plastic tape
Antenna with PRE-AMP mounting portions	Silicon sealant or putty
Unit gland part	Silicon sealant or putty
Miscellaneous places where water leakage may occur	Self-welding tape + plastic tape, Silicon sealant or putty

Reference: Electrolytic corrosion

The silicon sealant is applied to antenna mounting bolts.

This is to prevent electrolytic corrosion, which is generated by contact between Radar antenna (aluminum- chassis) and antenna base (iron), and dissimilar metal of mounting bolts (stainless steel). Conditions of electrolytic corrosion include existence of moisture.

Consequently, to prevent electrolytic corrosion, silicon sealant should be used to prevent moisture from existing at the mounting portion.

The antenna bracket should be properly mounted.

Excessively tightening the bracket with unnecessarily strong force will not only deform the bracket but also peels off paint of antenna mounting mast and from this portion, corrosion of the mast begins.

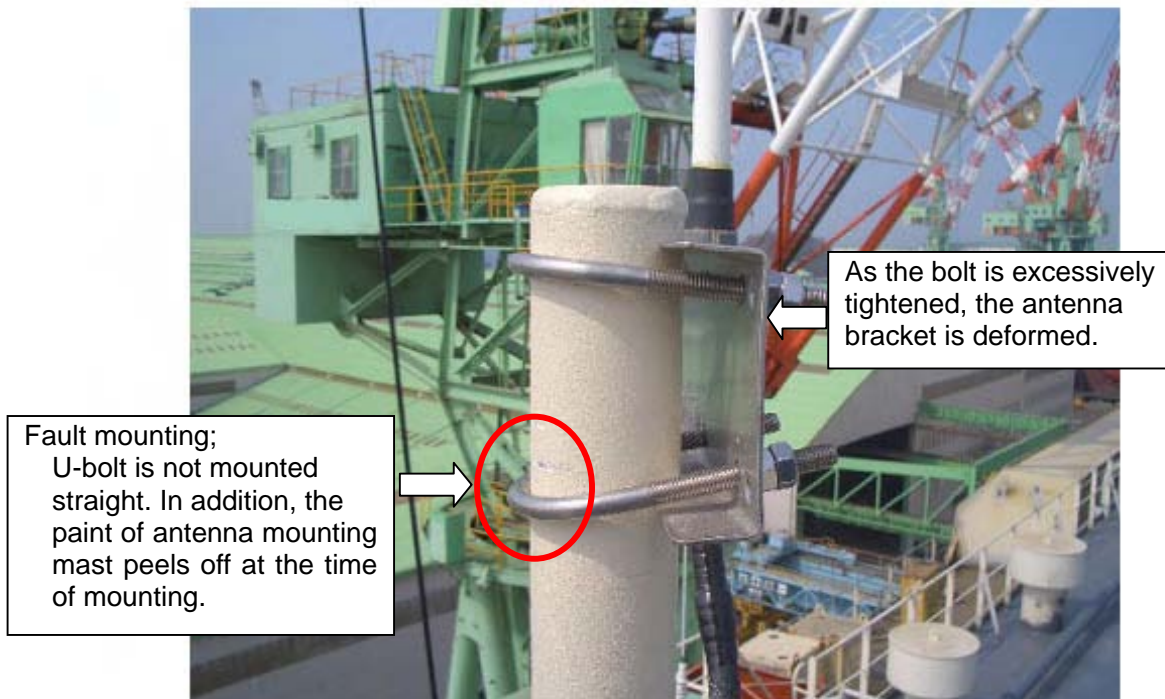

6. Fixing of cables

When cables are fixed with stainless band, tighten the stainless band with proper force with care to prevent damage to the cable. If the cable sheath is damaged, water leaks from the portion and corrodes the cable.

In addition, when cables are fix with cable tie, use weather-resistant.

Weather-resistant cable tie

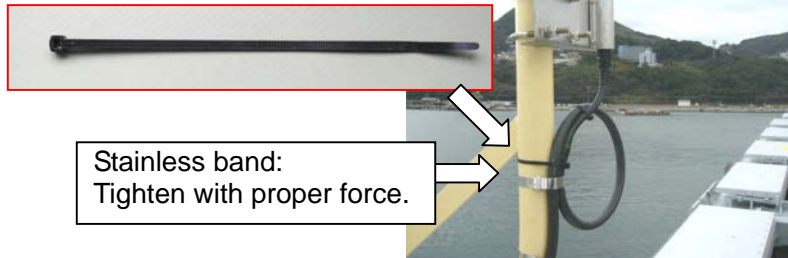

Unless the cable is securely fixed, the cable is chafed against the antenna pole and damaged.

For example, coaxial cables of GPS antenna and INMARSAT C antenna should be allowed to put through the mounting bracket pipe. In such event, the pipe head end and the coaxial cable are chafed to each other, and the coaxial cable is damaged. To prevent it, they are protected by vinyl tape or silicon sealant.

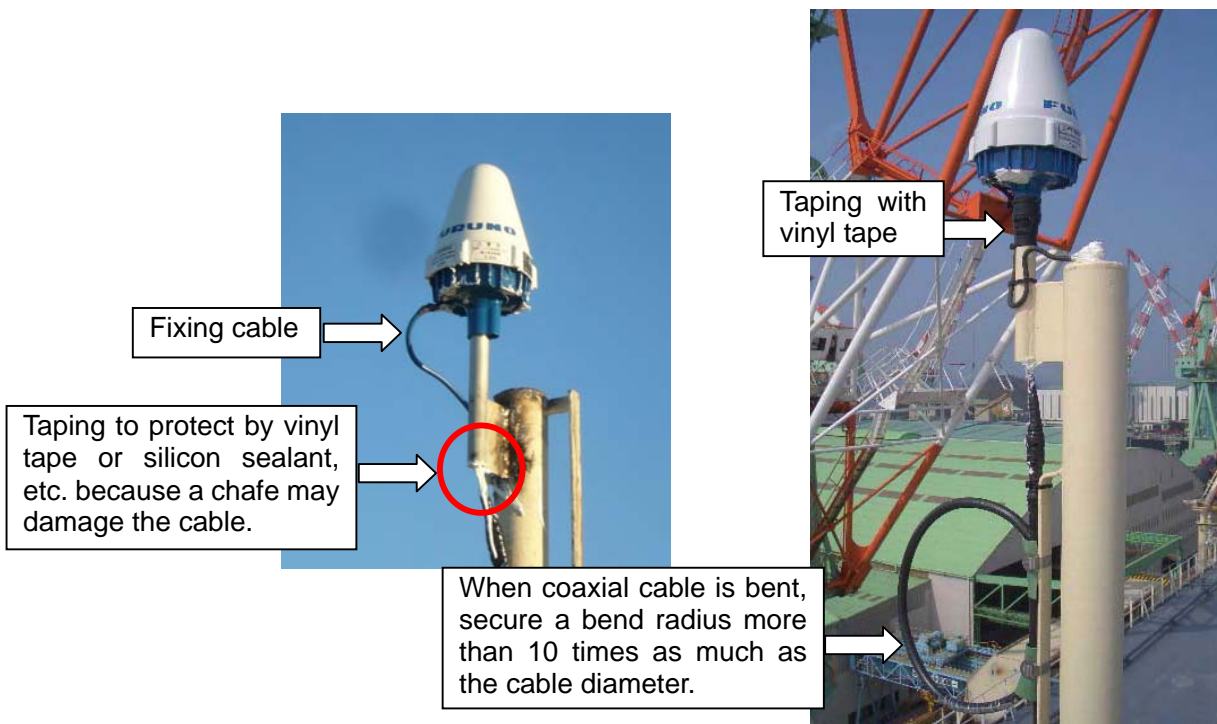

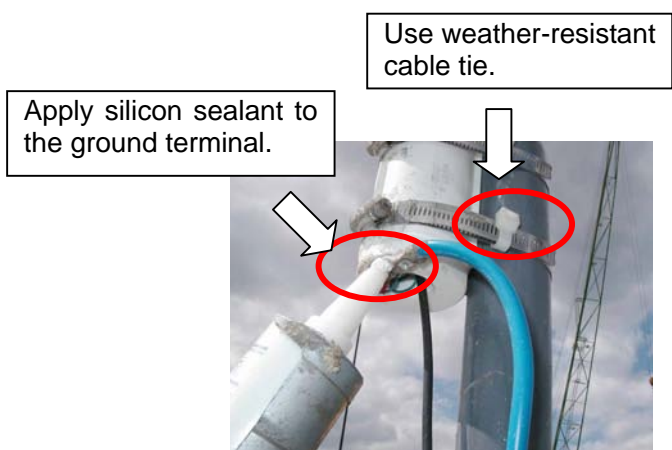
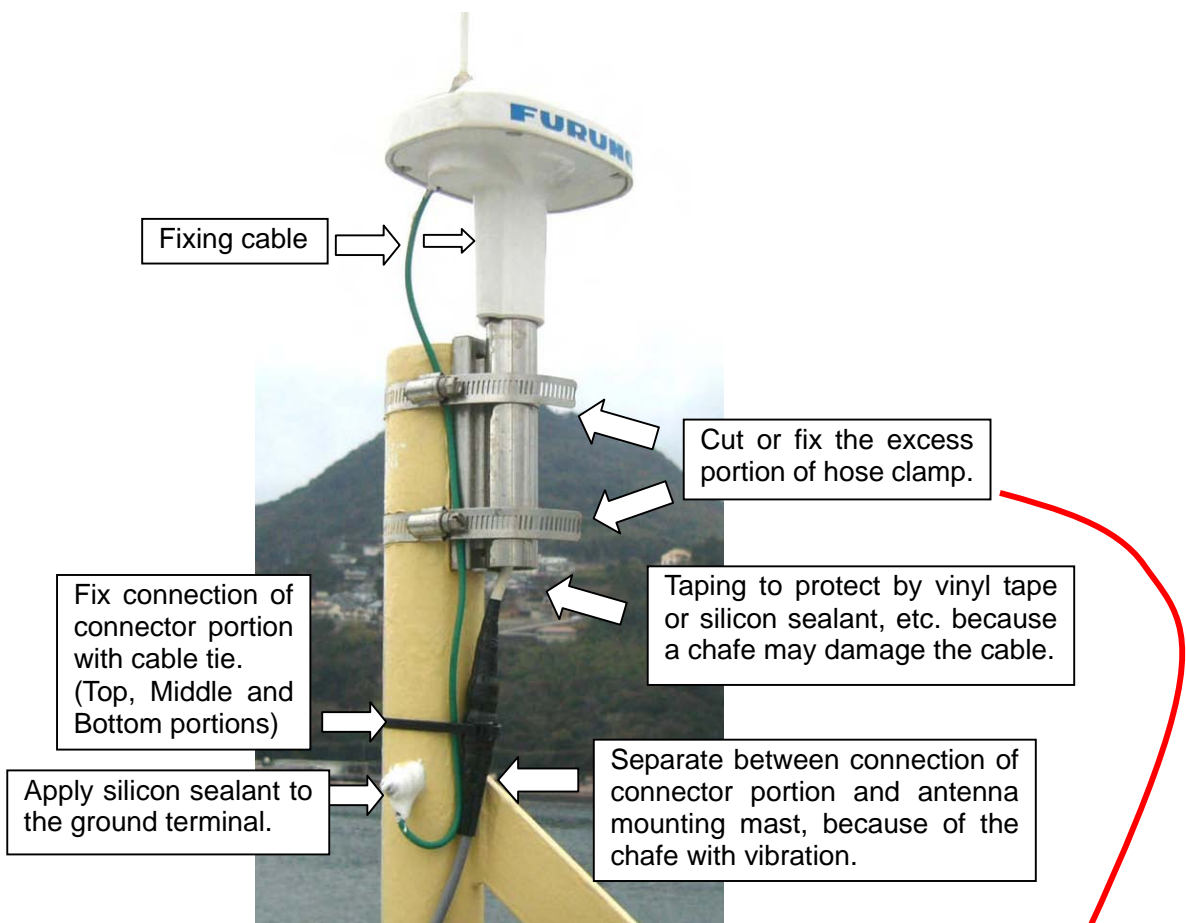

7. Wiring

Connect wires carefully, neatly, and securely.

When wires are fixed by cable tie, etc., bundle core wires of the cable to easily check wiring later, or connect wires in accord with the signals related to each other.

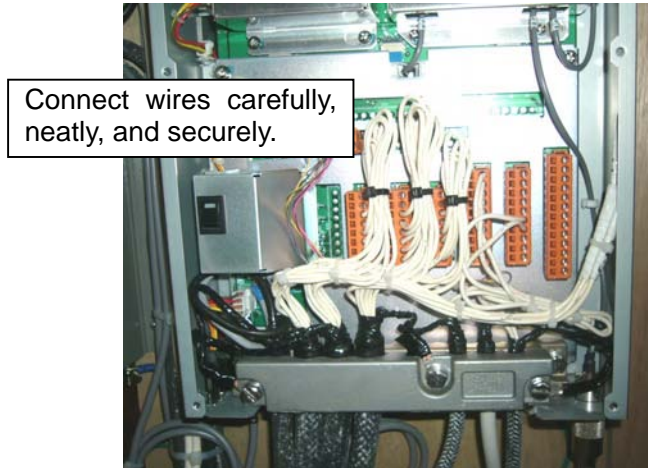

Where should be connected the “Armour” and the “Shield wire”?

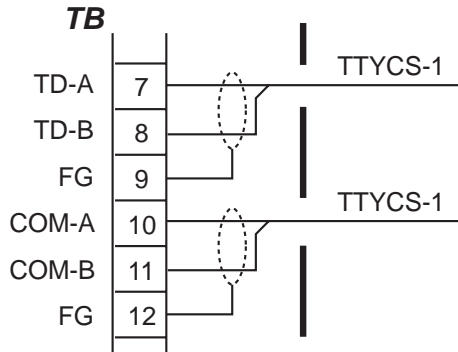

In the case of the drawing on the left, connect the shield wire to the number of the designated terminal board. “Armour” is not particularly designated. It would be appropriate to ground at the coming outlet.

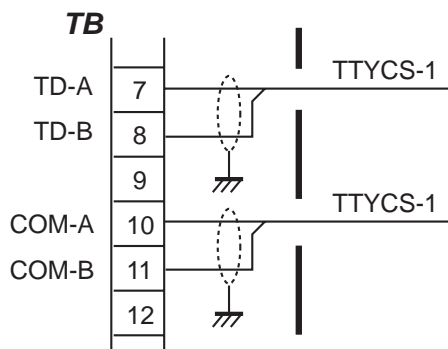

In the case of the drawing on the left, connect the shield wire to the chassis inside the equipment. For example, tighten together with the P.C.B fixing screw; then, connect to the screw on the chassis using a crimp-on lug. “Armour” is not particularly designated. It would be appropriate to ground at the coming outlet.

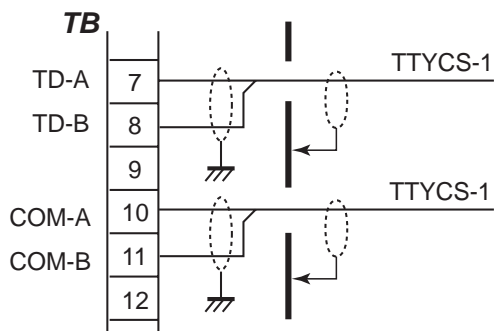

In the case of the drawing on the left, connect the shield wire to the chassis inside the equipment. For example, tighten together with the P.C.B fixing screw; then, connect to the screw on the chassis using a crimp-on lug. Clamp "Armour" at the cable clamp portion of the equipment.

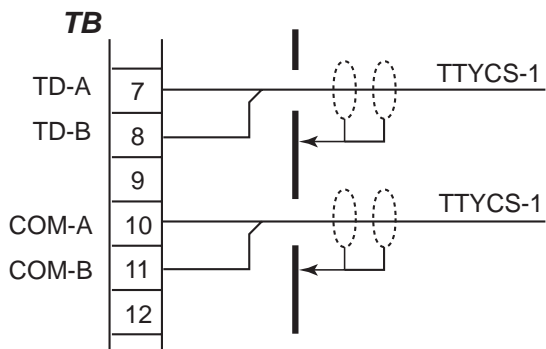

In the case of the drawing on the left, clamp the "Armour" and the "Shield wire" at the cable clamp portion of the equipment.

Part-1

System Configuration

The system configurations diagram described here is not all. General system configurations are described.

- | | |
|------|--|
| S-1 | 1. INMARSAT B: FELCOM 82A/B |
| S-2 | 2. INMARSAT C: FELCOM 15 (GMDSS) |
| S-3 | 3. INMARSAT C: FELCOM 15 (GMDSS + SSAS) |
| S-4 | 4. INMARSAT C: FELCOM 16 (SSAS) |
| S-5 | 5. INMARSAT F: FELCOM 70 |
| S-6 | 6. GMDSS Console: RC-1800F (150W/250W) |
| S-7 | 7. GMDSS Console: RC-1800F (400W) |
| S-8 | 8. X-Band Radar: FAR-2817/2827 (Two Unit Type) |
| S-9 | 9. S-Band Radar: FAR-2837S (Two Unit Type) |
| S-10 | 10. X-Band Radar: FAR-2827W (Tree Unit Type) |
| S-11 | 11. S-Band Radar: FAR-2837SW (Tree Unit Type) |
| S-12 | 12. Radar/ECDIS Network Configuration |
| S-13 | 13. ECDIS: FEA-2107/2807 |
| S-14 | 14. U-AIS: FA-150 |
| S-15 | 15. Weather FAX Receiver: FAX-210/214/215/410/30 |
| S-16 | 16. NAVTEX Receiver: NX-700A/B |
| S-17 | 17. VDR (Voyage Data Recorder): VR-5000 |
| S-18 | 18. VDR (Voyage Data Recorder): VR-3000/3000S |
| S-19 | 19. Doppler Speed Log: DS-80 |
| S-20 | 20. Doppler Speed Log: DS-50 |
| S-21 | 21. Doppler Speed Log: DS-30 |
| S-22 | 22. Doppler Speed Log: DS-30 |
| S-23 | 23. Navigational Echo Sounder: FE-700 |
| S-24 | 24. Navigational Echo Sounder: FE-700 |

2. INMARSAT C: FELCOM 15 (GMDSS)

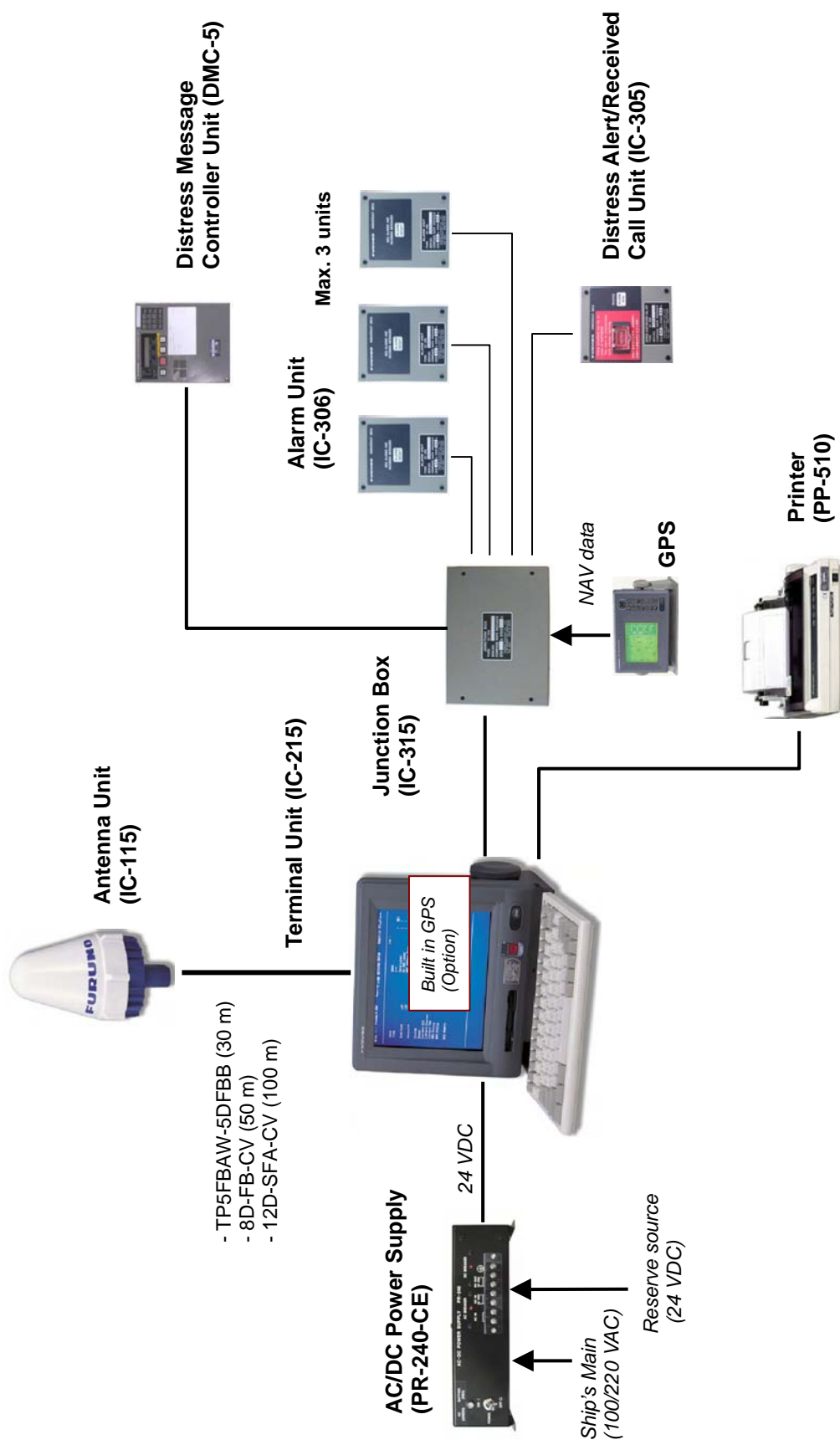

3. INMARSAT C: FELCOM 15 (GMDSS + SSAS)

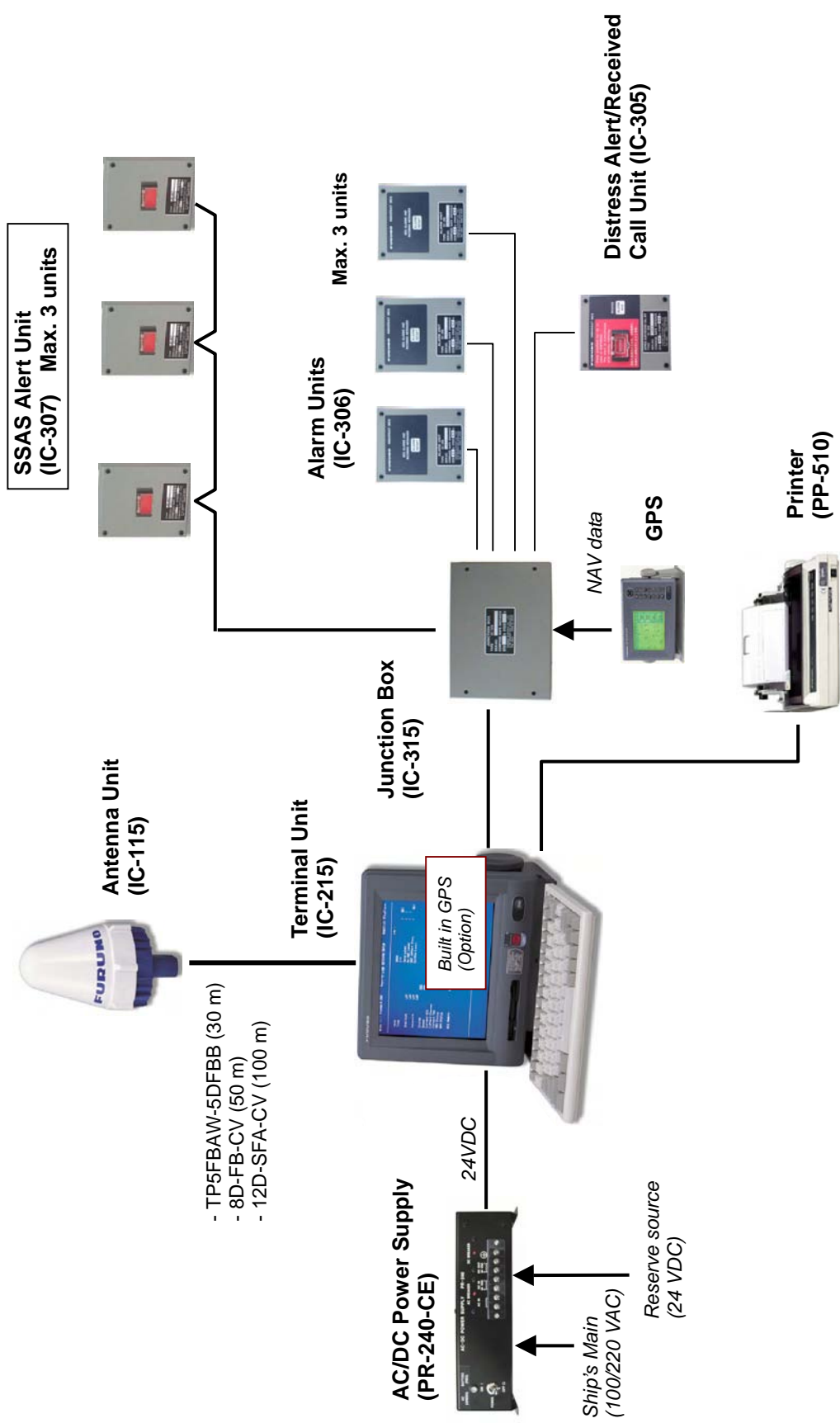

4. INMARSAT C: FELCOM 16 (SSAS)

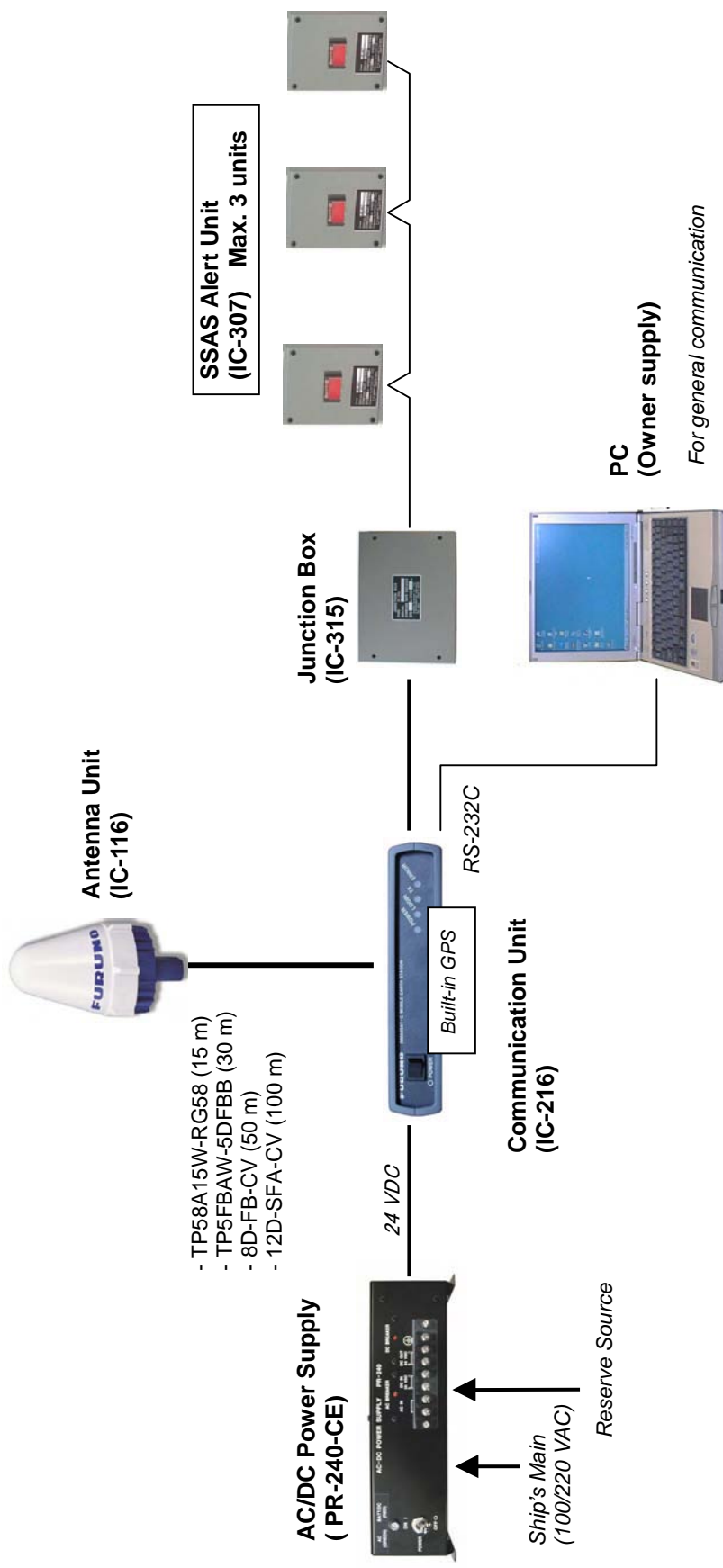

5. INMARSAT F: FELCOM 70

- ISDN device: Max. 7
- Note: Service of ISDN port: vLite Mobile and MPDS = NO
UDI = YES
- ISDN Bus: line Max. 100 m long
- Analogue port line: Max. 150 m long

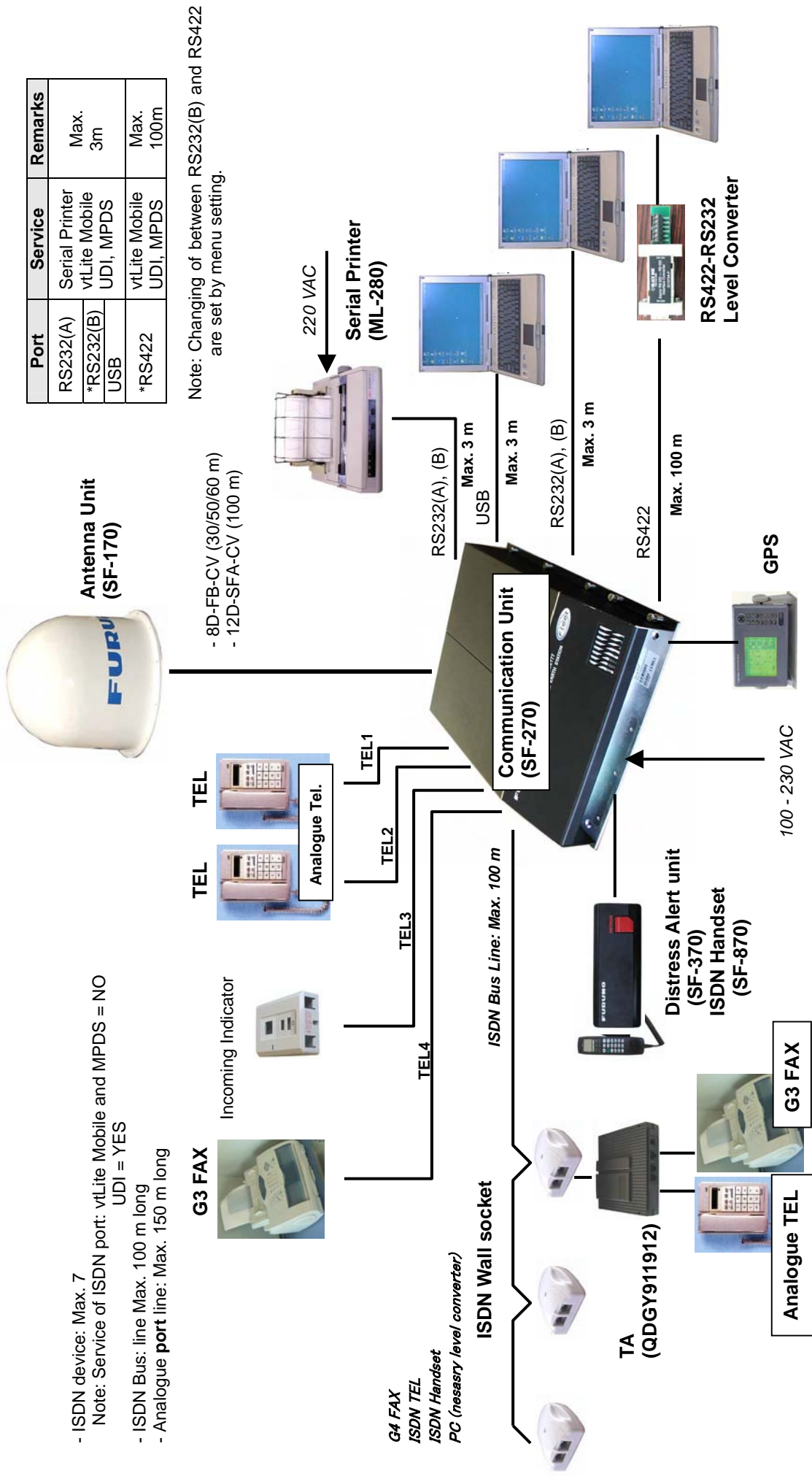

Port	Service	Remarks
RS232(A)	Serial Printer	Max. 3m
*RS232(B)	vLite Mobile	
USB	UDI, MPDS	
*RS422	vLite Mobile	Max. 100m
	UDI, MPDS	

6. GMDSS Console: RC-1800F (150W/250W)

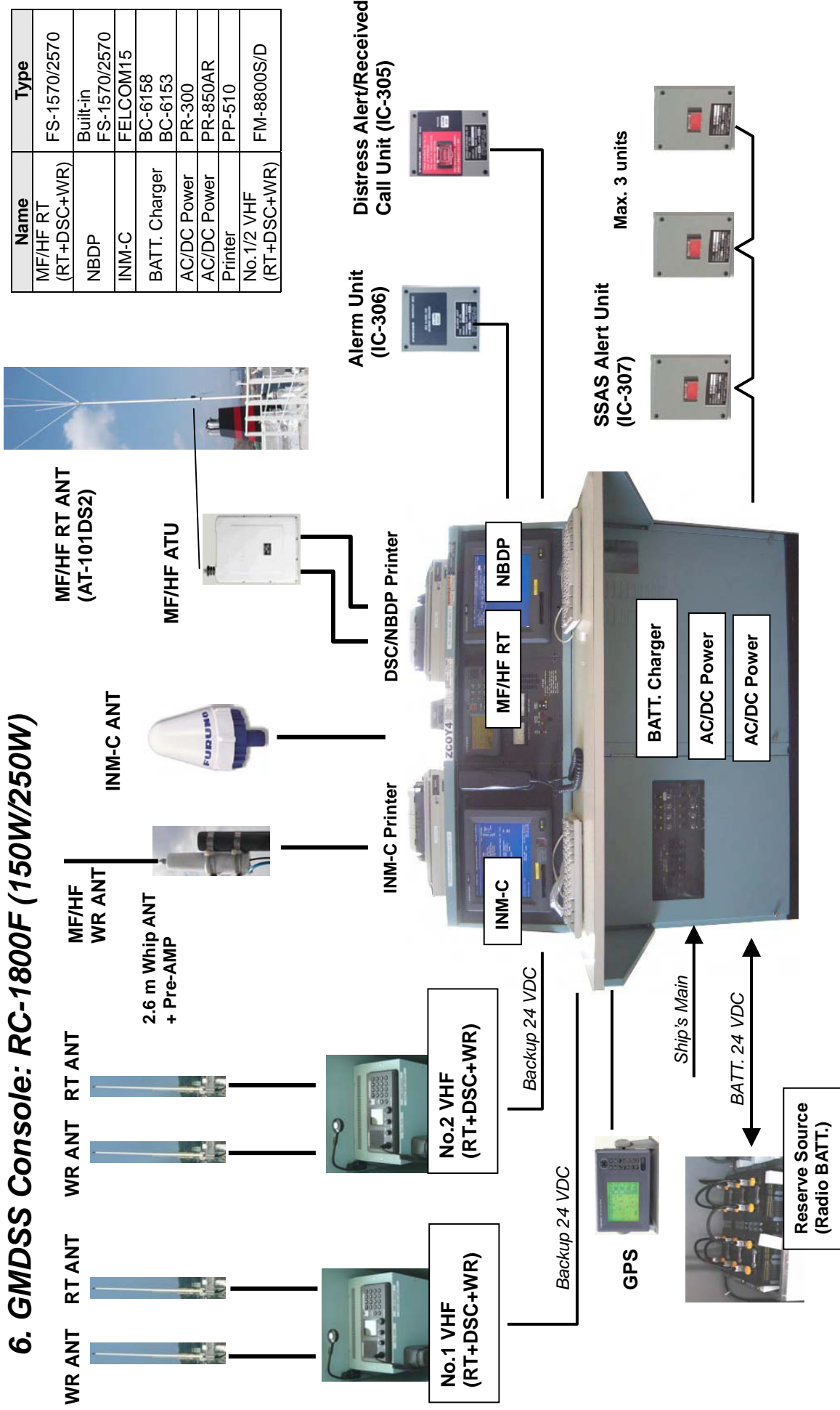

7. GMDSS Console: RC-1800F (400W)

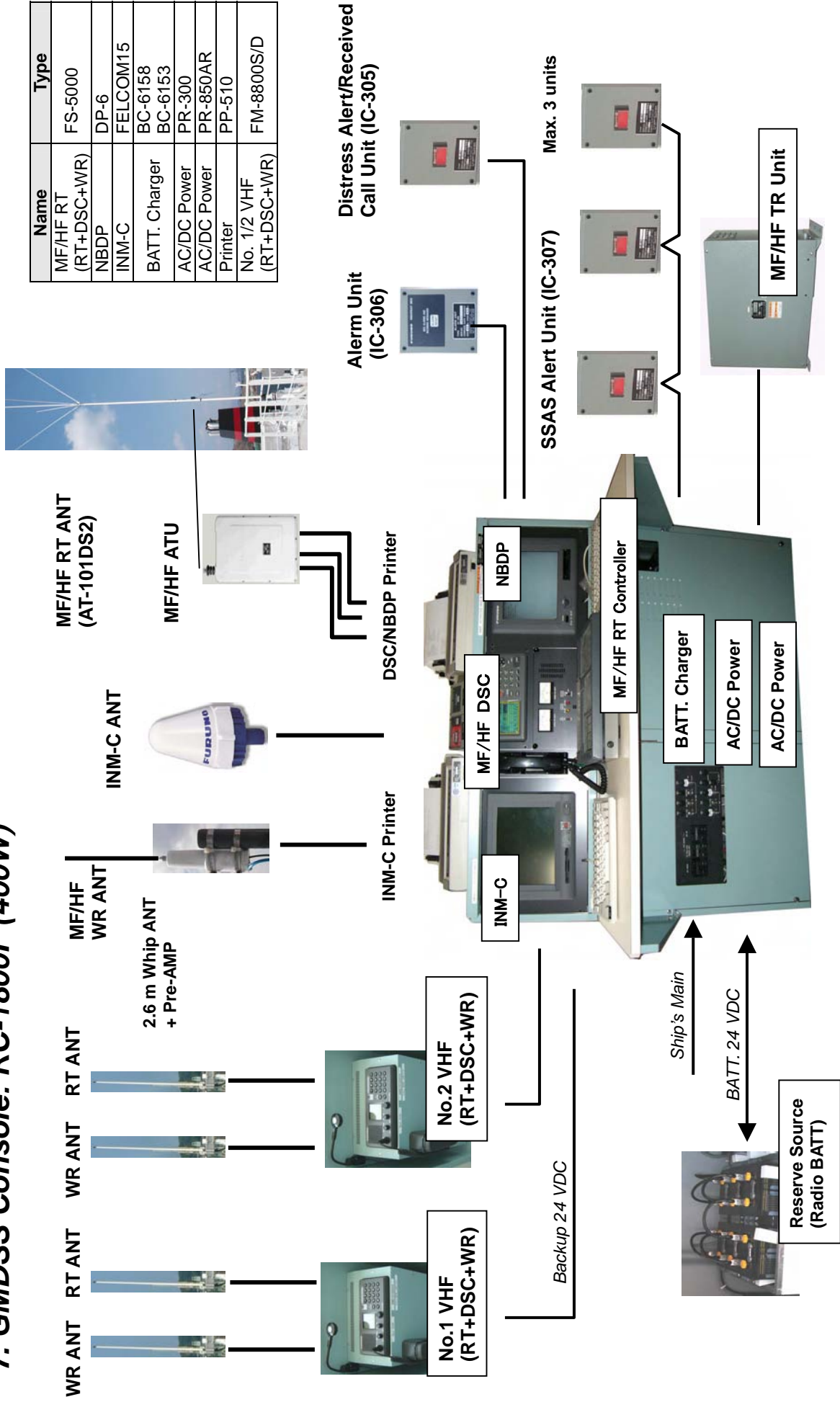

8. X-Band Radar: FAR-2817/2827 (Two Unit Type)

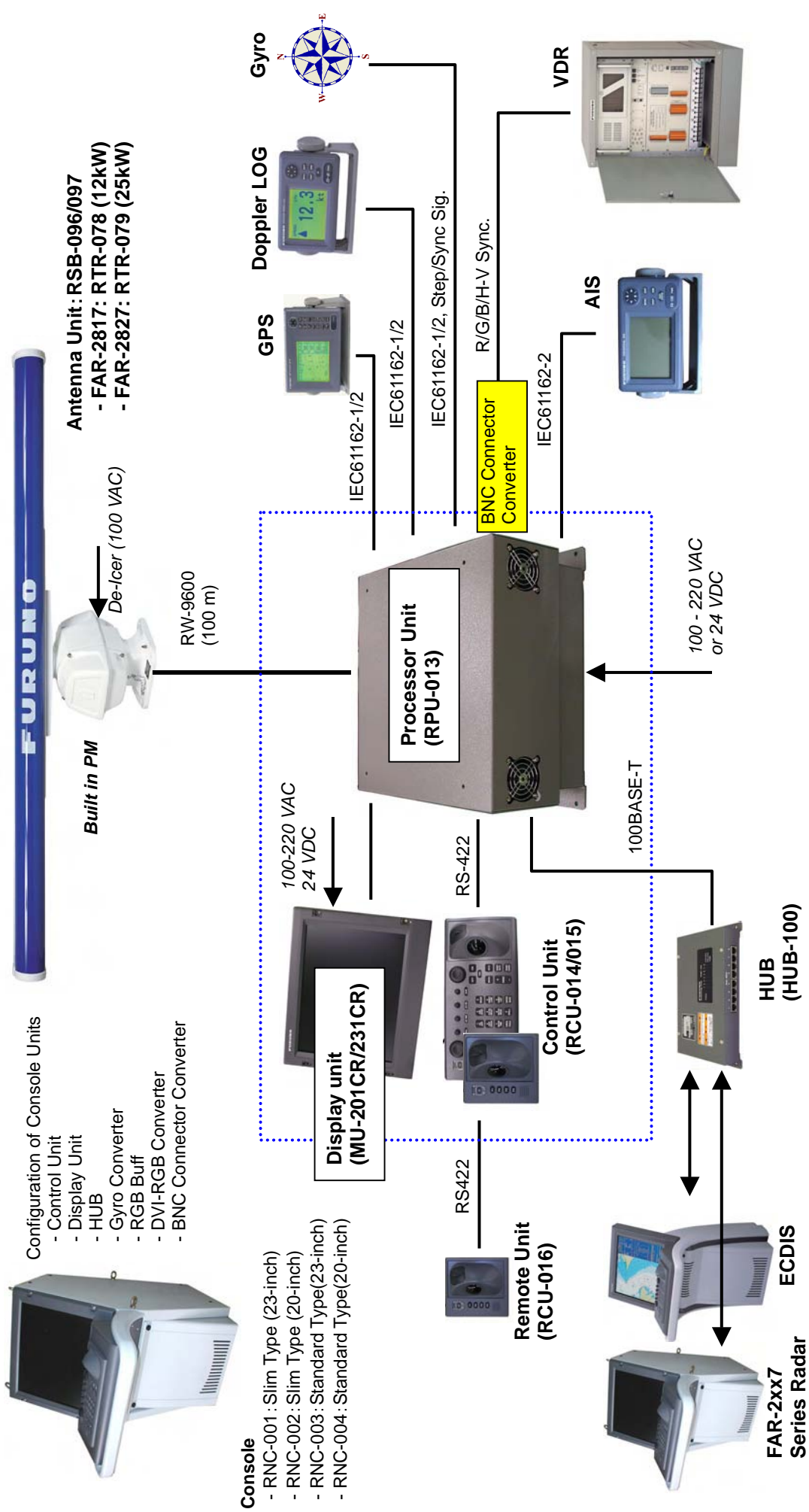

9. S-Band Radar: FAR-2837S (Two Unit Type)

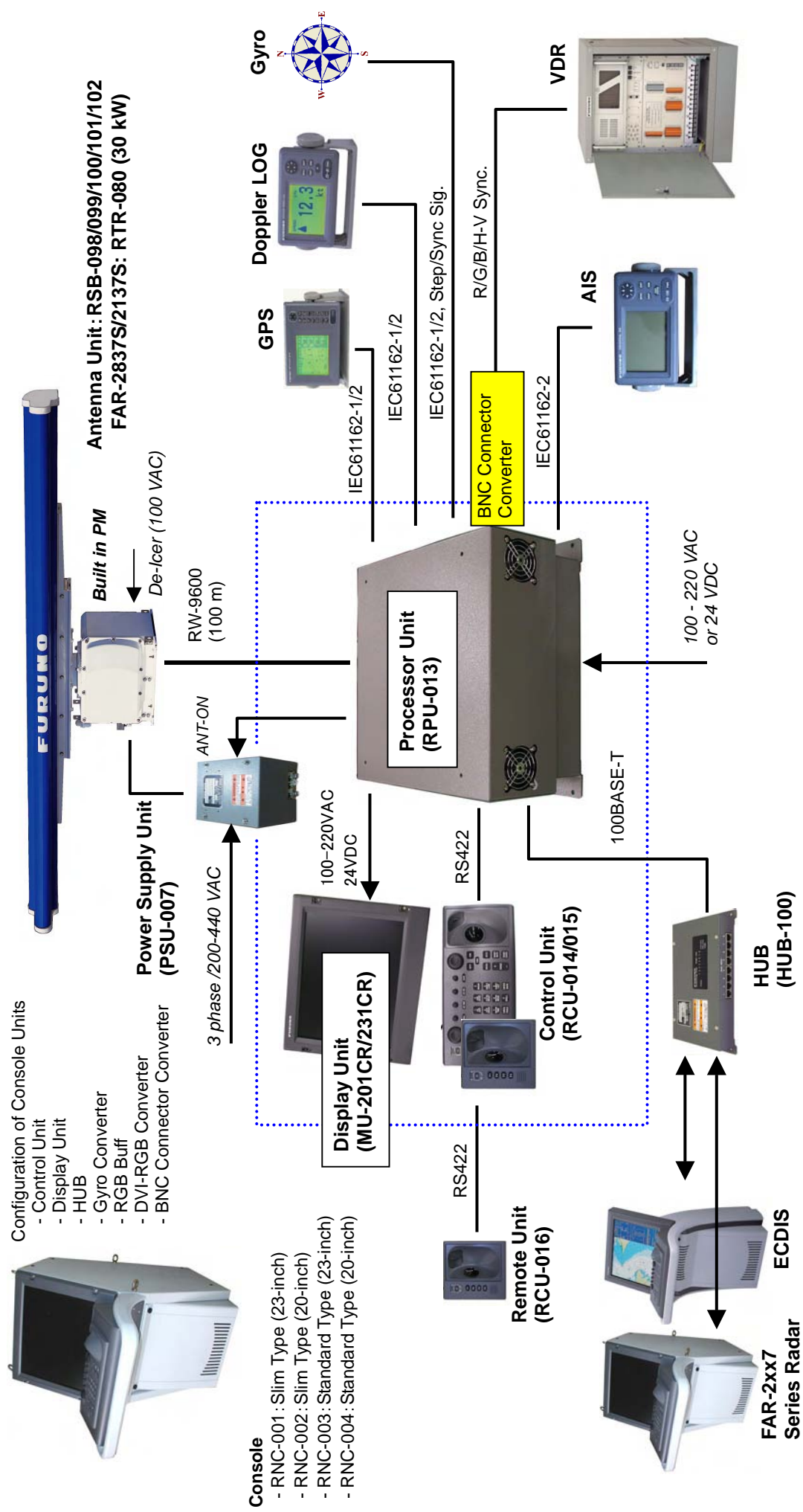

10. X-Band Radar: FAR-2827W (Tree Unit Type)

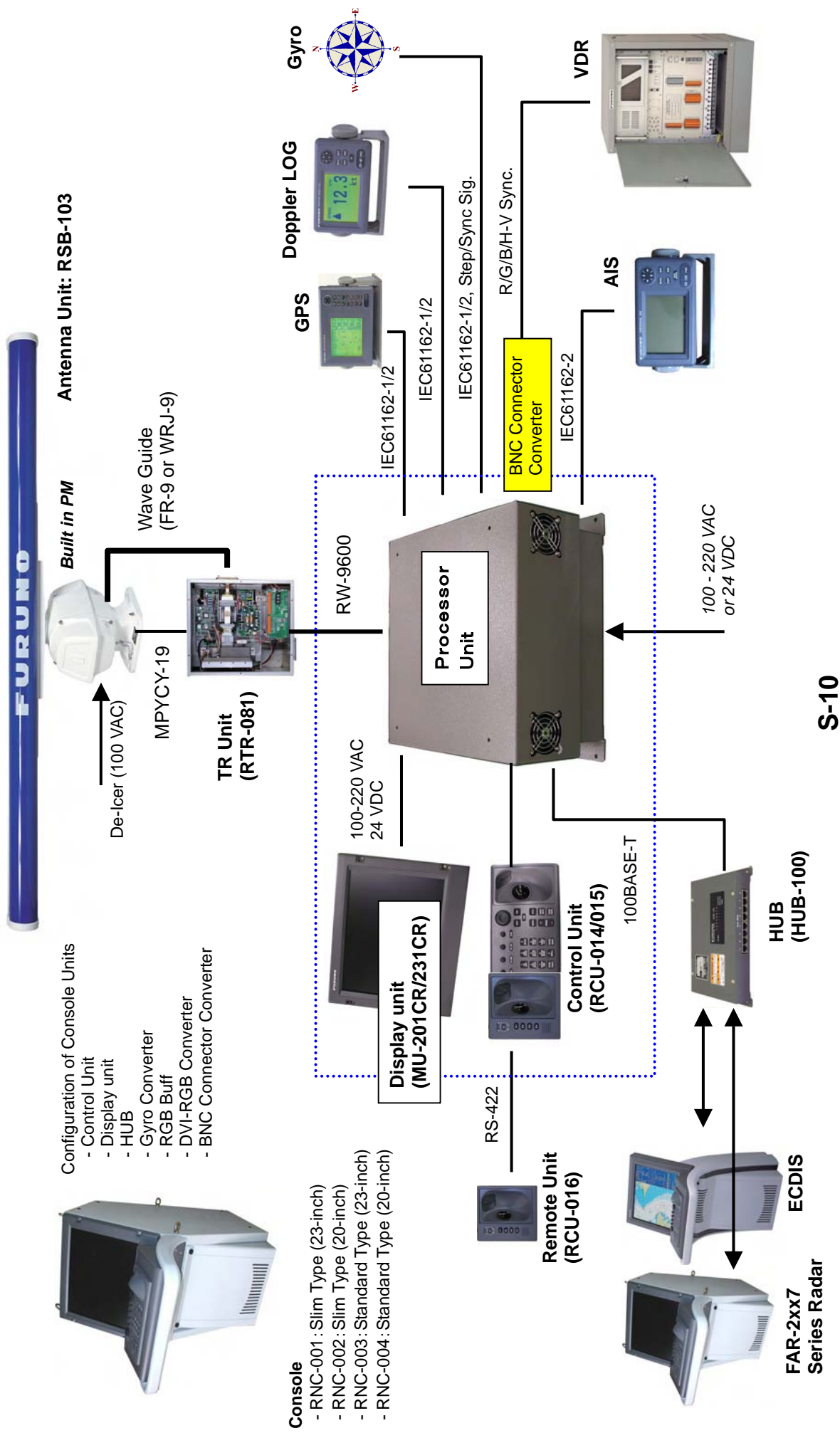

11. S-Band Radar: FAR-2837SW (Tree Unit Type)

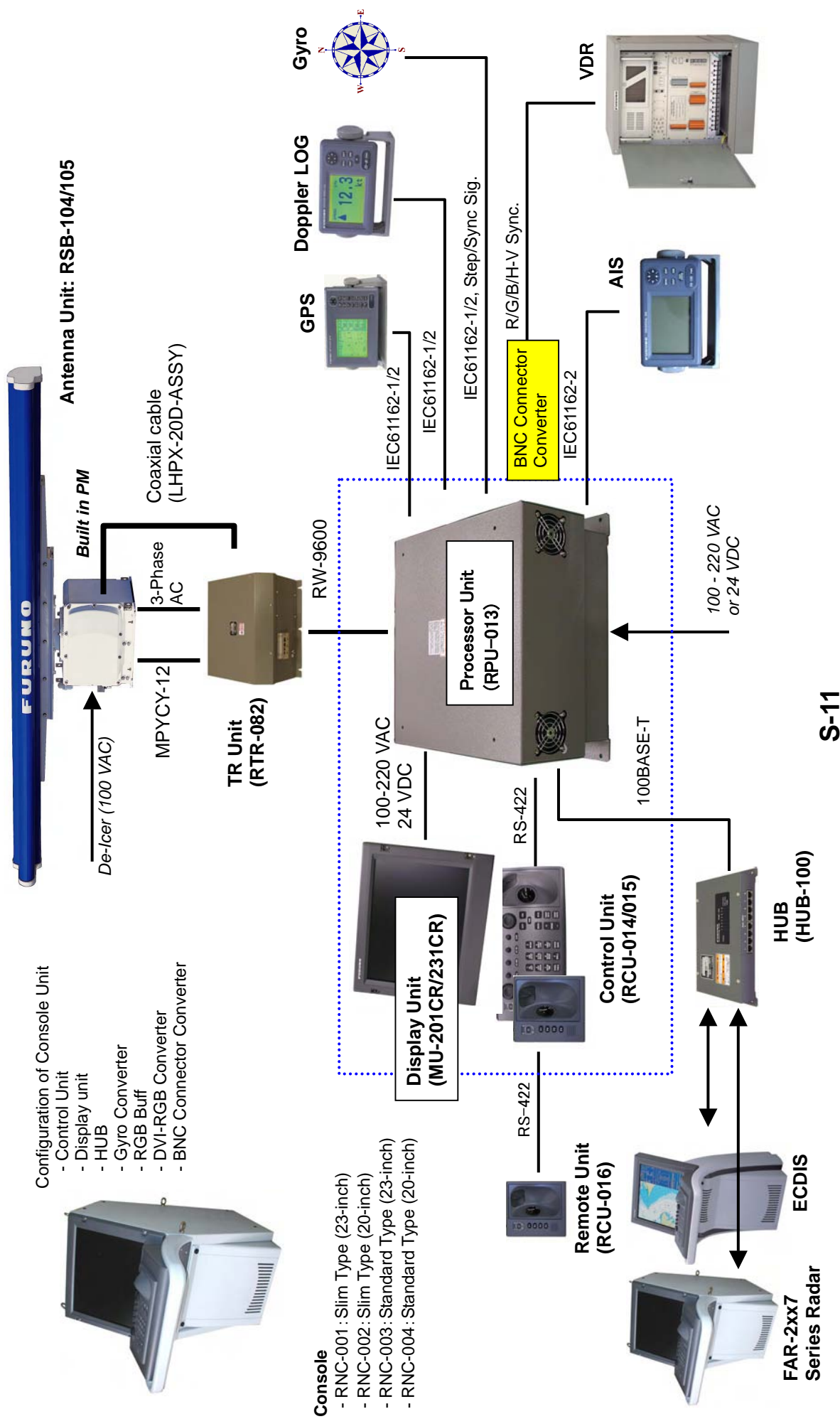

12. Radar/ECDIS Network Configuration

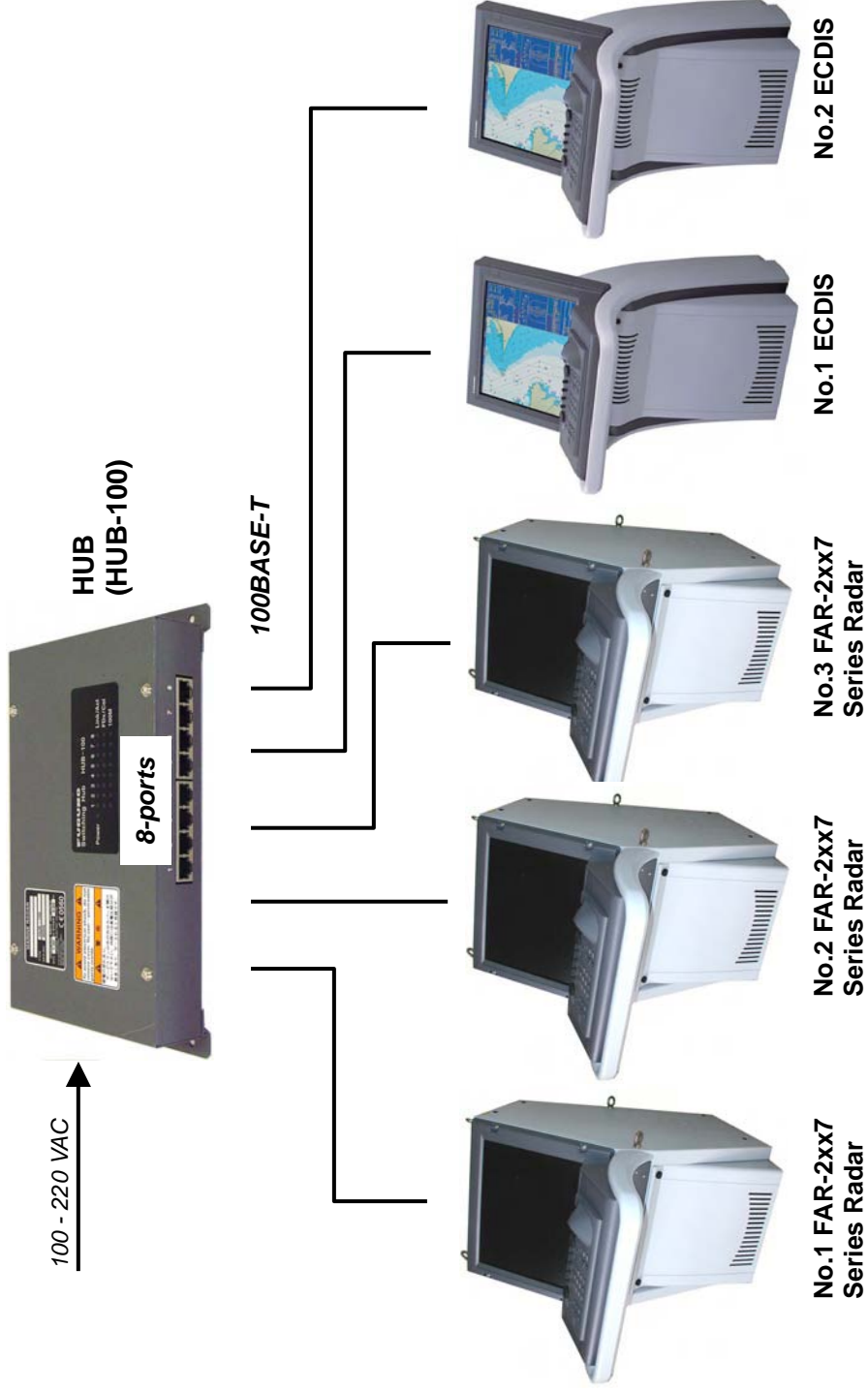

13. ECDIS: FEA-2107/2807

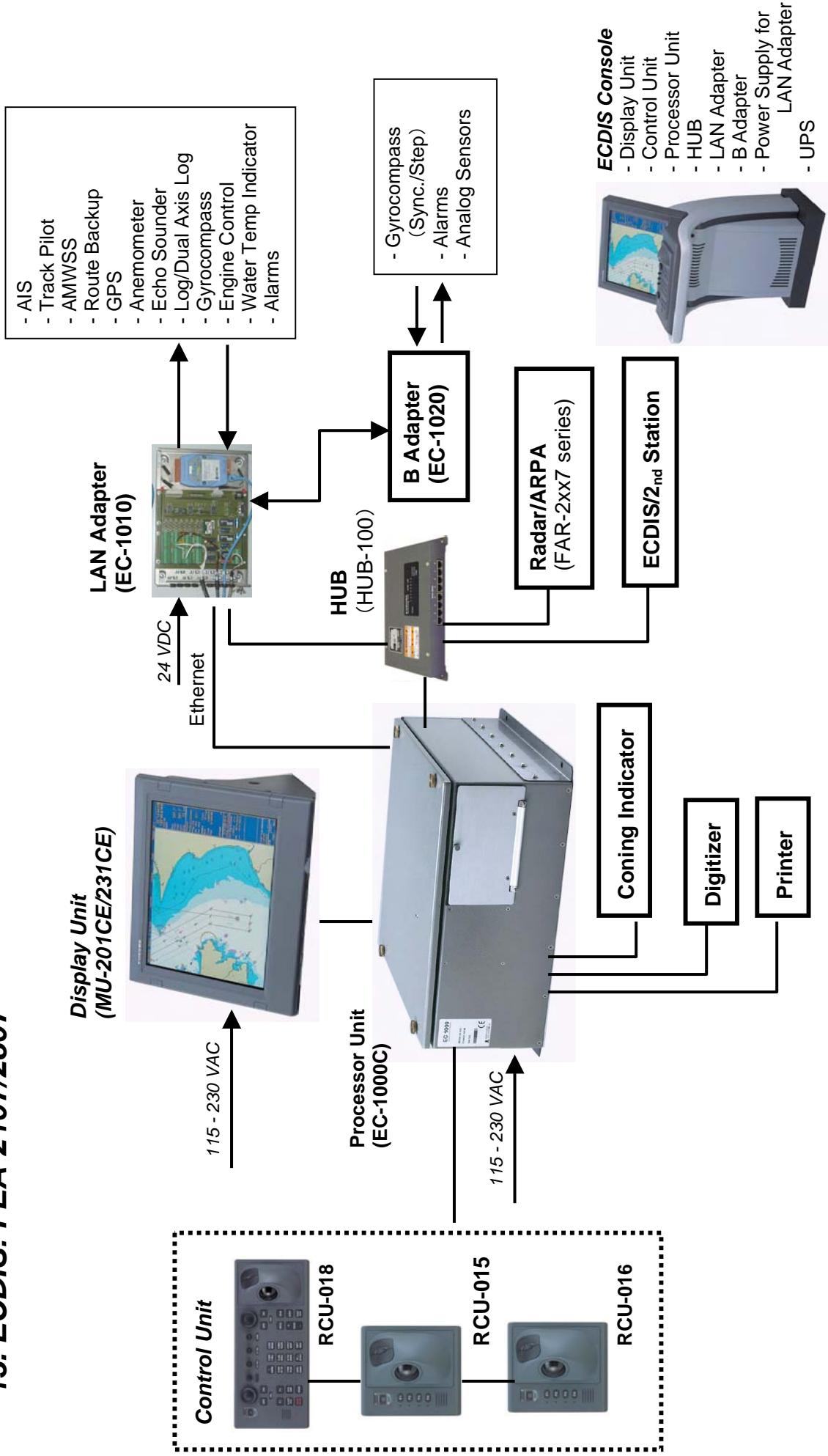

14. U-AIS: FA-150

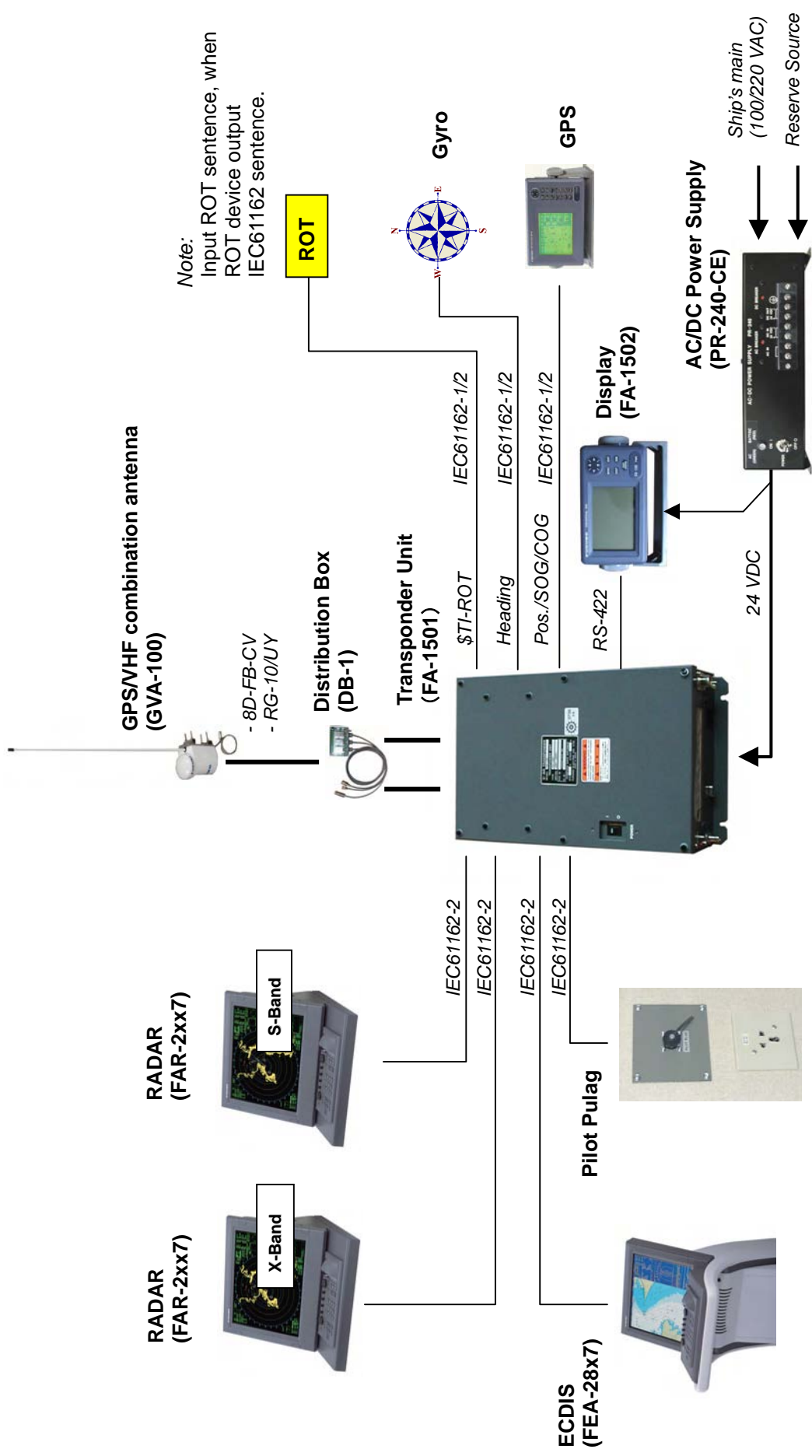

15. Weather FAX Receiver: FAX-210/214/215/410/30

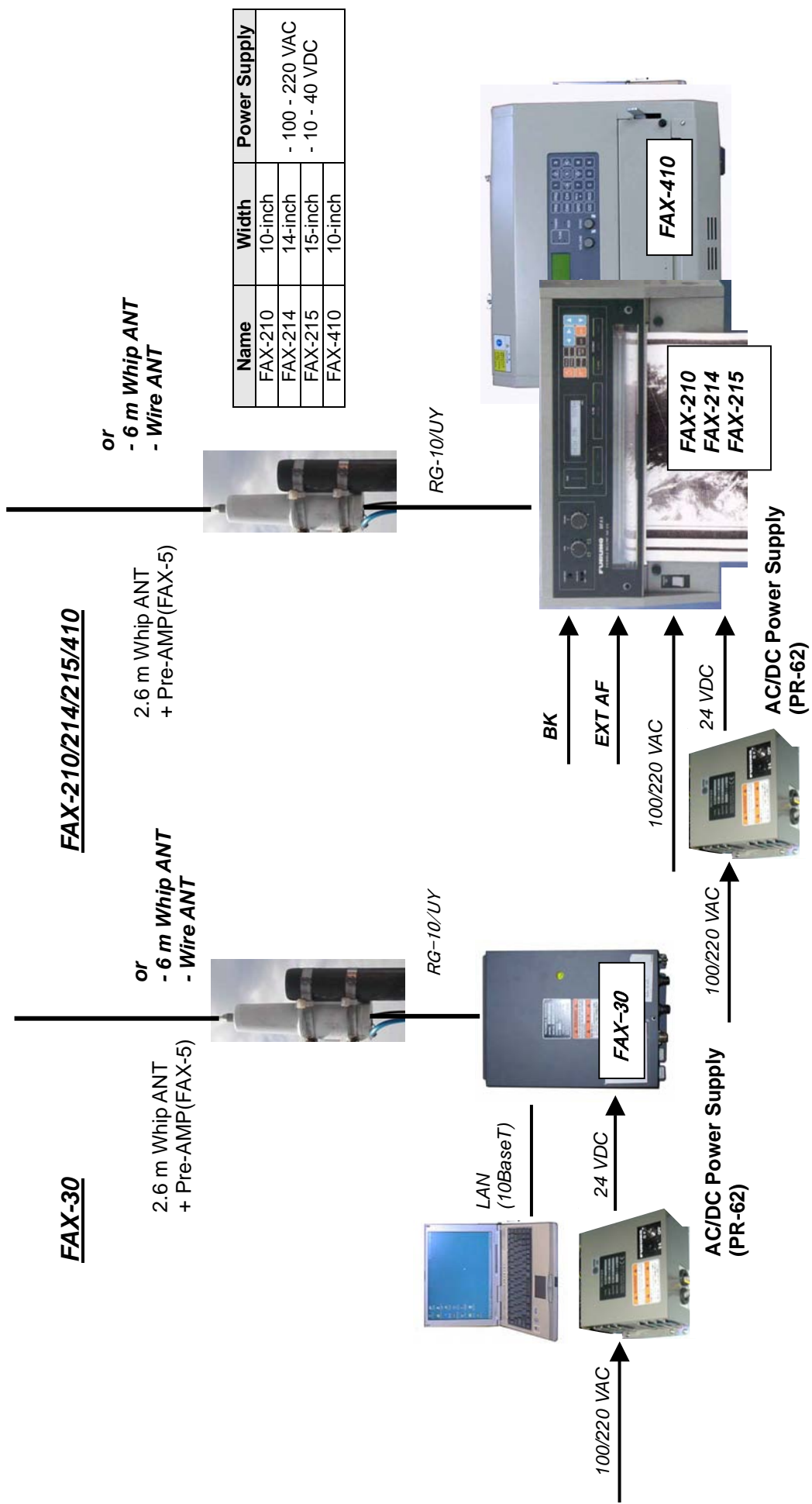

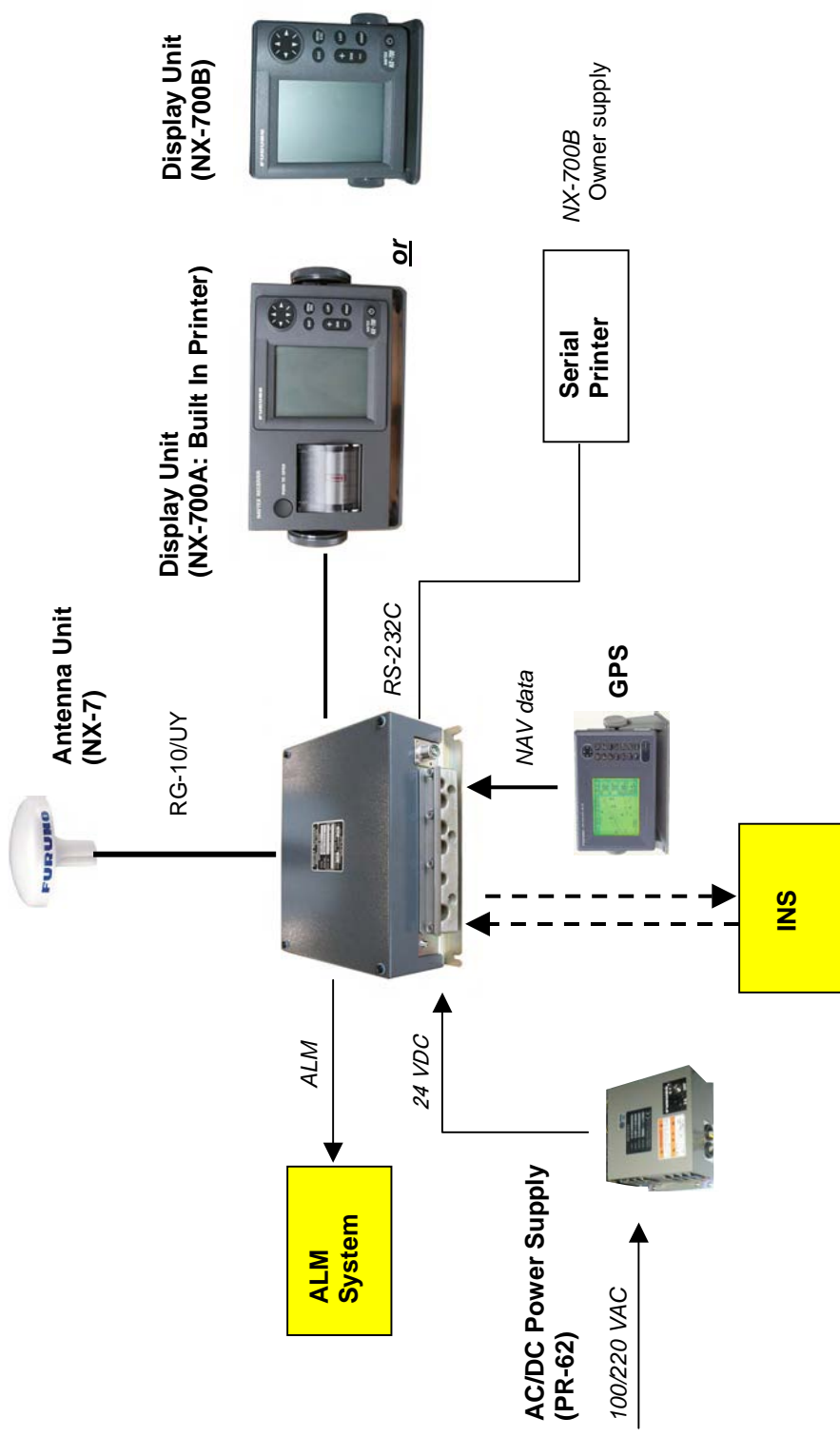
16. NAVTEX Receiver: NX-700A/B

17. VDR (Voyage Data Recorder): VR-5000

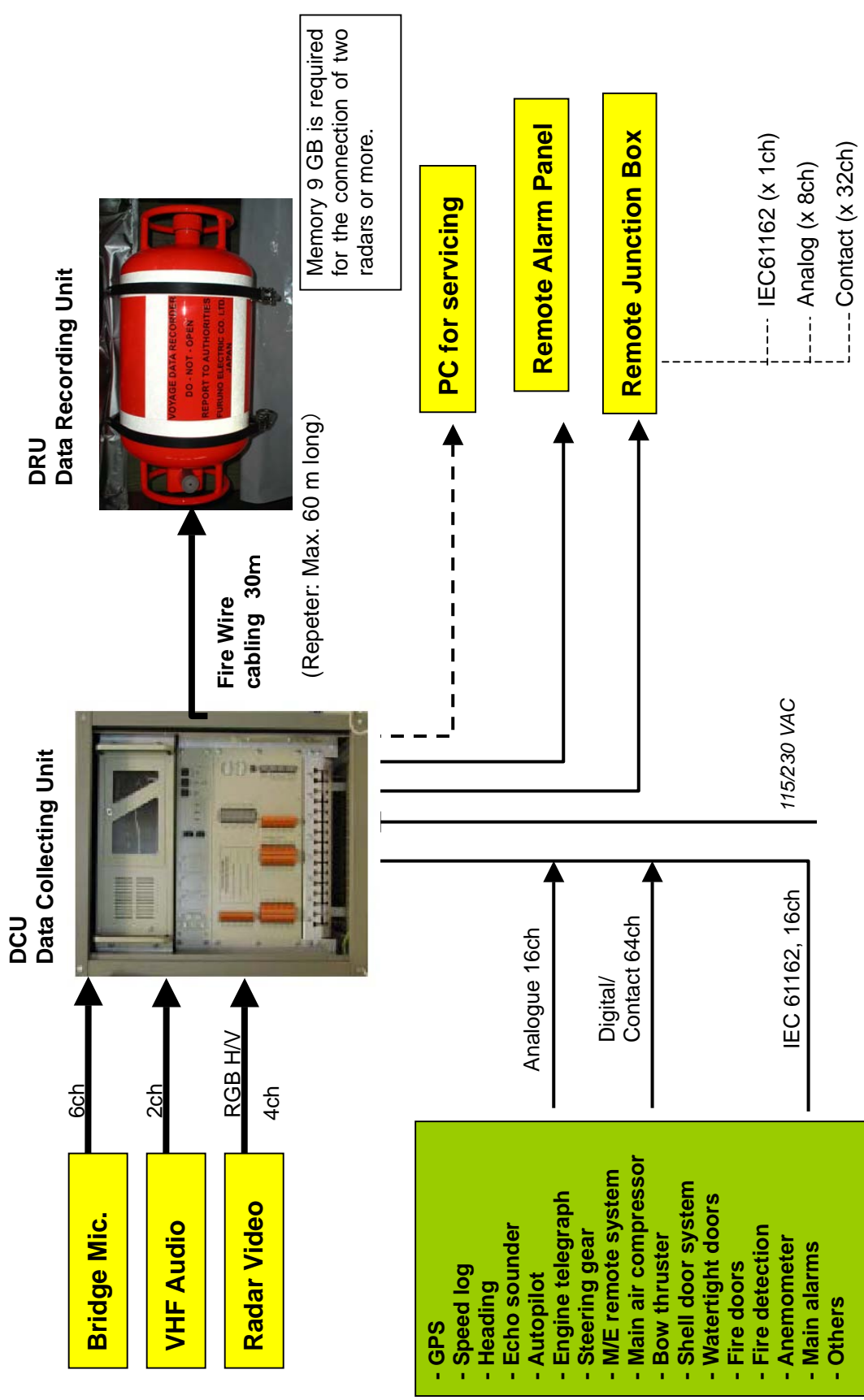

18. VDR (Voyage Data Recorder): VR-3000/3000S

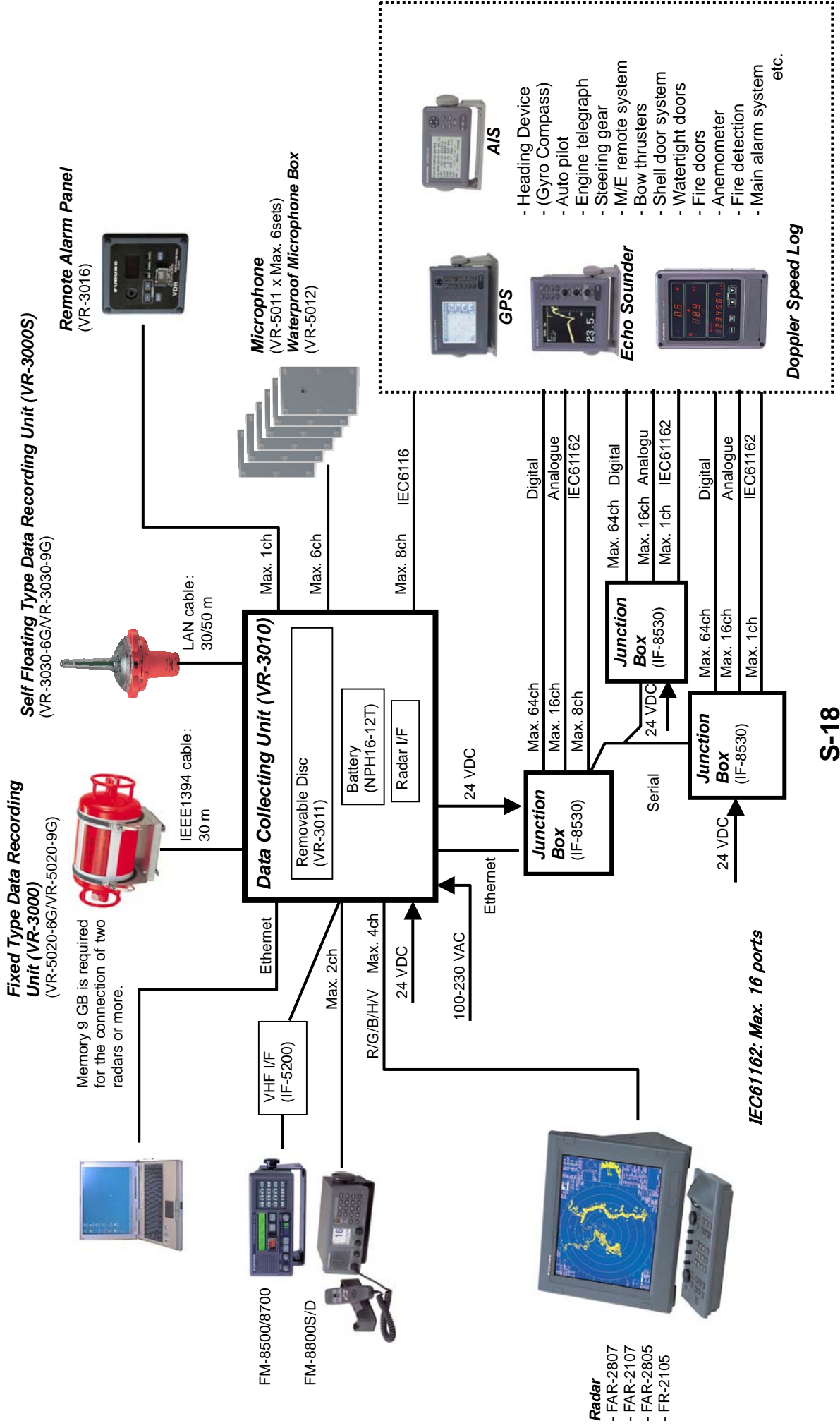

19. Doppler Speed Log: DS-80

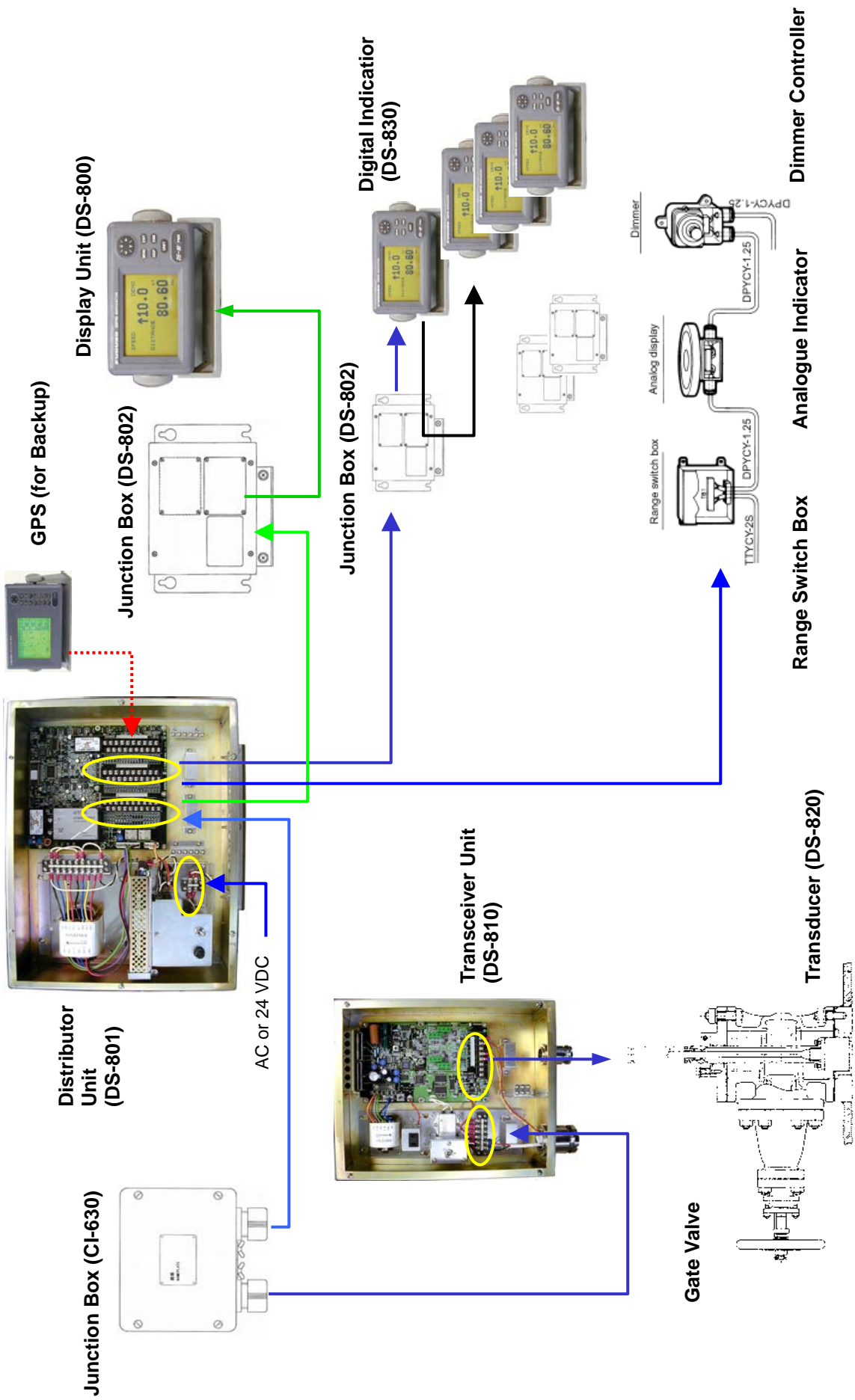

20. Doppler Speed Log: DS-50

Processor and Transceiver Units Separate Type

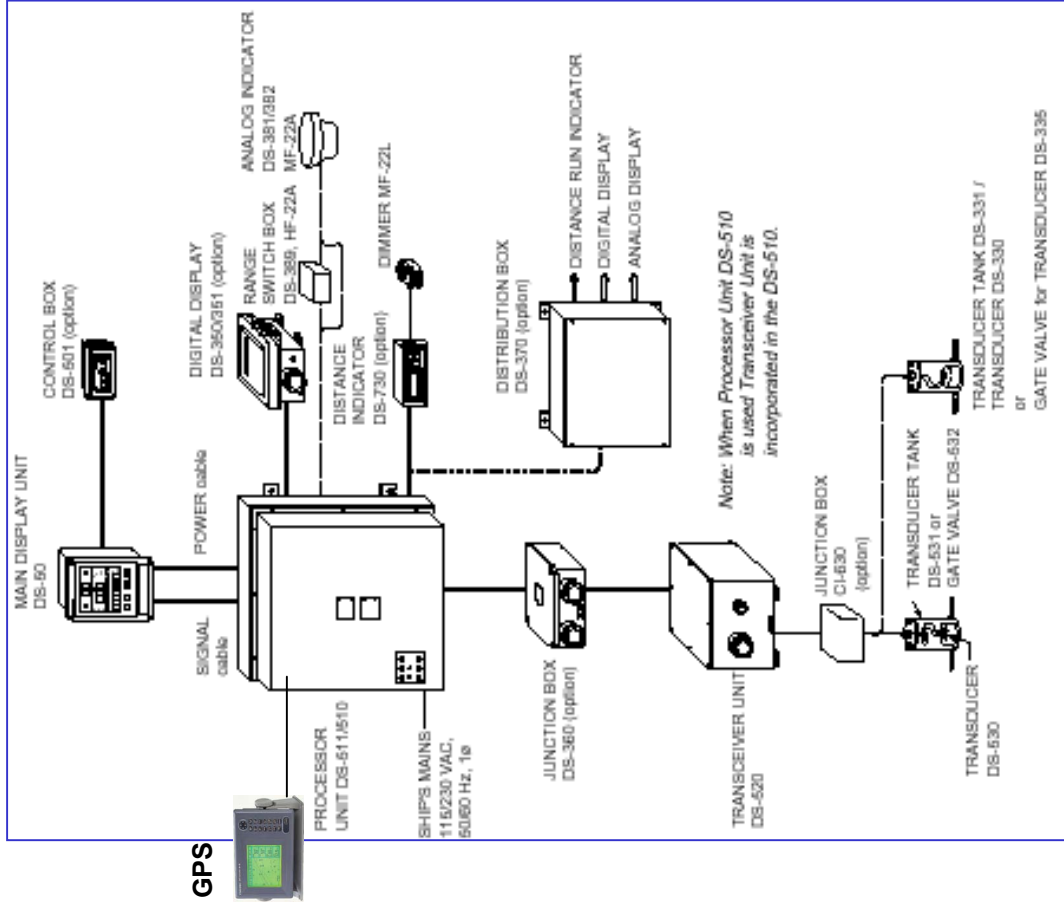

Processor and Transceiver Units Combination Type

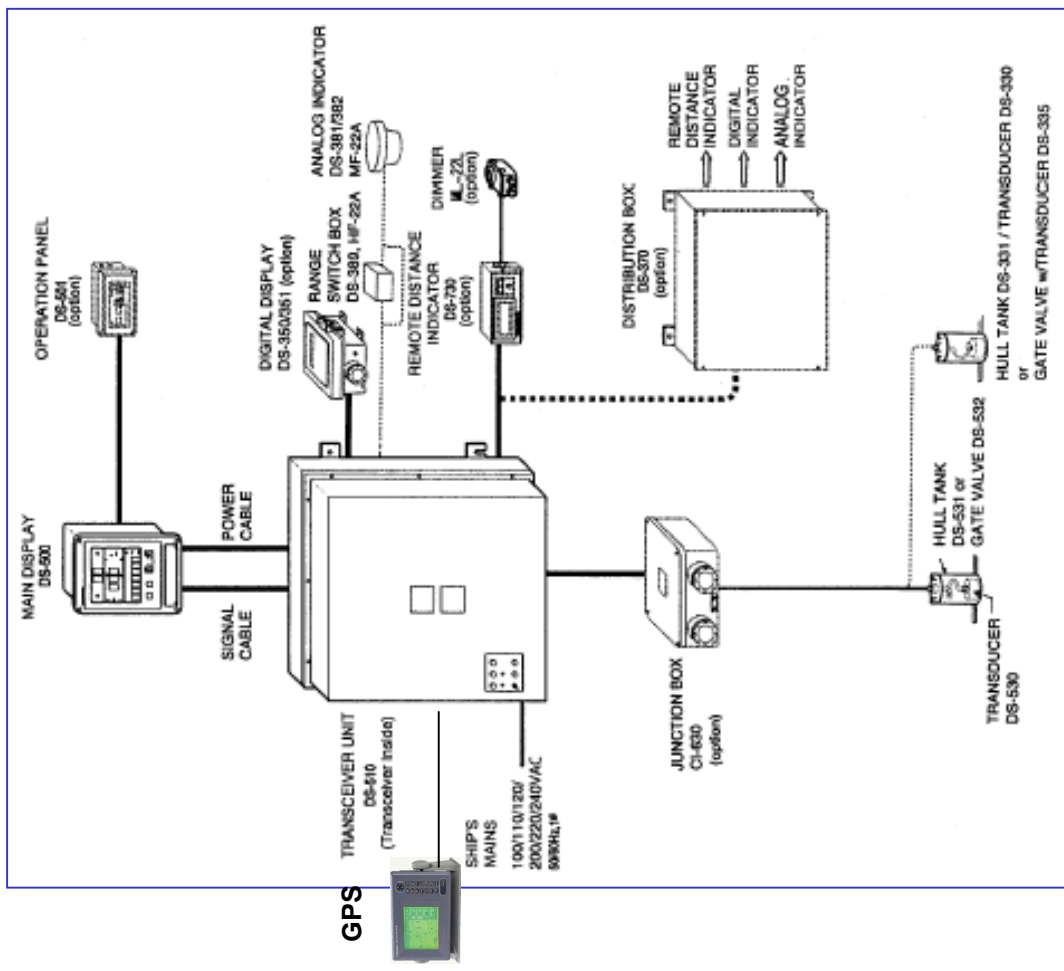

22. Doppler Speed Log: DS-30

Connections between Processor unit and Distribution box.

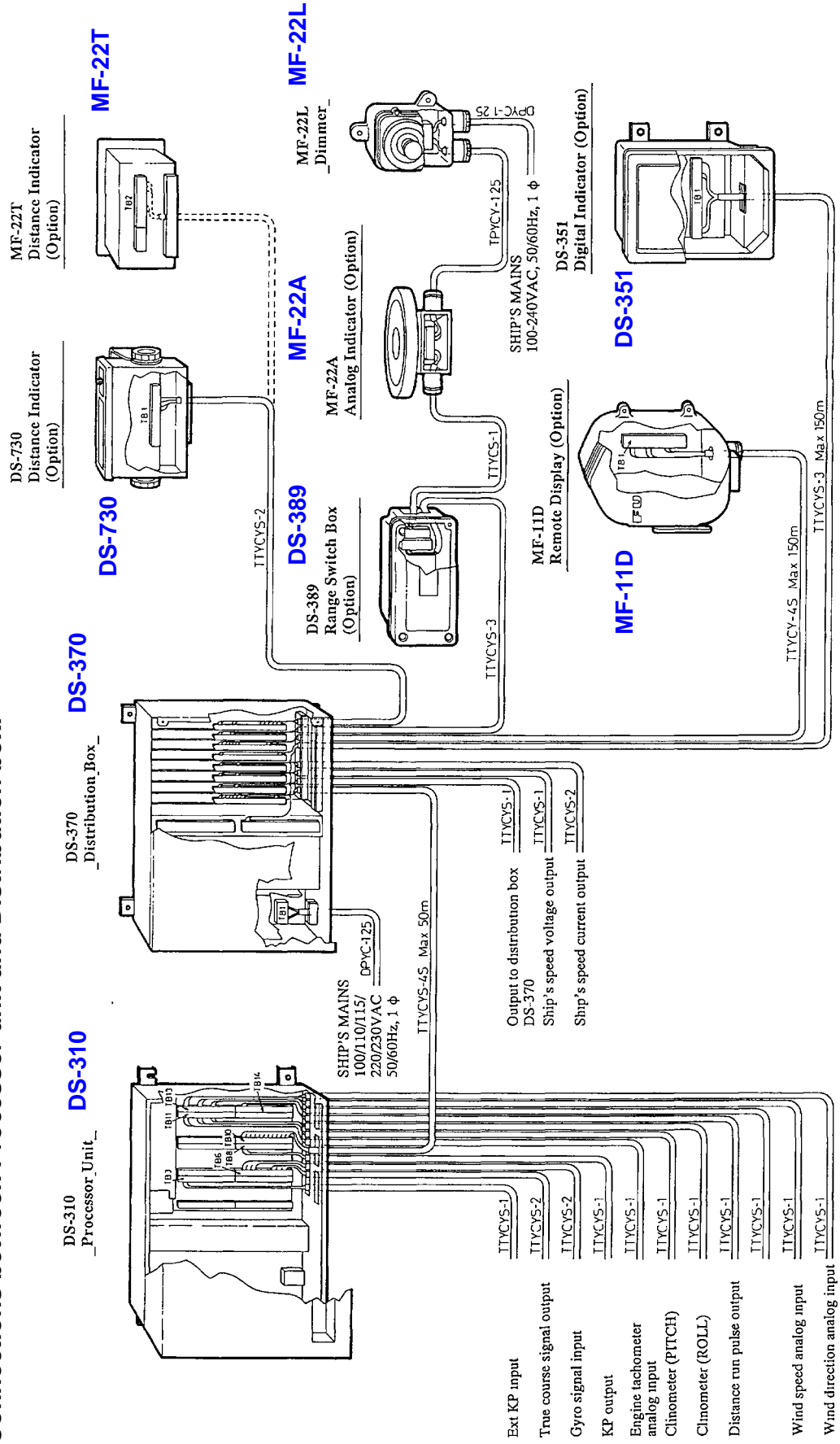

23. Navigational Echo Sounder: FE-700

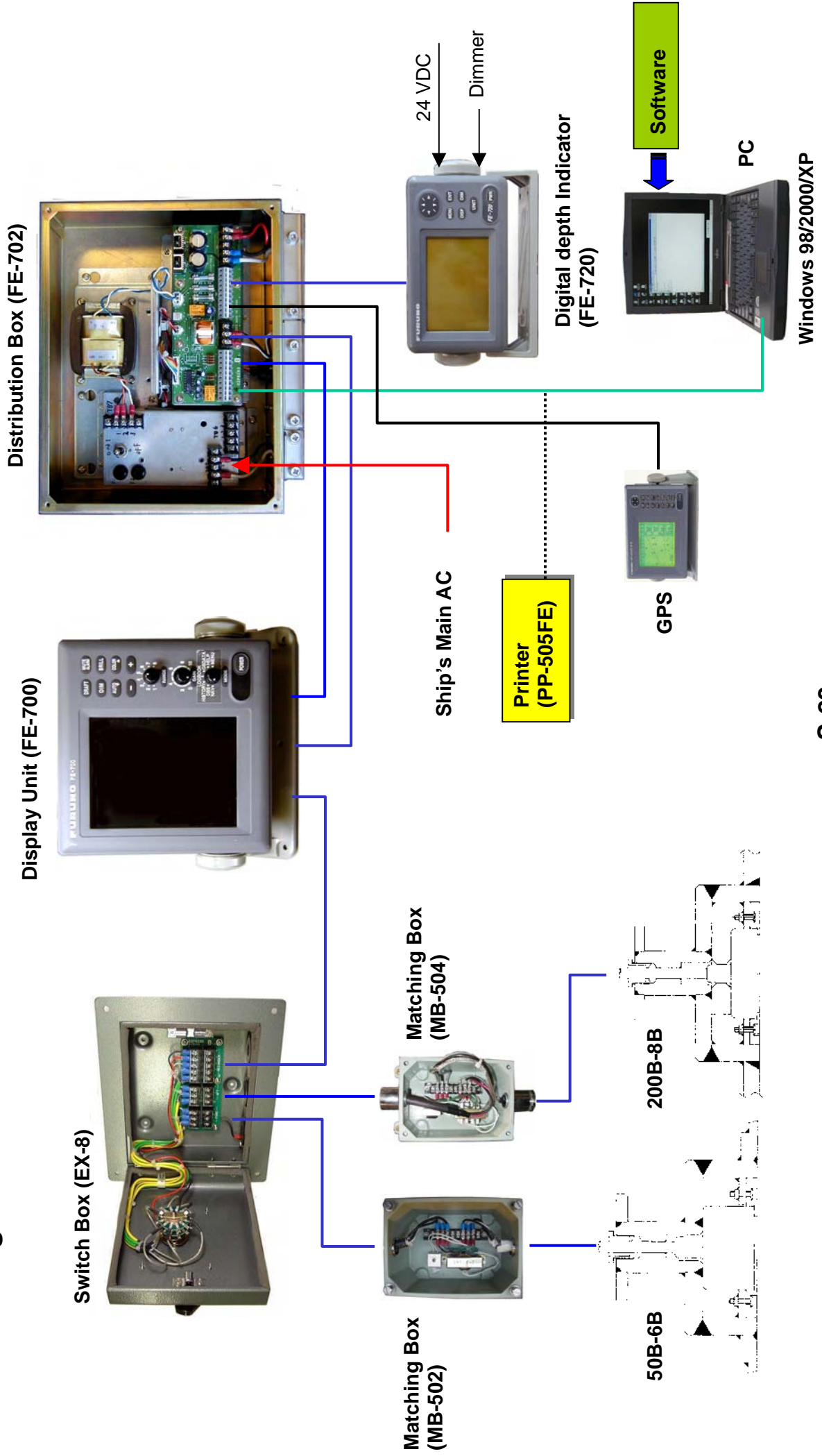

24. Navigational Echo Sounder: FE-700

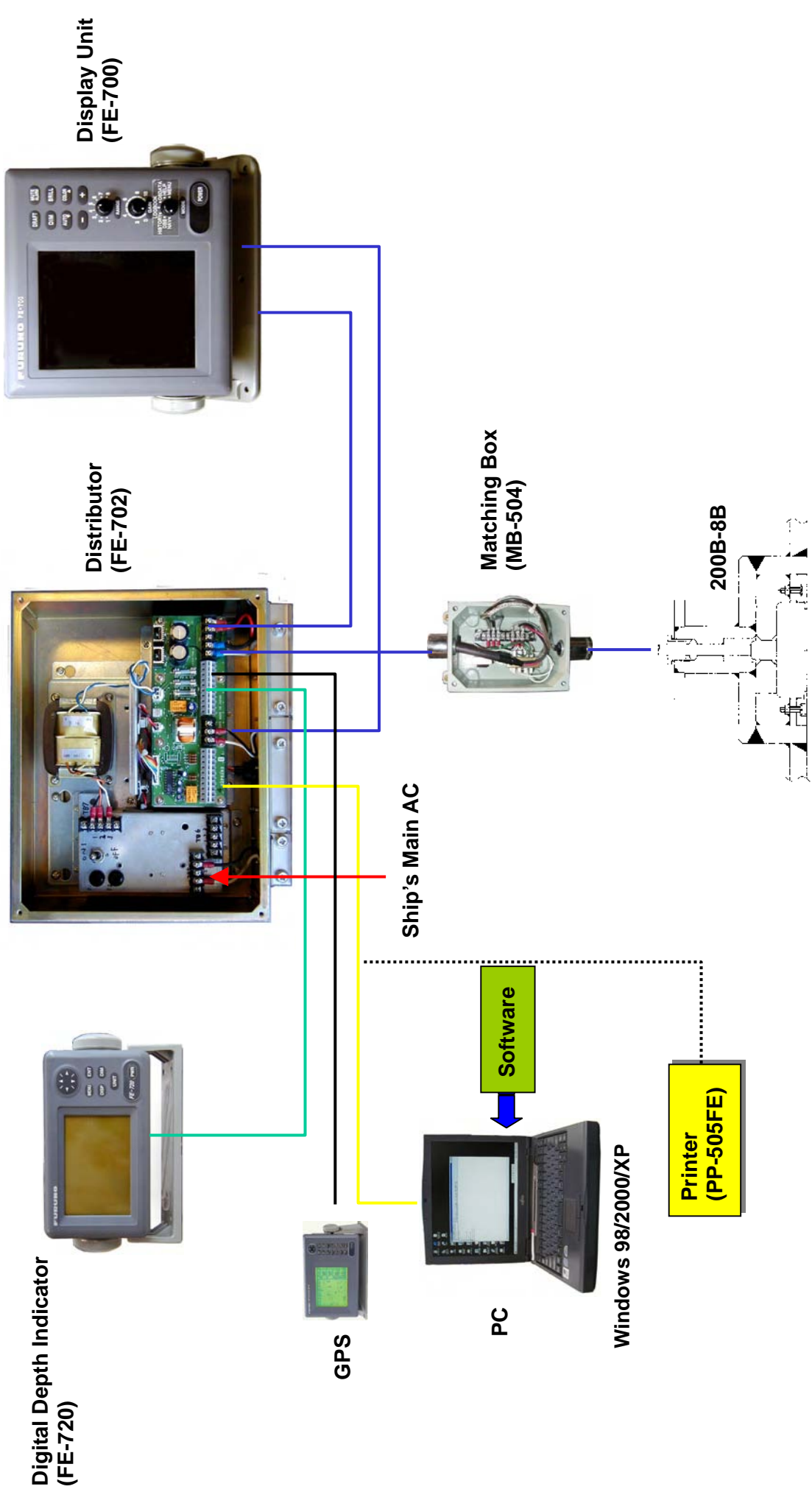

This page is intentionally left blank.

Part-2

Installation

<i>Chapter 1. Radar</i>	<i>FAR-2107/2807 series</i>
<i>Chapter 2. ECDIS</i>	<i>FEA-2107/2807 series</i>
<i>Chapter 3. MF/HF Radio</i>	<i>RC-1800</i>
<i>Chapter 4. VHF Radio</i>	<i>FM-8800S/D</i>
<i>Chapter 5. INMARSAT</i>	<i>FELCOM 82/15/16/70</i>
<i>Chapter 6. NAVTEX/FAX</i>	<i>NX-700A/B, FAX-215/410</i>
<i>Chapter 7. GPS</i>	<i>GP-90</i>
<i>Chapter 8. U-AIS</i>	<i>FA-150</i>
<i>Chapter 9. VDR</i>	<i>VR-5000/3000</i>
<i>Chapter 10. Life-saving Appliance</i>	<i>TBR-600/FM-8/KANNAD-406PRO</i>
<i>Chapter 11. Navigational Echo Sounder</i>	<i>FE-700</i>
<i>Chapter 12. Doppler Sonar</i>	<i>DS-30/50/80</i>
<i>Appendix 1. Acoustic Equipment</i>	
<i>Appendix 2. Antenna Installation</i>	
<i>Appendix 3. Radar Waveguide</i>	
<i>Appendix 4. Cables</i>	
<i>Appendix 5. Basic Skill</i>	

1.1 Arrangement of Antenna Mast

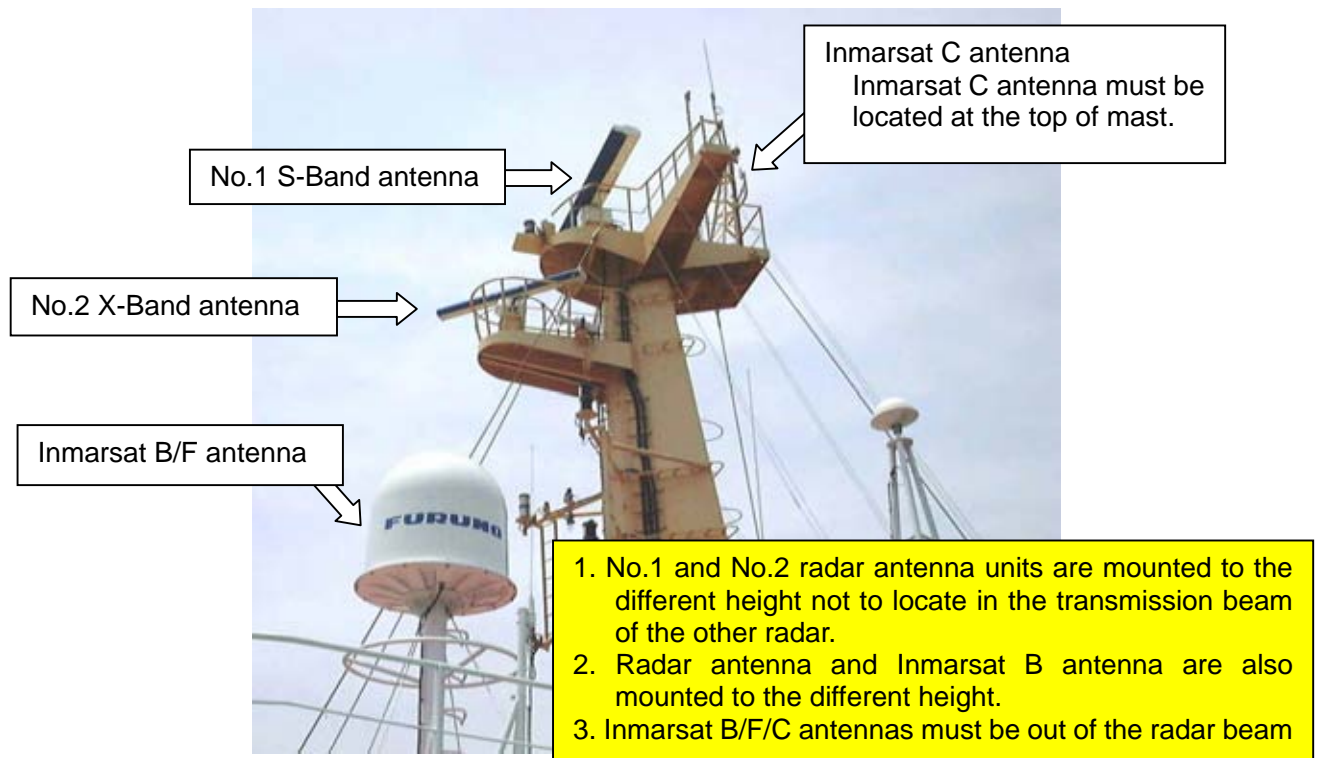

Fig. 1.1.1 Radar antenna Mast-1

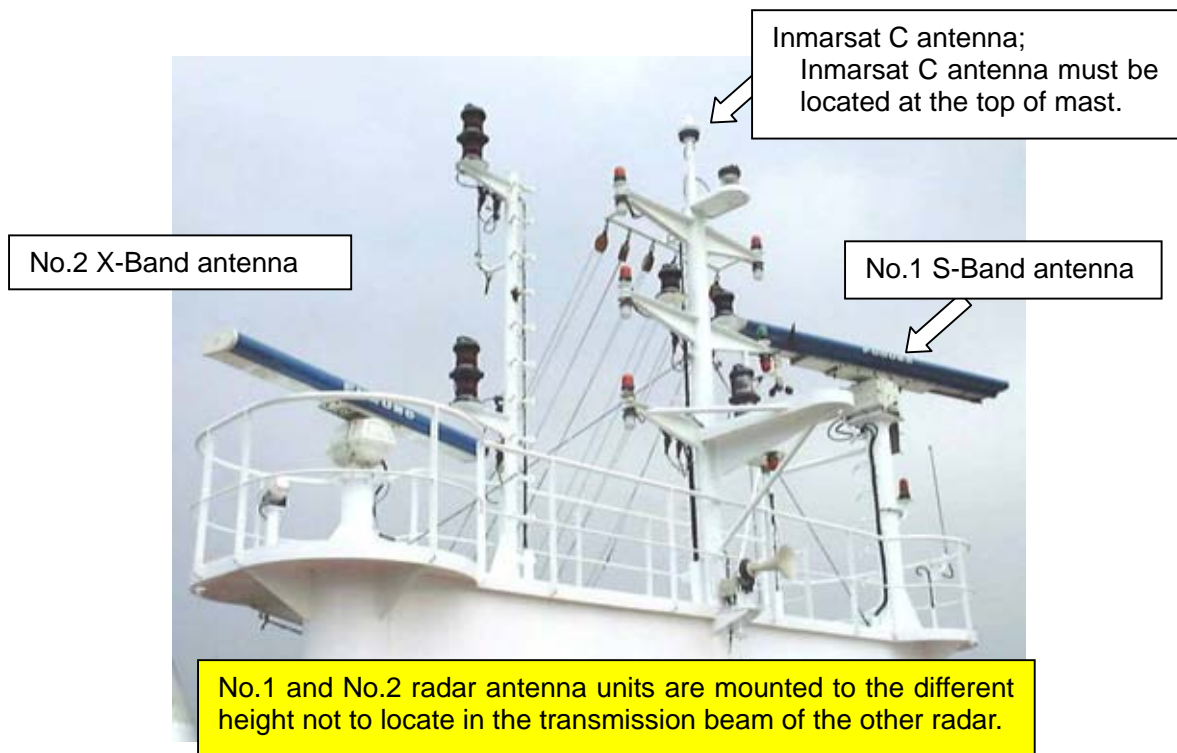

Fig. 1.1.2 Radar antenna Mast-2

1.2 Installation of X-Band Radar

1.2.1 General Mounting of Radar antenna

the performance monitor antenna should be Installed to the stern direction of Rader antenna unit.

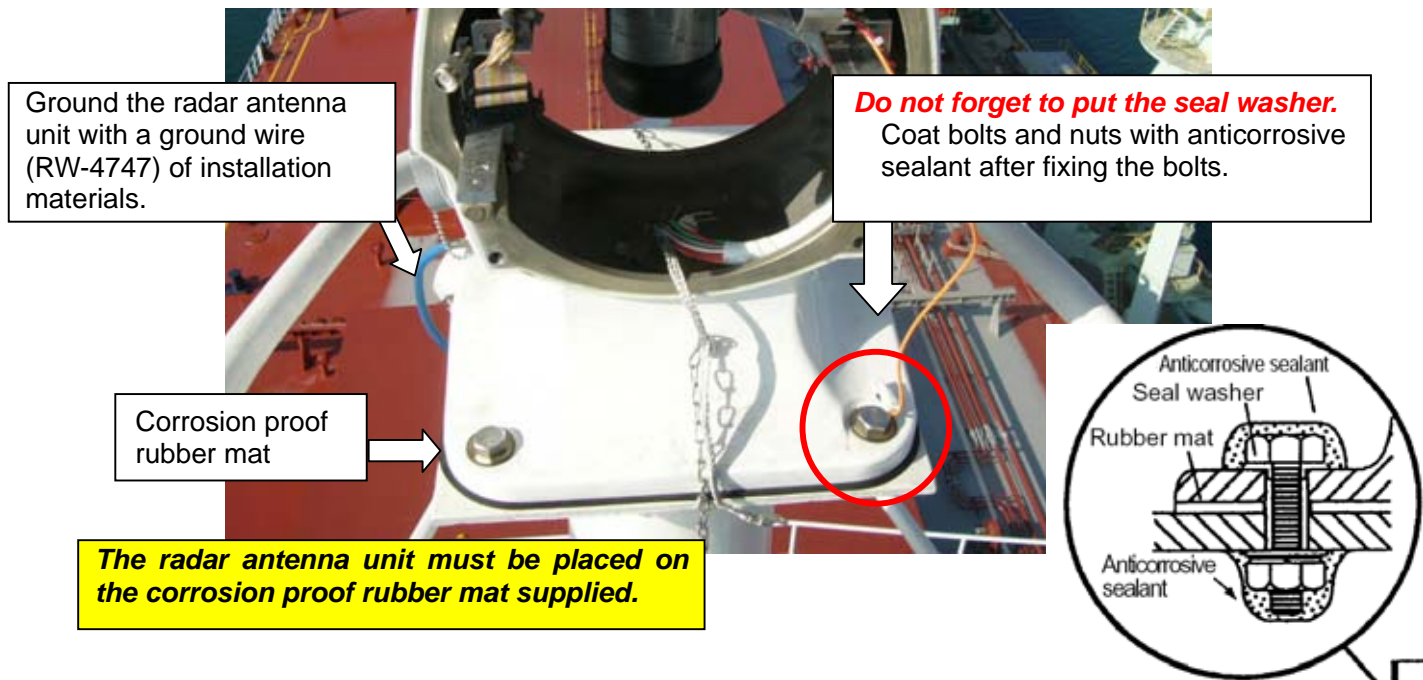

Fig. 1.2.1 Mounting of radar antenna unit

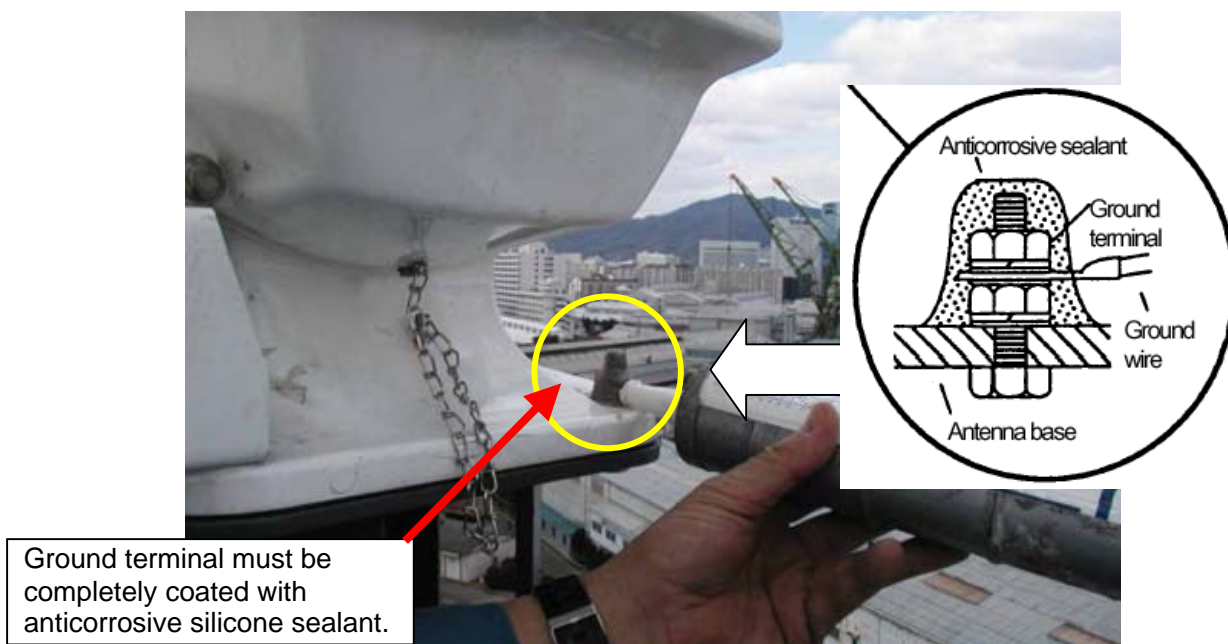

Fig. 1.2.2 Ground terminal

1.2.2 Equipping the performance monitor: PM for X-Band Radar

Performance monitor unit is incorporated in the radar antenna unit.

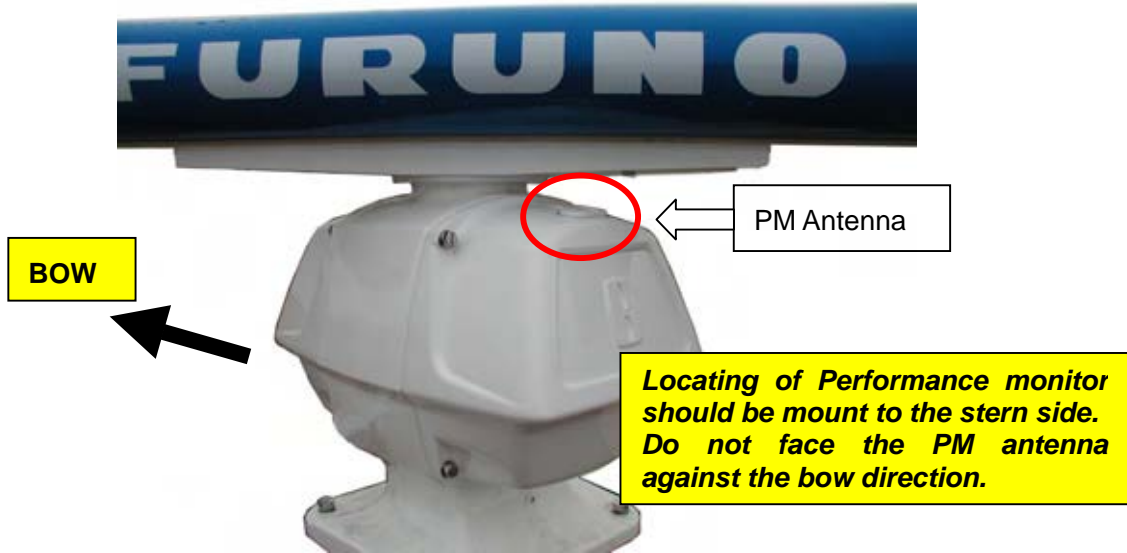

Fig. 1.2.3 PM antenna

Confirm that the packing is fitted in the groove before fixing the antenna cover.



Fig. 1.2.4 PM unit

1.2.3 Mounting of X-Band Radar: TR-UP Type antenna

Antenna mounting base

Make cable entrance and fixing holes on the antenna-mounting base.
Fabricating the signal cable as shown the below.

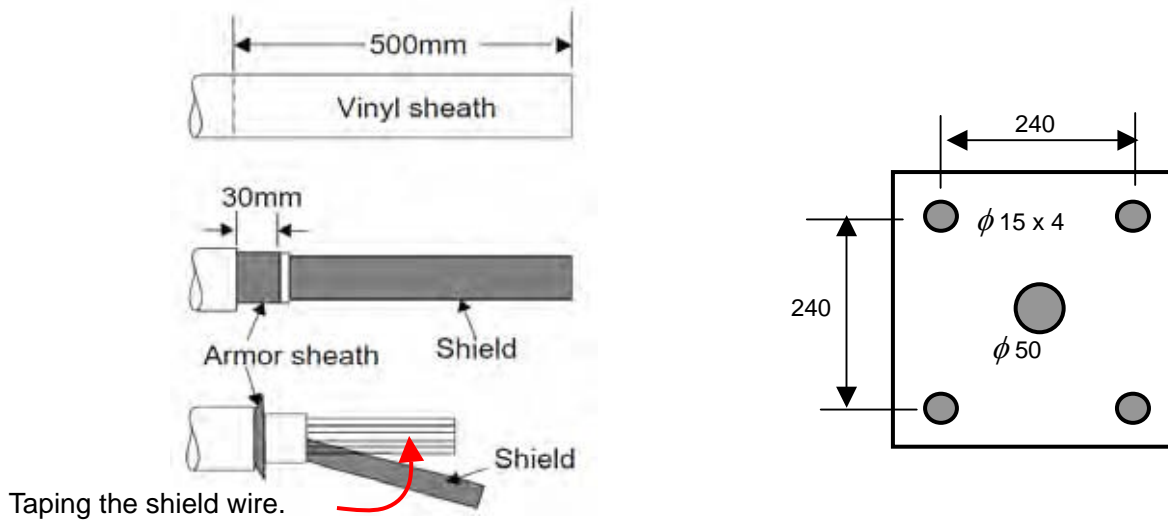

Fig. 1.2.5 Antenna mounting base and fabricating the signal cable

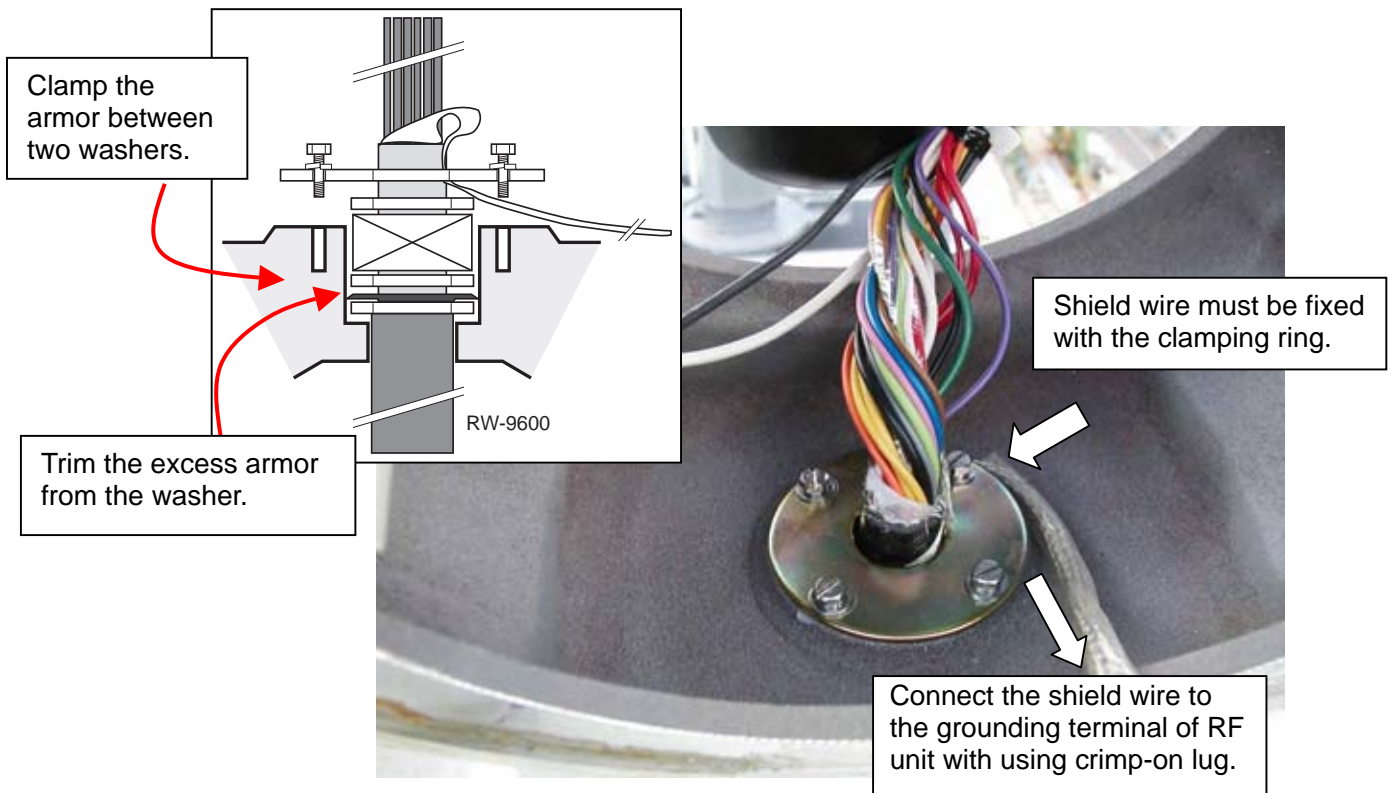
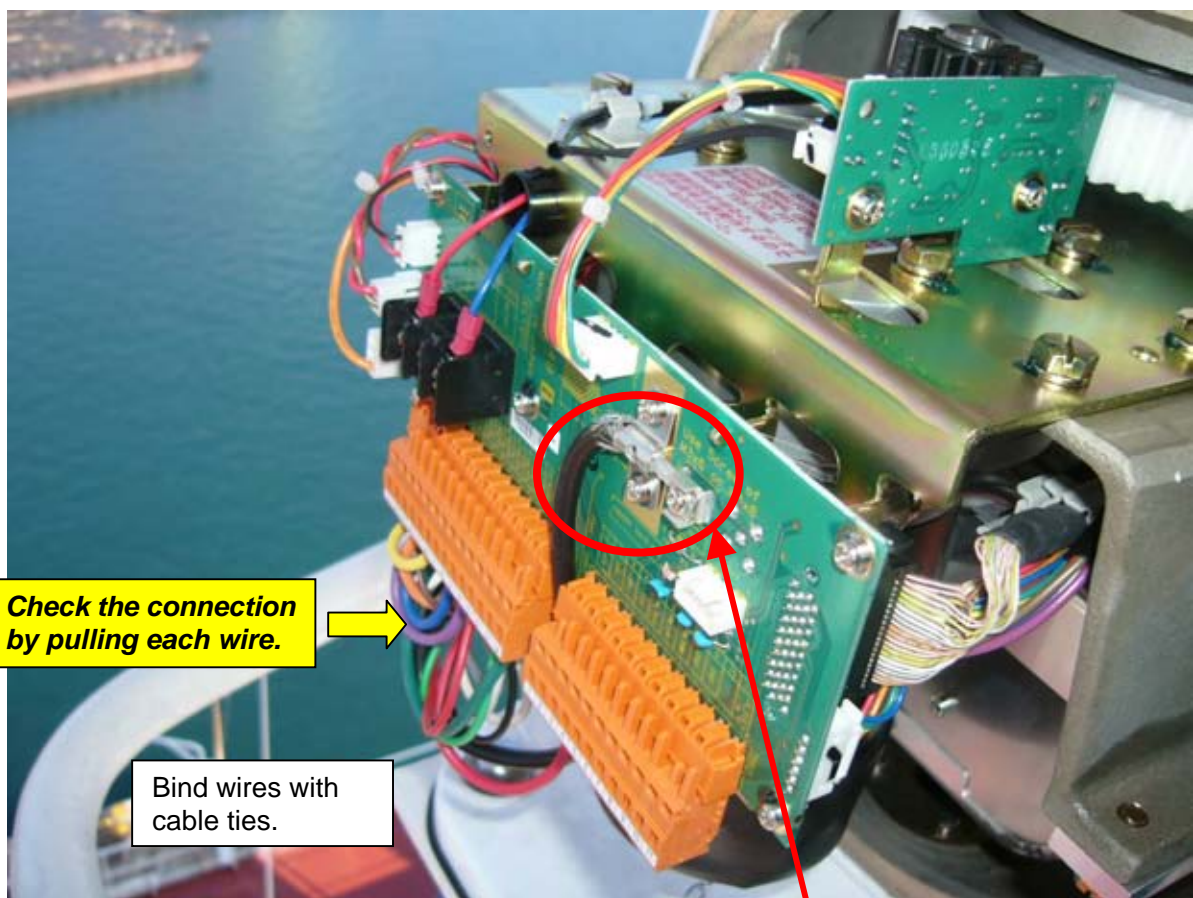
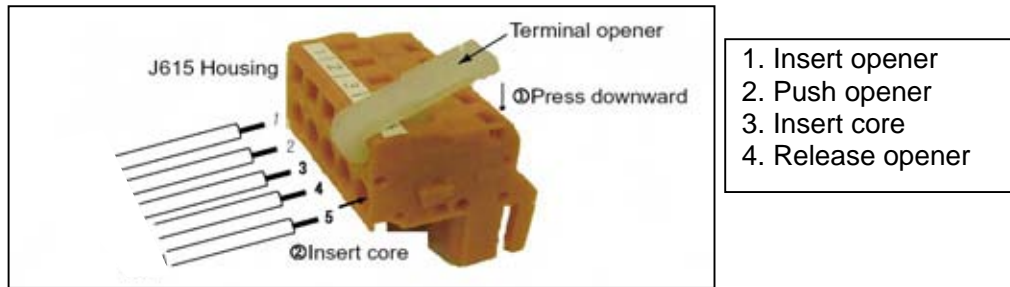

Fig. 1.2.6 Cable entrance of radar antenna unit

Make connections correctly and bind cables with cable ties properly.



Fold back shield, and fix the shield with clamping bracket. Fix the conductor by the metal plate securely and directly.

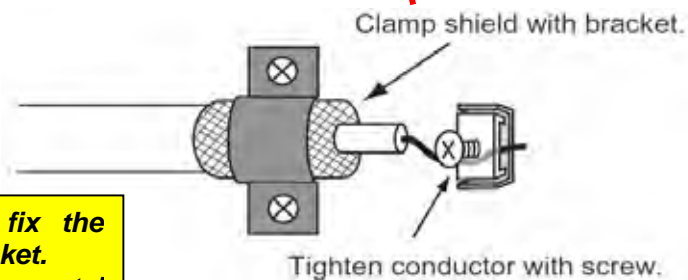

Fig. 1.2.7 Wiring of cable PW9600

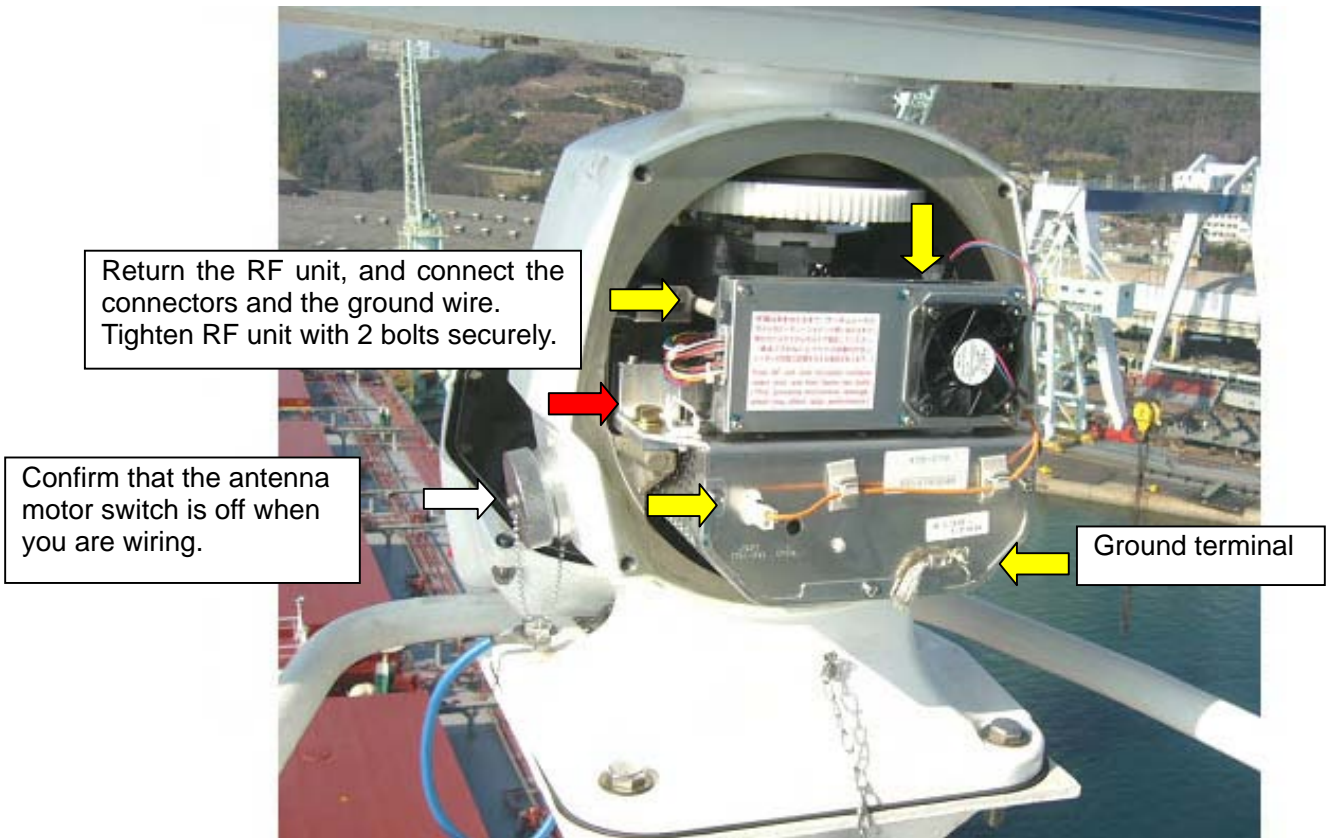

Fig. 1.2.8 Fixing the RF unit



Fig. 1.2.9 Fixing antenna cover

1.2.4 Mounting of X-Band Radar: TR-DOWN type antenna

Insert the signal cable: MPYC-19 through the cable gland at the antenna unit side, and fabricate as shown below.

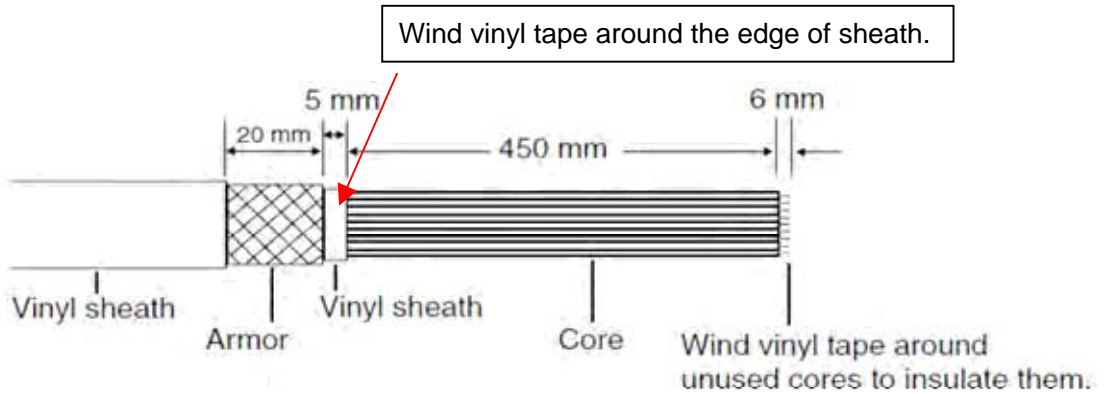

Fig.1.2.10 Fabricating signal cable

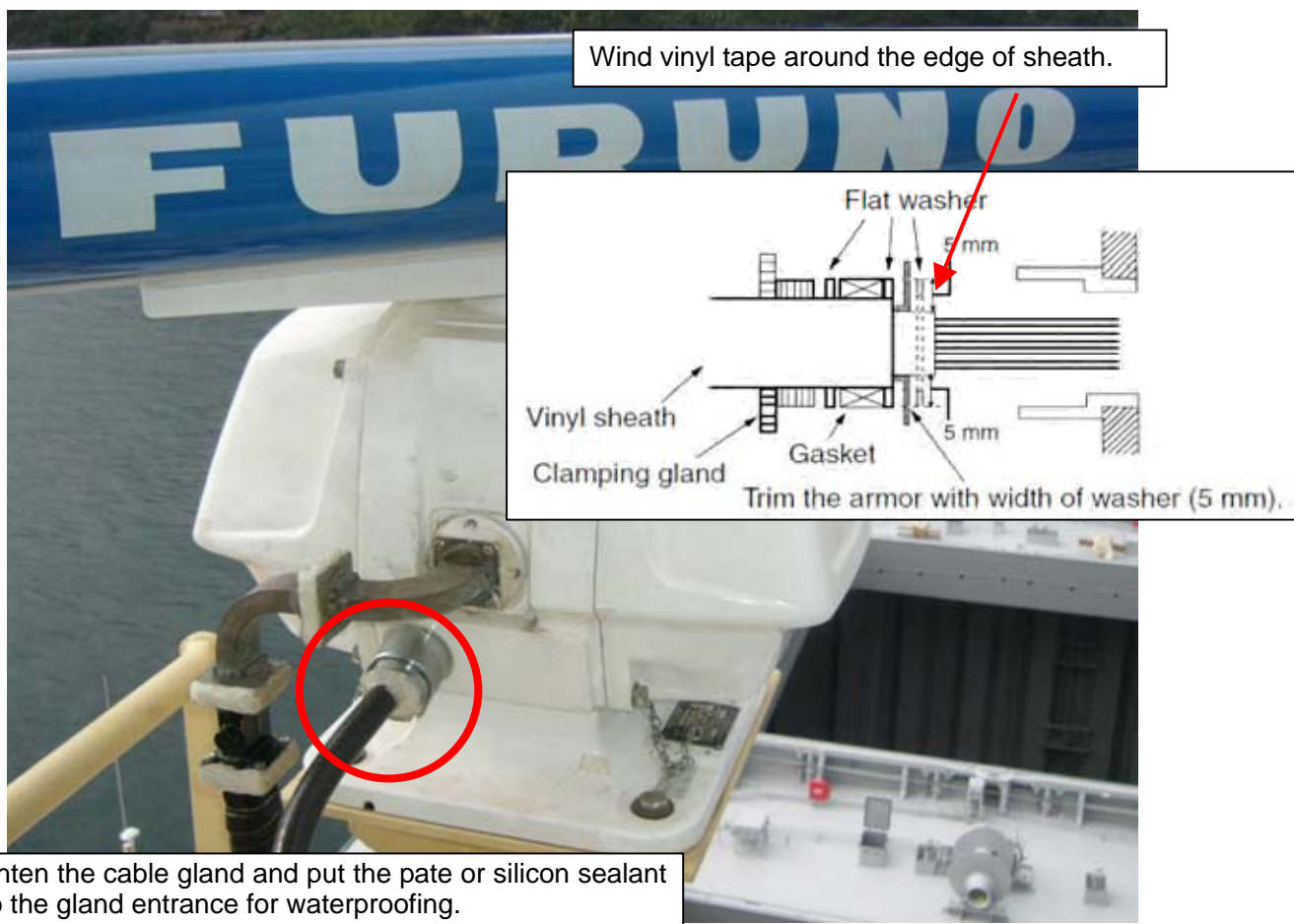

Fig. 1.2.11 Fabricating cable gland

Connect wire without fault, and bind the wires with cable tie properly.

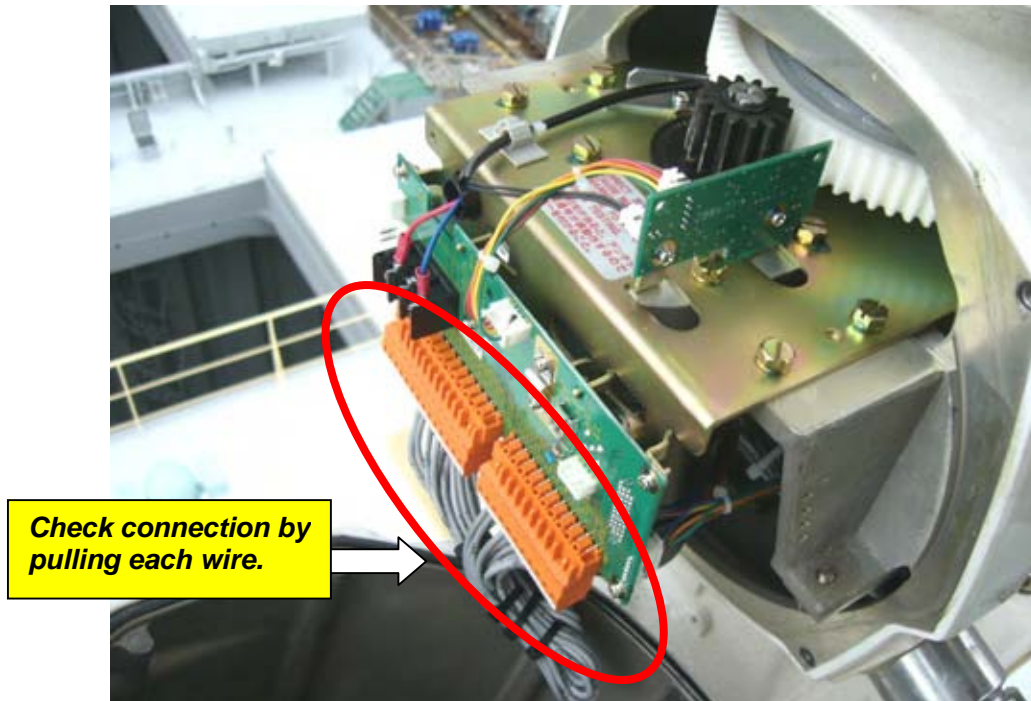

Fig. 1.2.12 Wiring in the radar antenna unit-1

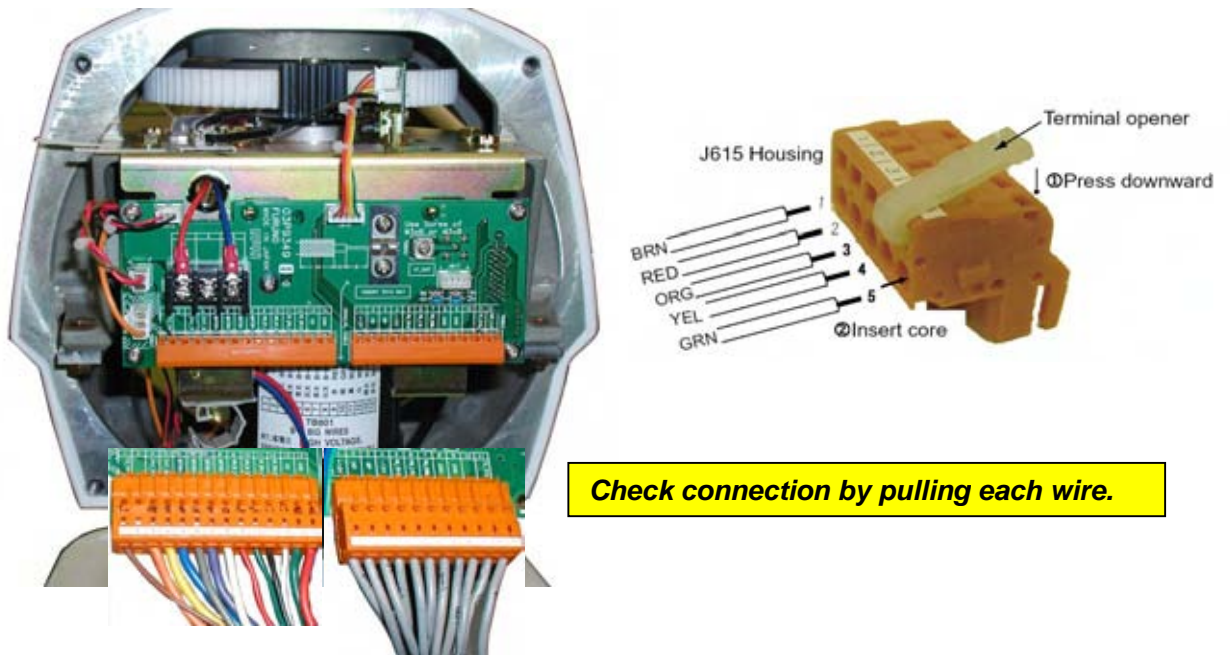

Fig. 1.2.13 Wiring in the radar antenna unit-2

1.2.5 Installation of Flexible Wave-Guide: TR-DOWN type

Following the bending radius must be taken into account to prevent the wave-guide from being damaged.

Minimum bending radius of X-band wave-guide;

E-bend: 200 mm H-bend: 400 mm.

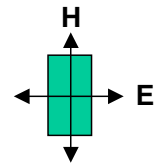

Antenna unit side

The connector of the antenna unit side has been factory-fitted. Do not remove the protection cover while laying the wave-guide.

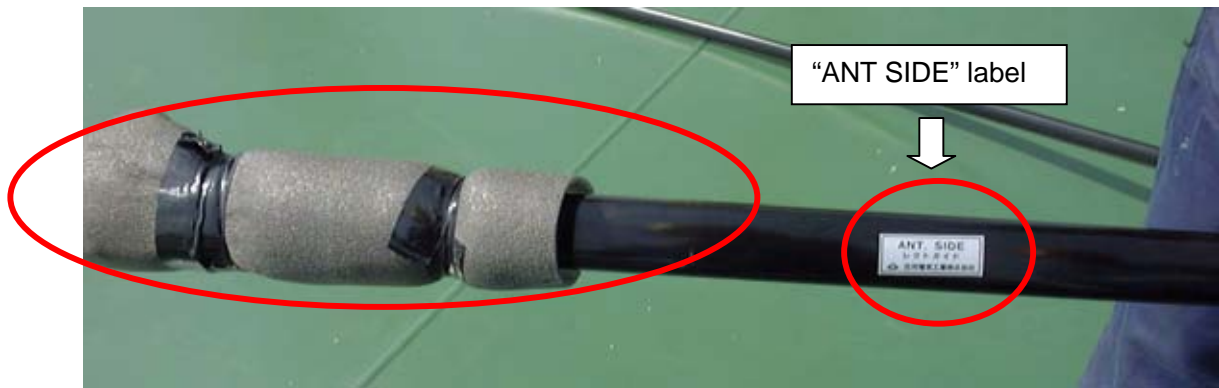

Fig. 1.2.14 Flexible wave-guide

Transceiver unit side

The Connector of the transceiver unit side has been fitted for air-tightness test. Cut the wave-guide to length at this end.

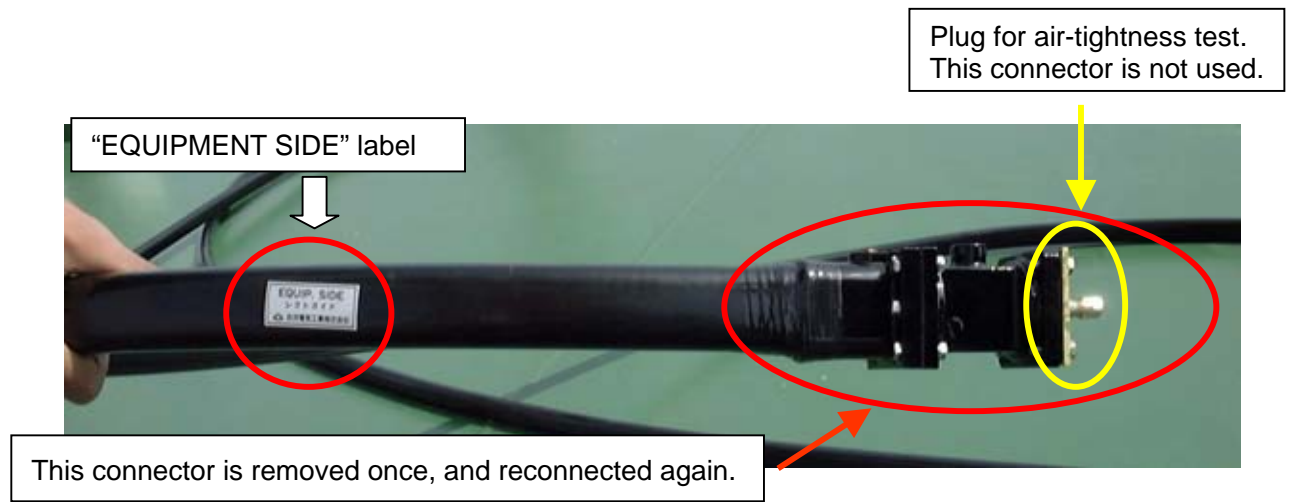
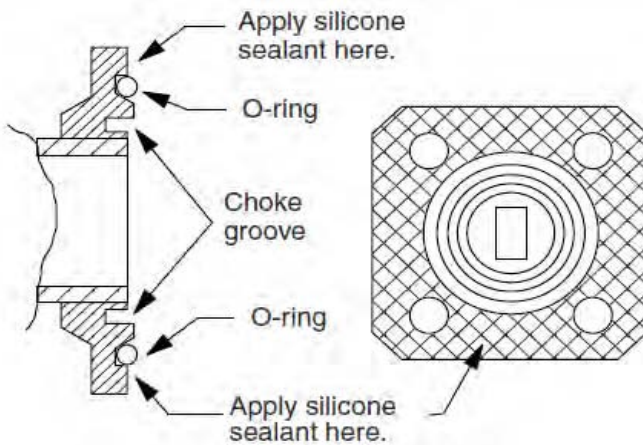

Fig. 1.2.15 Flexible wave-guide

How to put the silicon sealant on the Wave-guide connector

- Apply grease to the O-ring located in the flange.
- Coat between the coupler surfaces at the end of the coaxial cable and wave-guide flange as below with waterproofing compound (supplied with installation materials). Do not coat the O-ring.



Coat the wave-guide flange with silicone sealant evenly. Apply silicon sealant sparingly; it leaks outs lightly when the fixing bolts are tightened. Be sure no silicon sealant contacts the choke groove and wave-guide.



E-bend, H-bend or twist bend is used to joint between wave-guide and radar antenna unit, if necessary.

Fig. 1.2.16 Installation of wave-guide

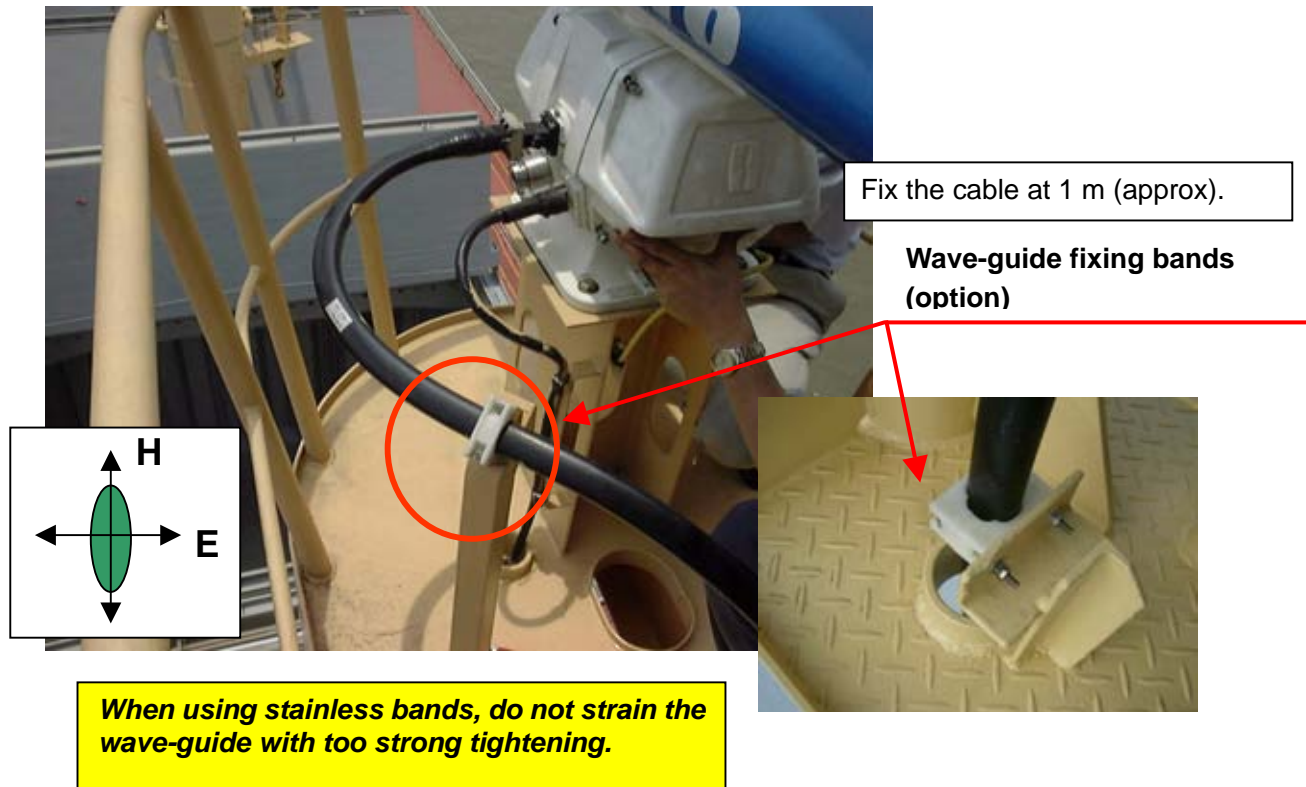

Fig. 1.2.17 Flexible wave-guide

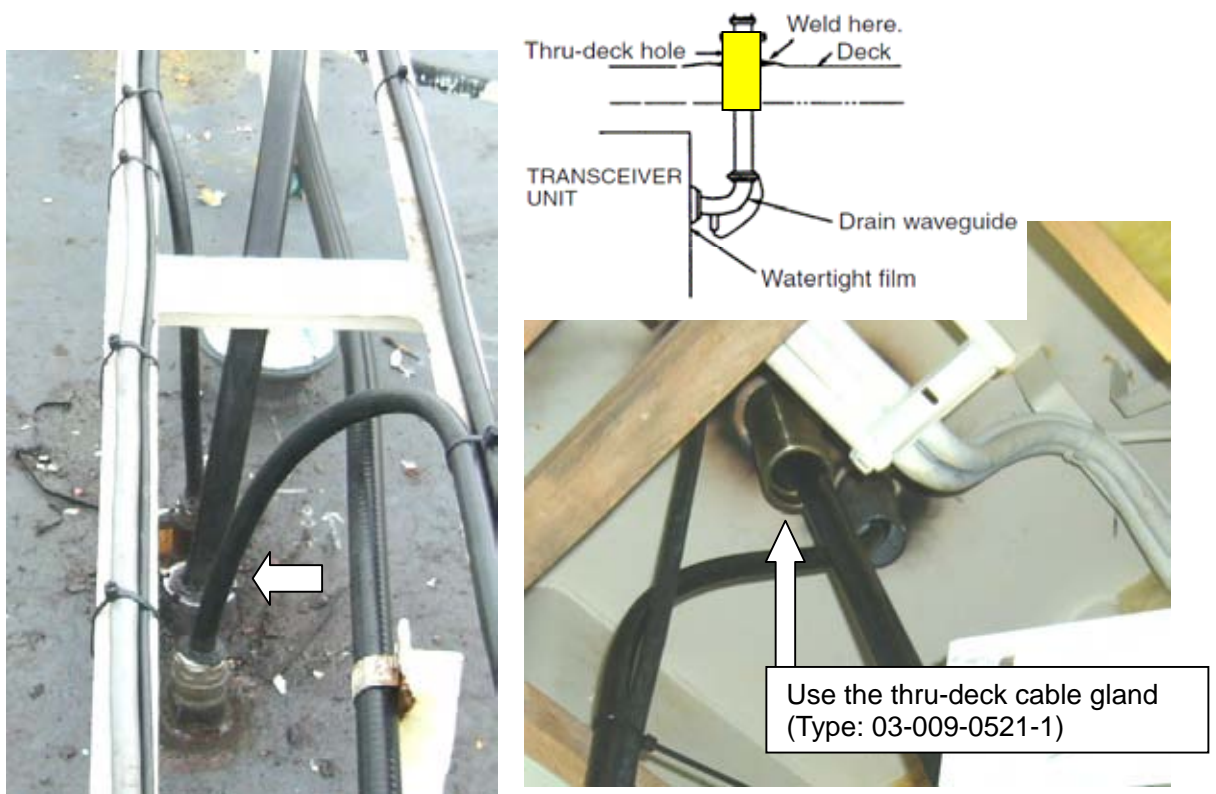
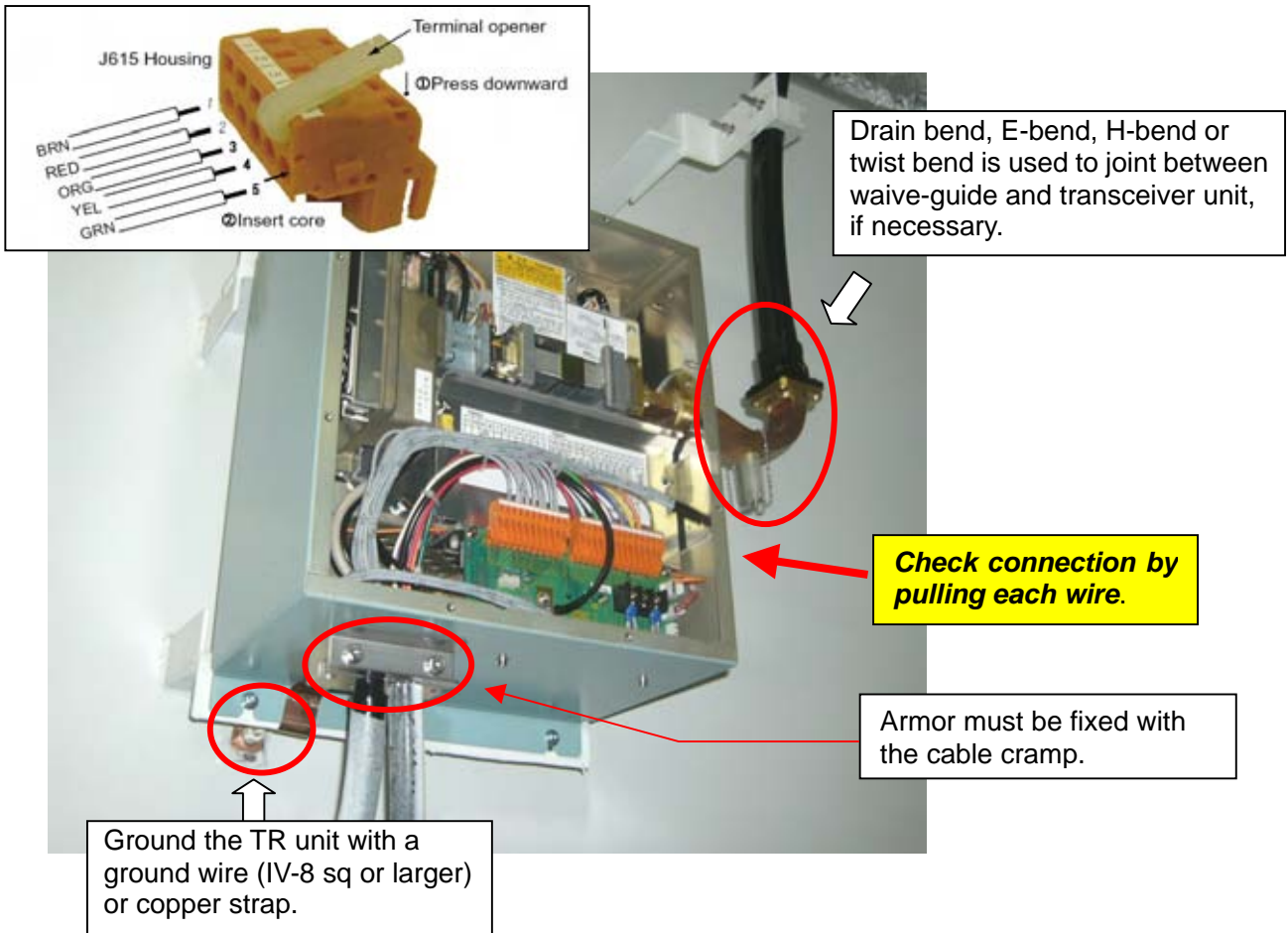

Fig. 1.2.18 Installing thru-deck cable gland

1.2.6 Mounting of X-Band Radar TR unit: TR-DOWN type



E-bend (option)

H-bend (option)

Fig. 1.2.19 Installation of TR unit

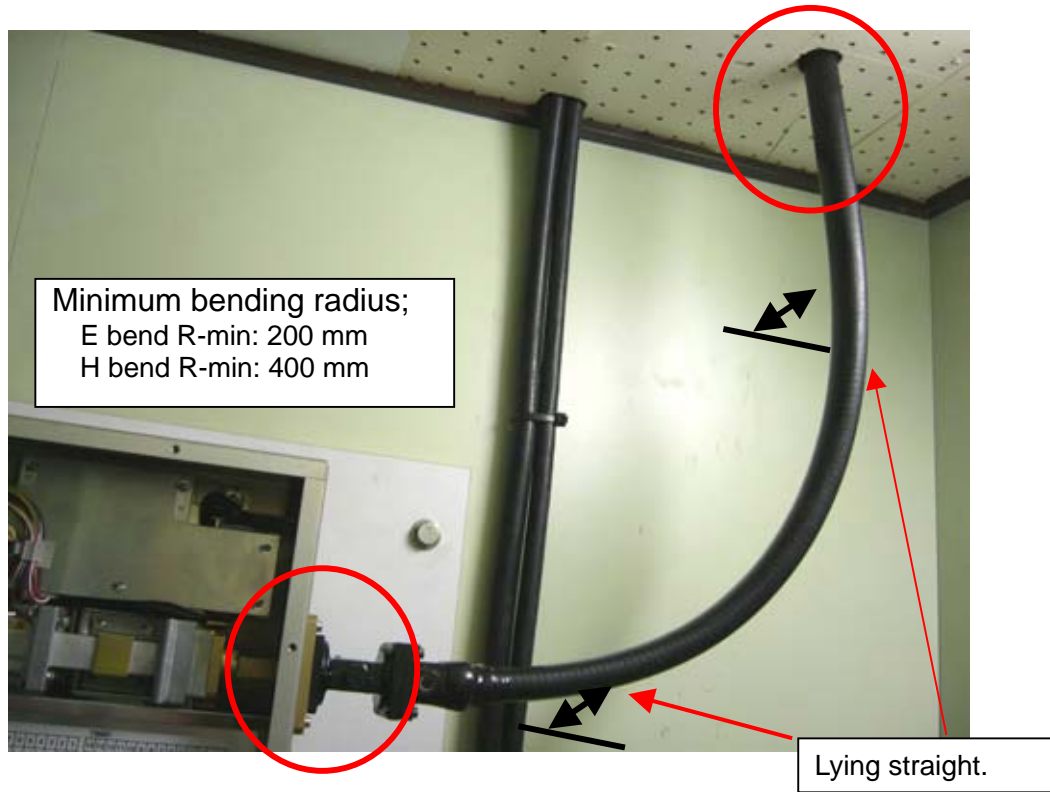

When pulling down the wave-guide from the ceiling, select the position so as to keep the minimum bend of wave guide.

When connecting the waveguide, take care not to apply force on the "Converter WG." It may increase the gap shown in the figure below. It may allow microwaves to leak through the gap, and it causes troubles.

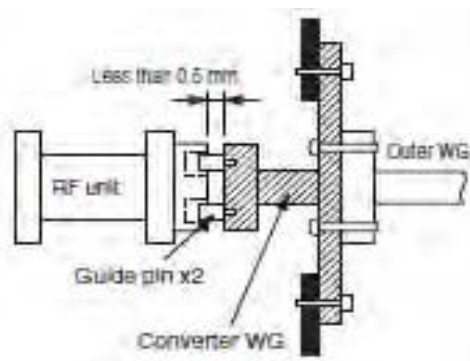

Fig. 1.2.20 Installation of TR unit

1.2.7 Fabricating Wave-guide

1. Cutting wave-guide

Cut the wave-guide at the height of wave-guide outlet of the TR unit.



Fig. 1.2.21 Cutting wave-guide

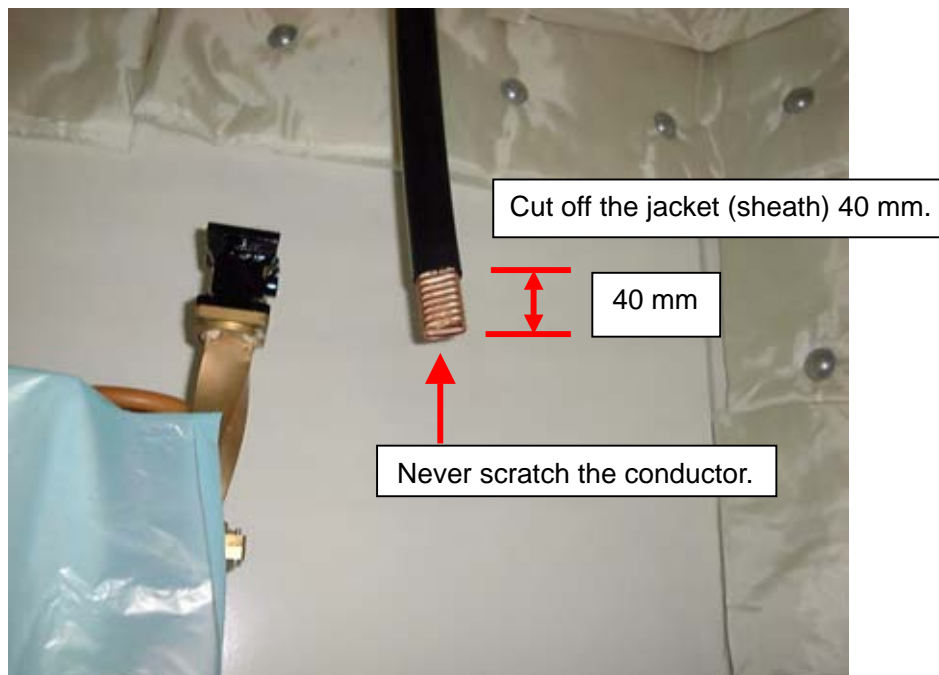

Fig. 1.2.22 Wave-guide termination

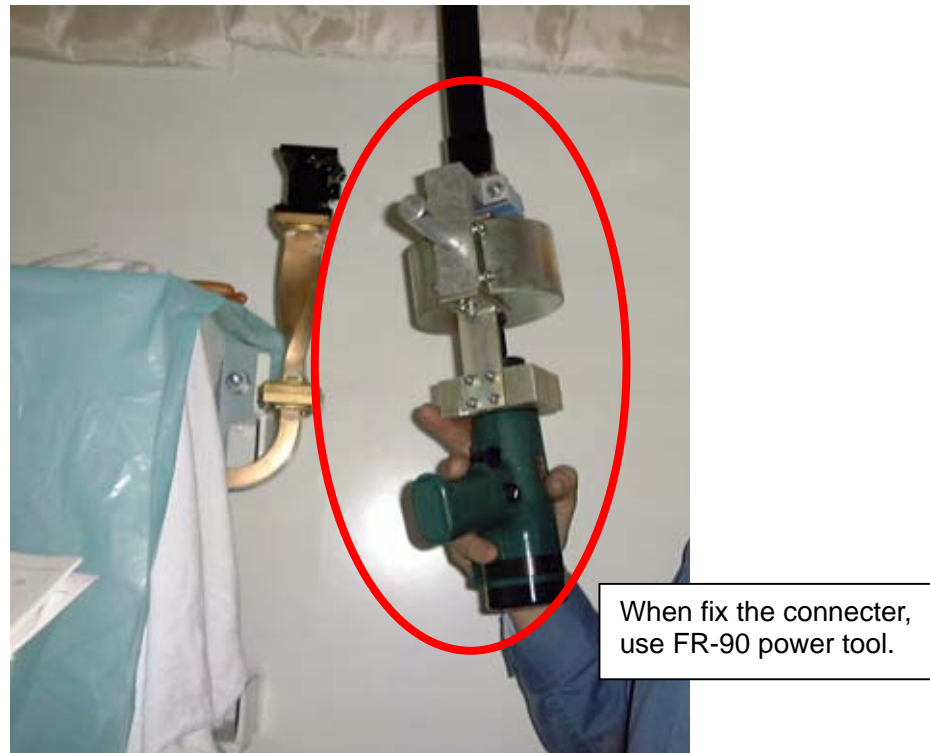

Fig. 1.2.23 Widening wave-guide opening

The Wave-guide end must be smooth and no crack.
Radar performance degrades if the flange inadequately is fitted.

Good

Appropriate tool is used



No crack on the wave-guide and smooth surface

No Good

Appropriate tool is not used

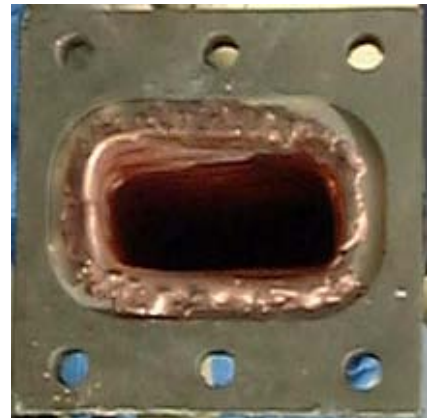

Crack and rough surface

Fig. 1.2.24 Fabrication of wave-guide connector

2. Fabricating wave-guide connector

After assembling the connector, pouring of silicone sealant to filling opening, then wind the self-bounding tape between the end of connector and wave guide, half-lapped in two layers. Further, wind vinyl tape in two layers.

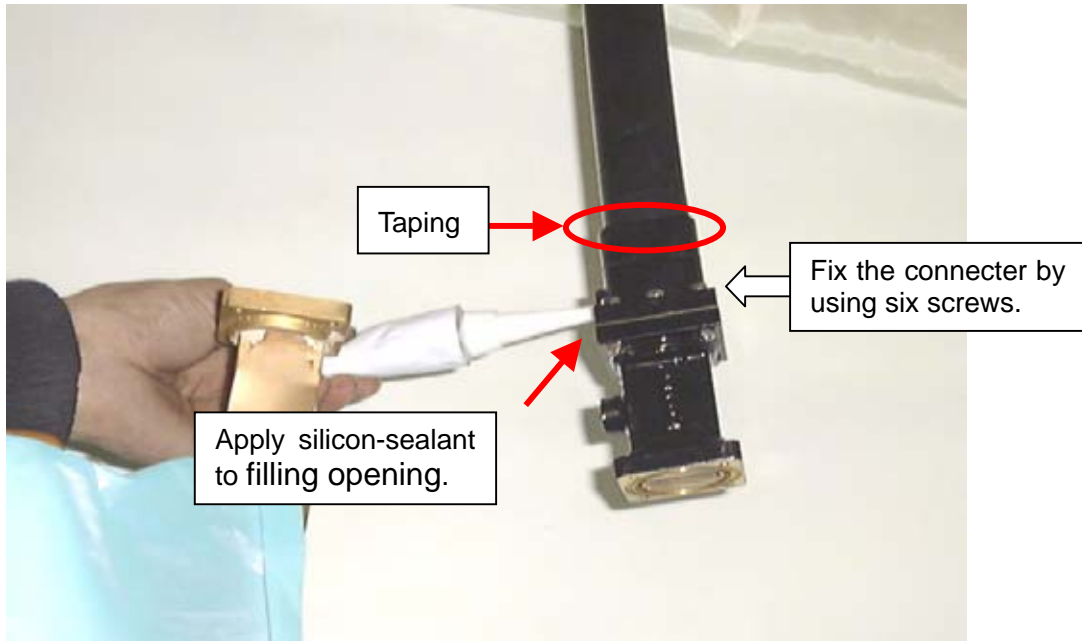

Fig. 1.2.25 Fitting wave-guide connector

3. Connect the wave-guide to the TR unit.**Direct connection**

Fig. 1.2.26 Direct connection

Connection using drain wave-guide

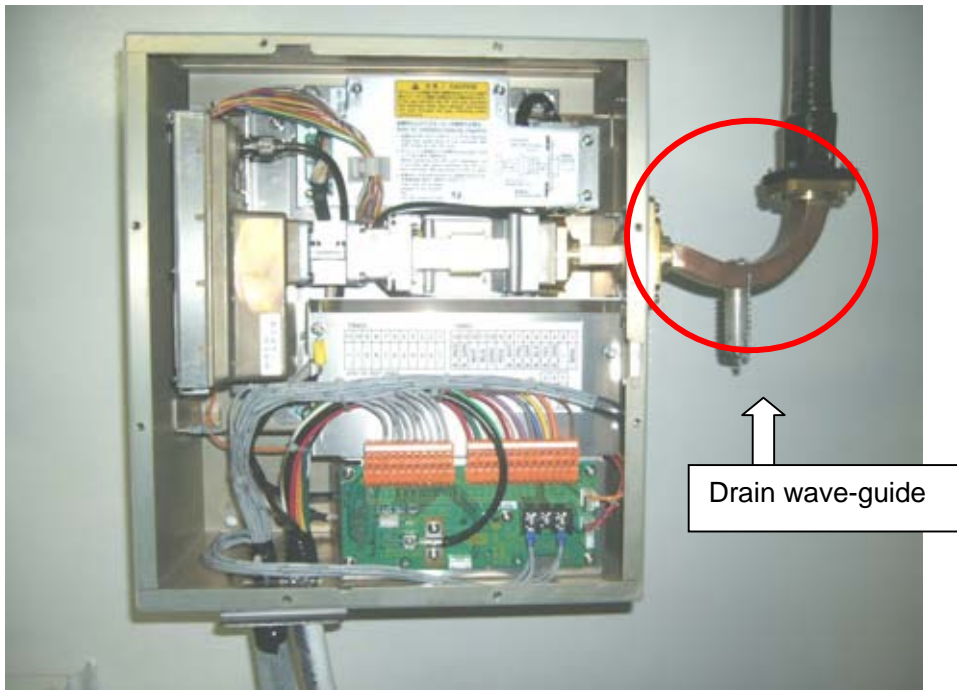
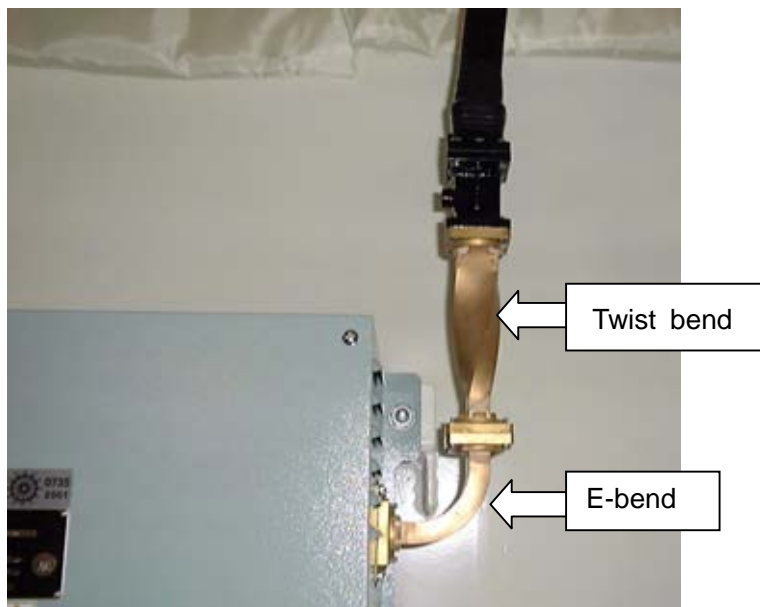

Fig. 1.2.27 Drain wave-guide

Connection using E-bend, H-bend or Twist-bend



Radar performance may degraded by using joint bends.

Fig. 1.2.28 Fixing with joint bends

Tools for fabricating X-Band Radar Wave-Guide

If necessary, order these tools to FURUNO.

Type: OP03-123, Code No. 0084488800



Code No.	Item	Type	Qty
00015179800	FR-90 power tool	R4KG5549 03S9791-0	1set
10020750000	Edge gauge	03-009-0530-0	1
10020754000	Gauge (Square)	03-009-0534-0	1
00080584700	Tool box	#2207	1
00080584800	Brush	8 inch	1
00080584900	Wrench	For M4	2
00080585000	Hack saw	HFJ-12	1
00080585100	Saw	250 m x 24 mm	6
00080585200	File	L150	1
00080585300	File	L150	1
00080585400	Knife	DK-N	1
00080585500	Heavy duty snips	K30, 190	1 set

Fig. 1.2.29 Tools

1.3 Installation of S-Band Radar

1.3.1 Mounting of Radar antenna

Locating of Performance monitor should be mounted to the stern side.

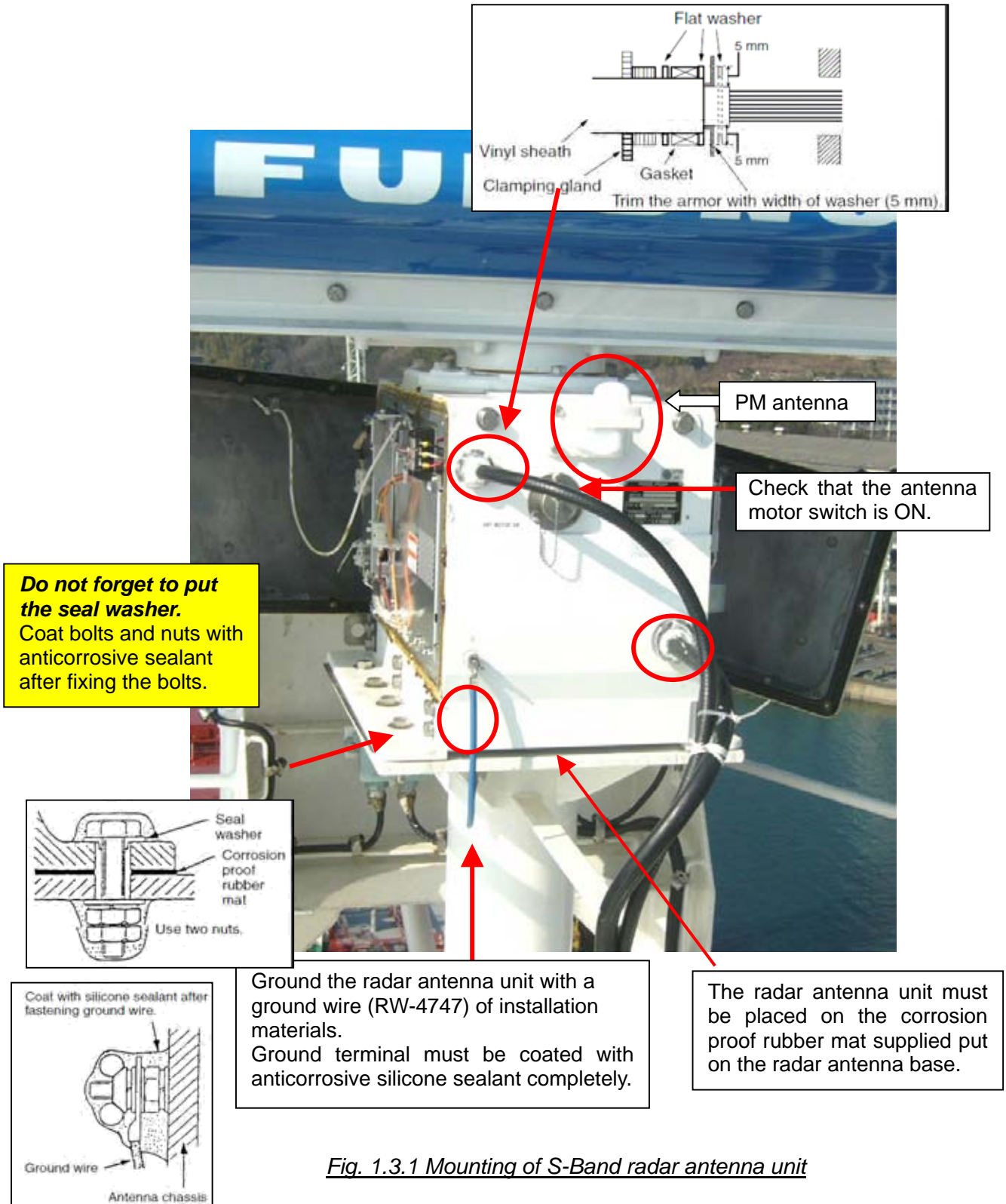

Fig. 1.3.1 Mounting of S-Band radar antenna unit

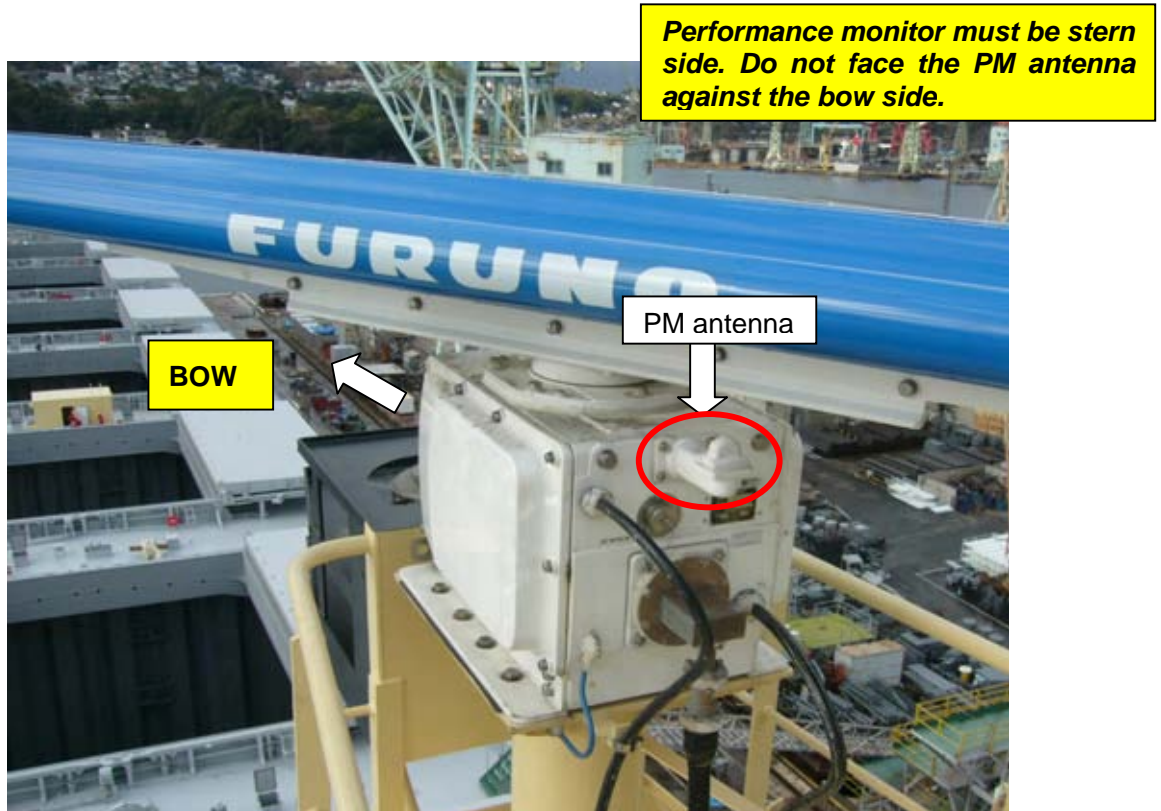

Fig. 1.3.2 PM antenna

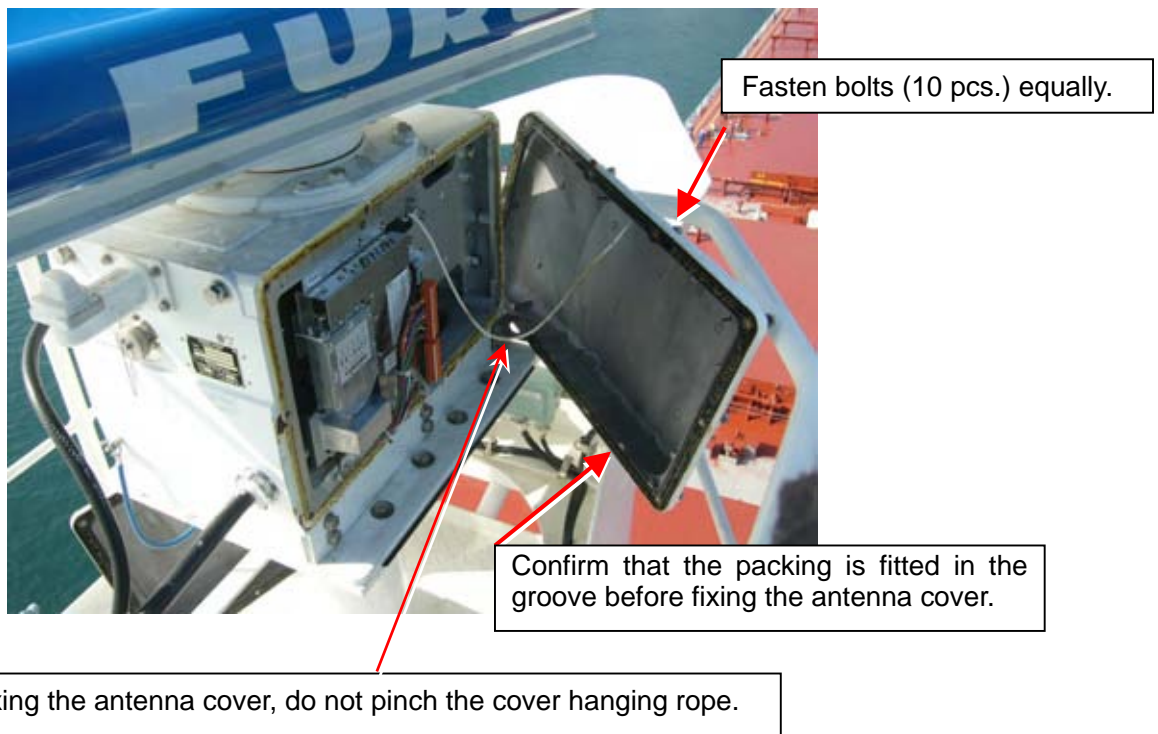
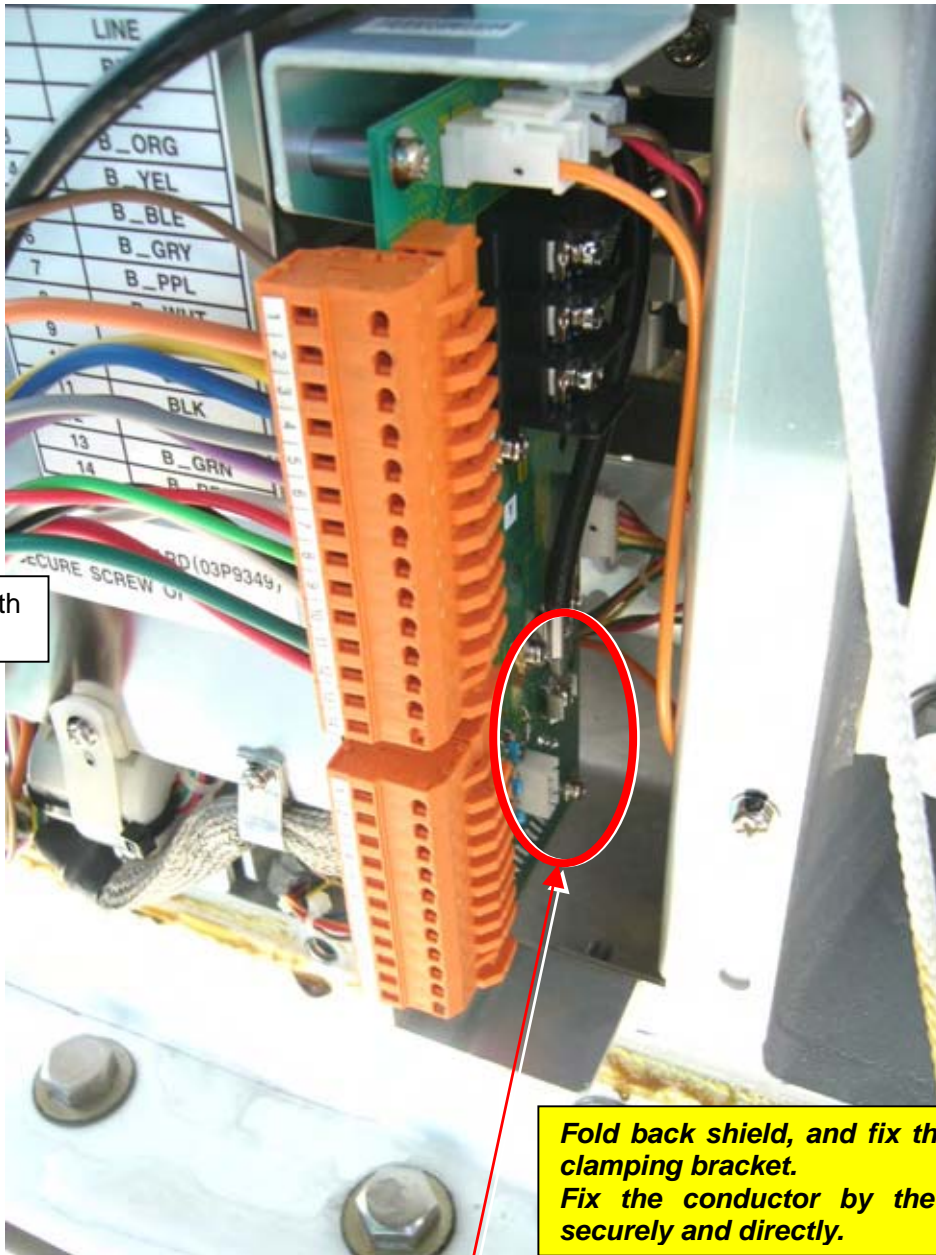

Fig. 1.3.3 Fixing antenna cover

1.3.2 Mounting of S-Band Radar: TR-UP type antenna



Bind cables with cable ties.

Fold back shield, and fix the shield with clamping bracket. Fix the conductor by the metal plate securely and directly.

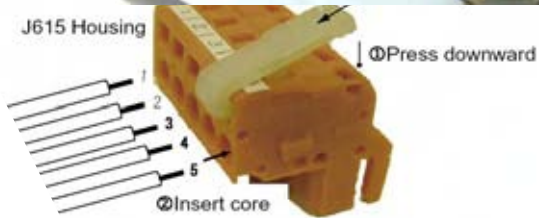

1. Insert opener
2. Push opener
3. Insert a core
4. Release opener

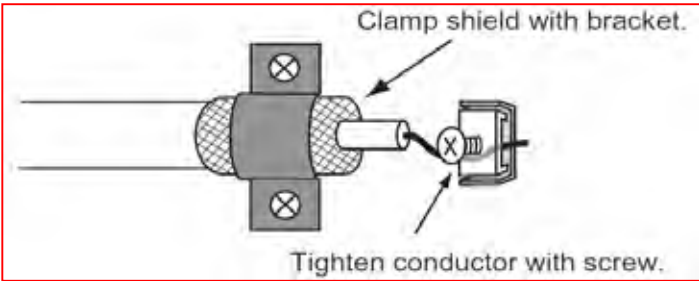

Fig. 1.3.4 Wiring of cables

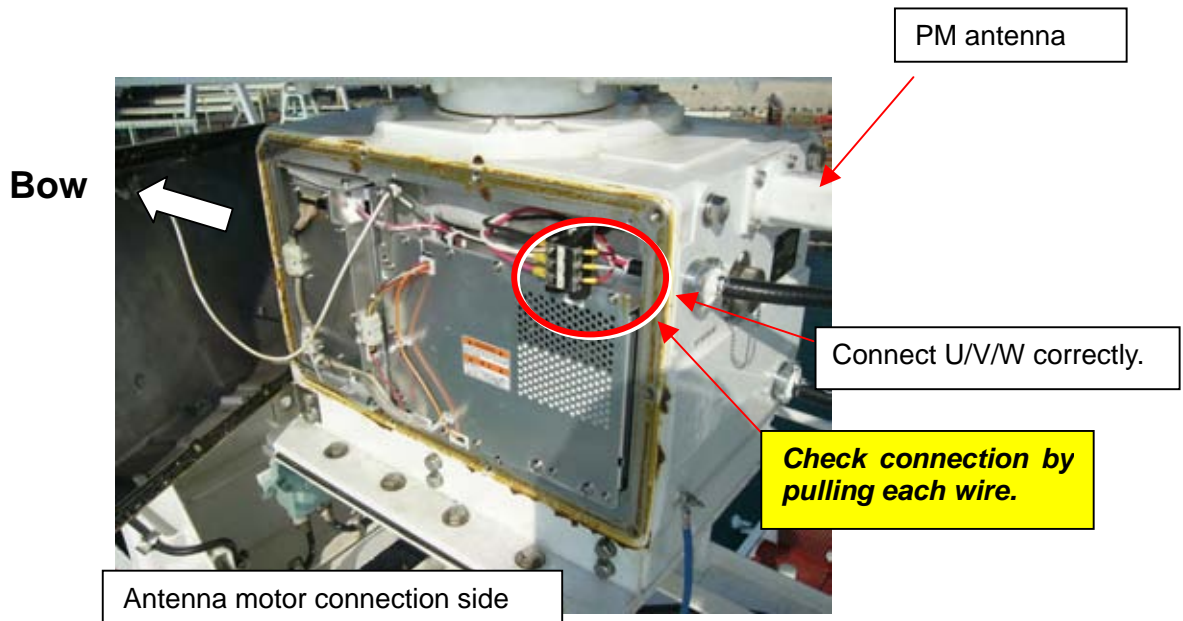

Fig. 1.3.5 Mounting of S-Band Radar; TR-UP type antenna unit-1



Fig. 1.3.6 Mounting of S-Band Radar; TR-UP type antenna unit-2

1.3.3 Mounting of S-Band Radar: TR-DOWN type antenna

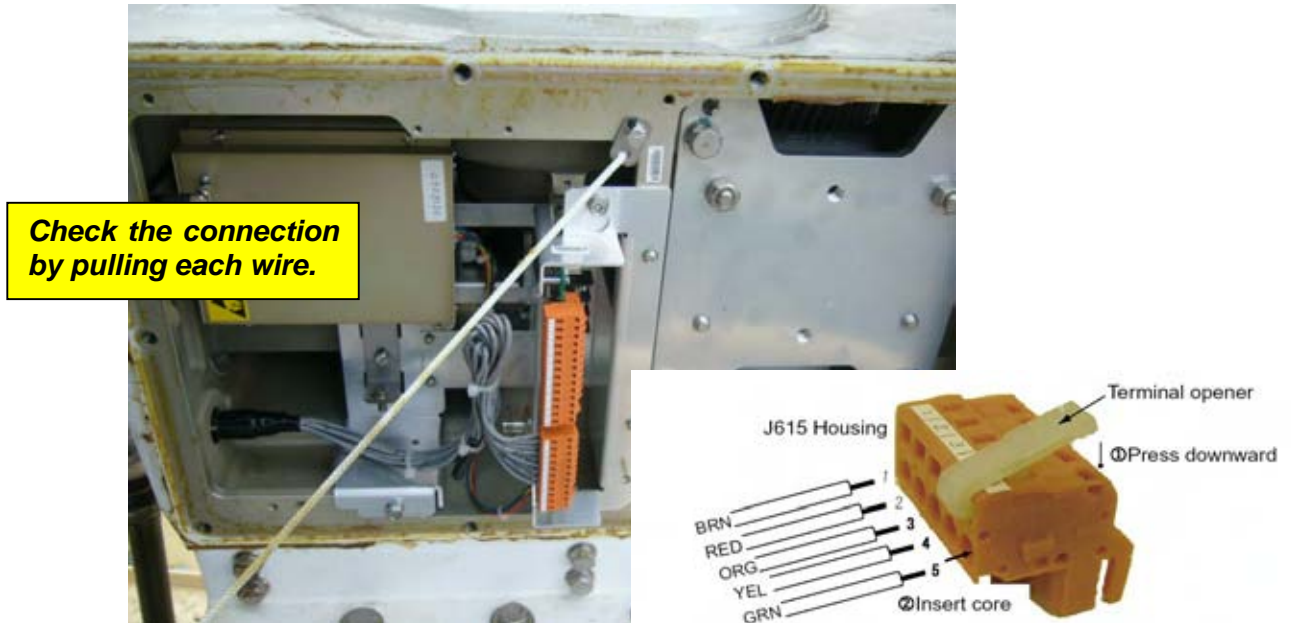

Fig. 1.3.7 Connection cables to the WAGO connector

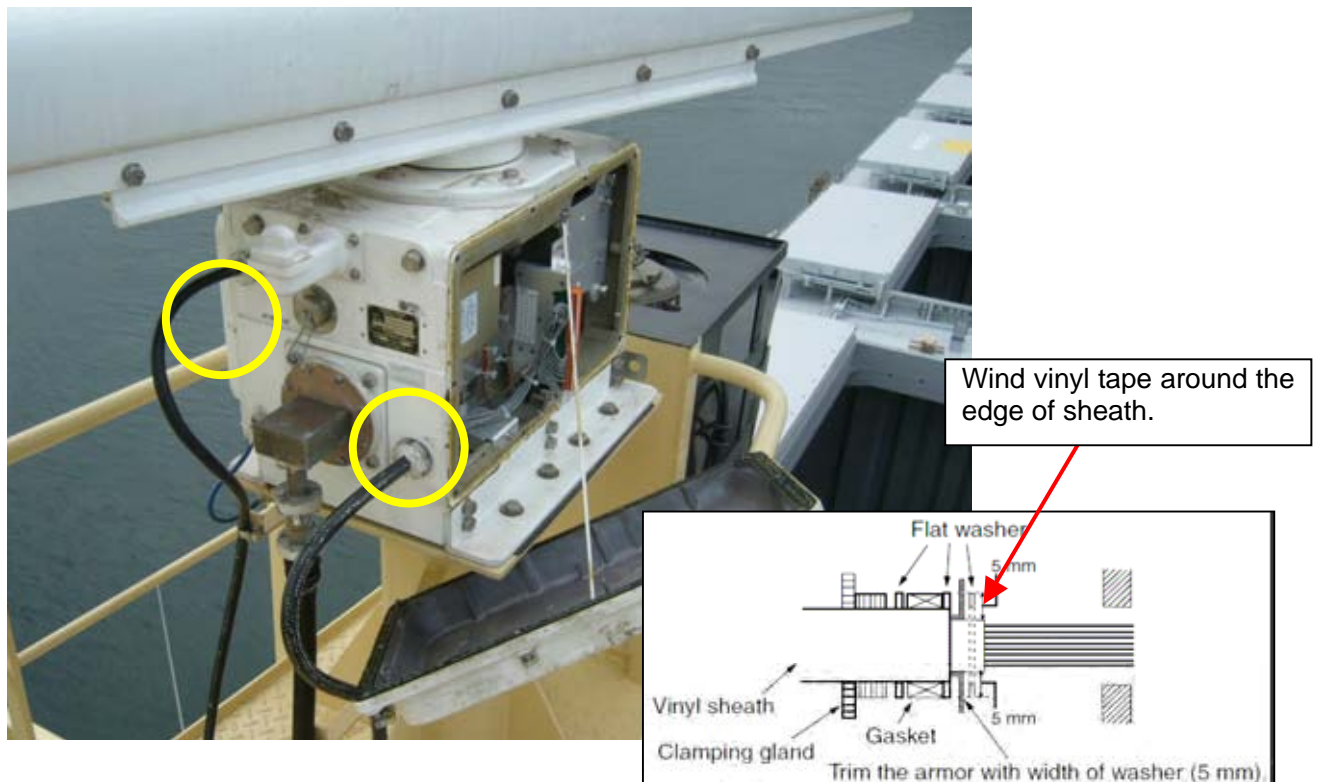
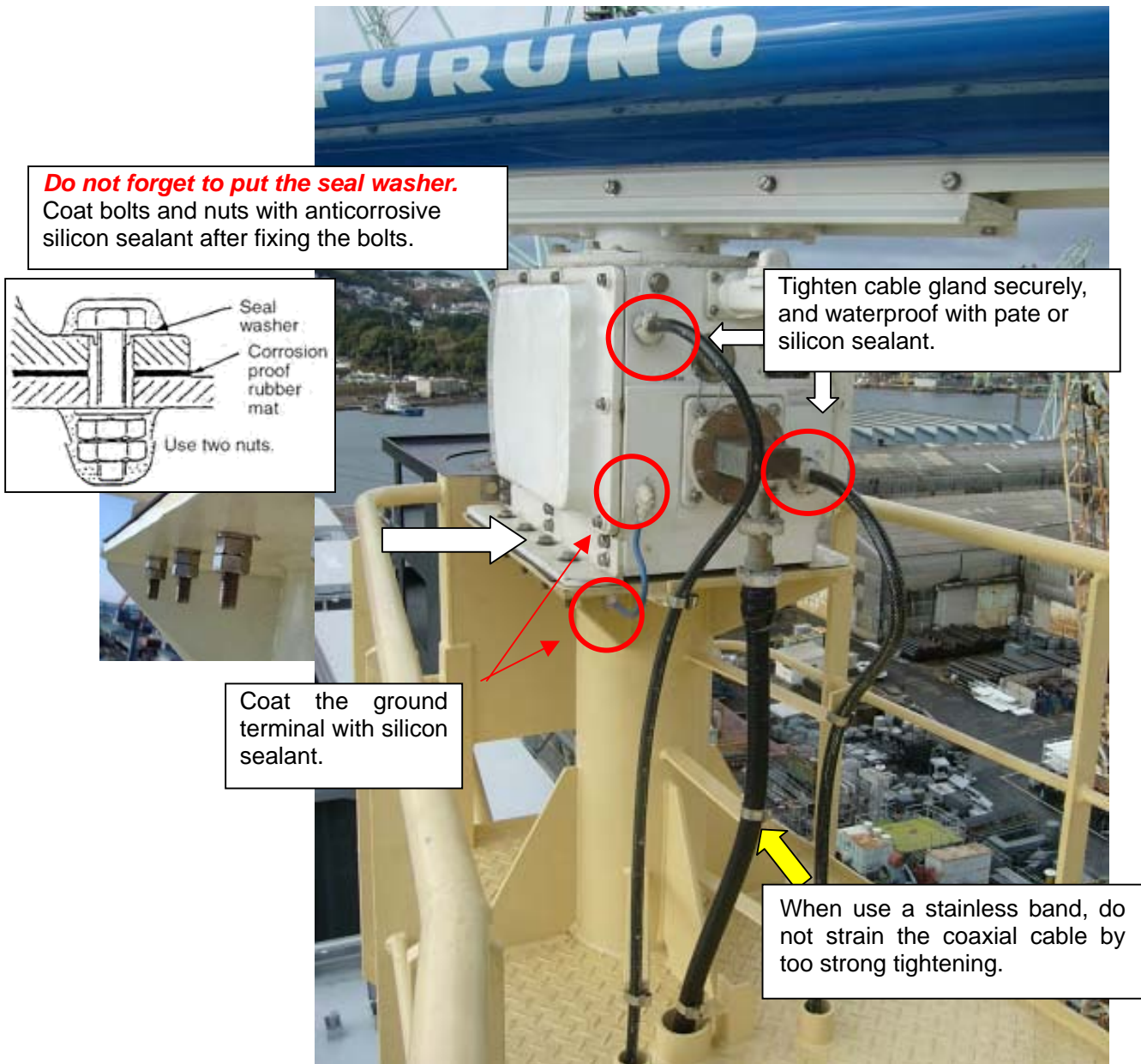

Fig. 1.3.8 Fixing cable gland



Use optional fixture clamping metal for fixing coaxial cable.

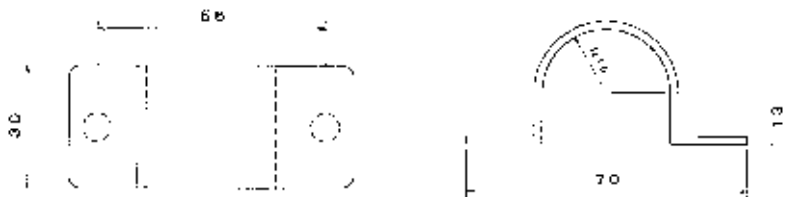

Fig. 1.3.9 Mounting of S-Band Radar: TR Down type antenna unit

1.3.4 Laying coaxial cable of S-Band Radar

When bending the coaxial cable, keep enough radiuses to prevent transformation of the coaxial cable. Generally, keep radius of 150 mm or more.

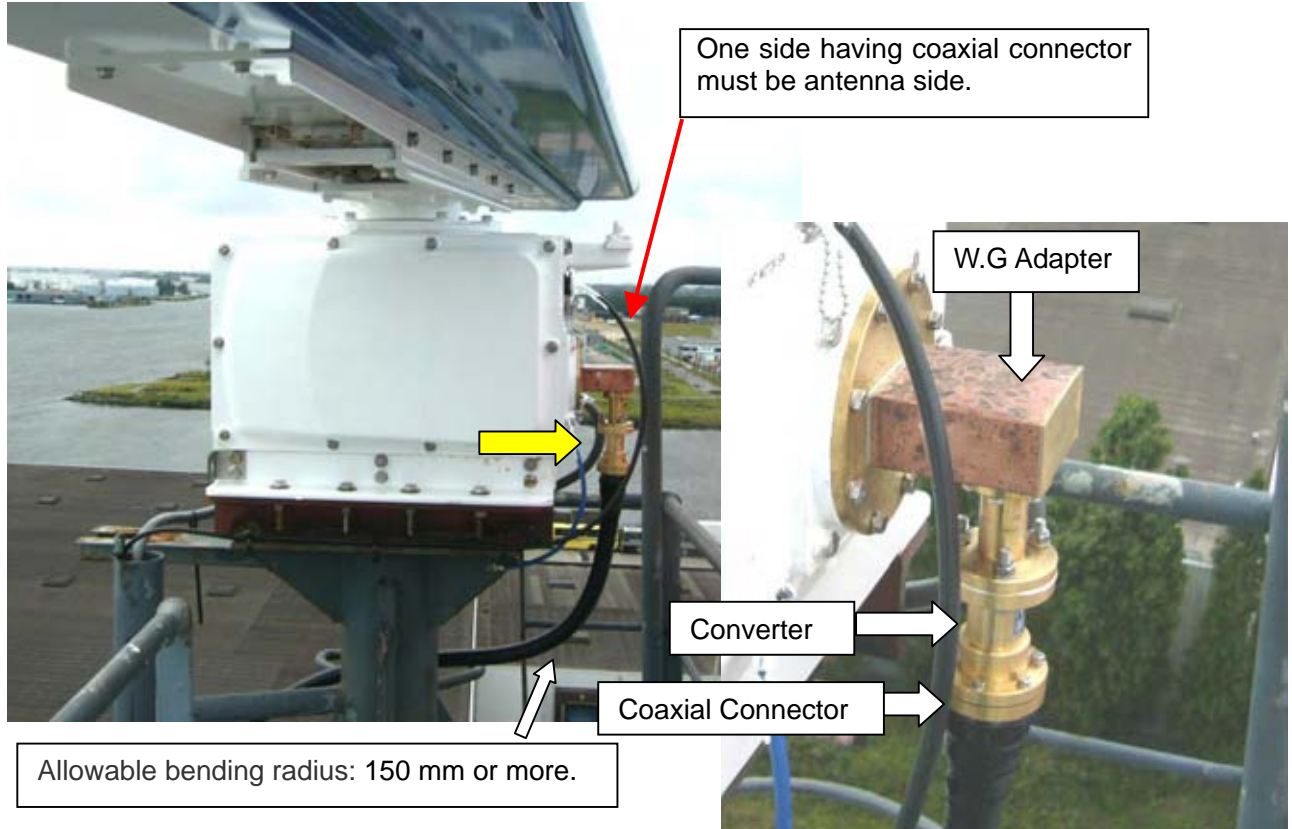
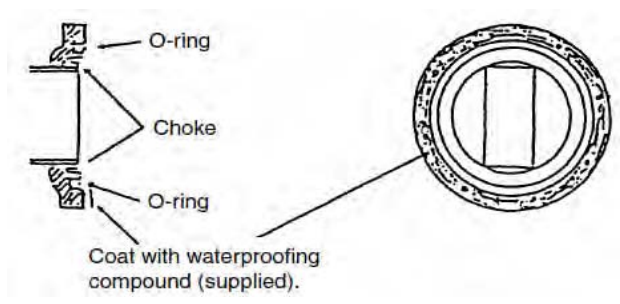

Fig. 1.3.10 Fixing coaxial cable

Connecting the coaxial connector

1. Unfasten eight bolts (M6x20) to remove the flange cover from the radar antenna unit.
2. Apply silicon grease on the O-ring of the wave guide flange of the radar antenna unit.
3. Coat between the coupler surfaces at the end of the coaxial cable and wave-guide flange as below with waterproofing compound (supplied with installation materials). Do not coat the O-ring.
4. Screw 8 bolts unfastened at the step 1 to fix the coupler to the flange. Tighten screws securely.





Allowable bending radius: 150 mm or more



Fix the thru-deck cable gland (Option: type. 03-009-0521-1) to a deck by welding.



Fig. 1.3.11 Thru-deck cable gland

1.3.5 Mounting of S-Band Radar: TR-UP type Transceiver unit

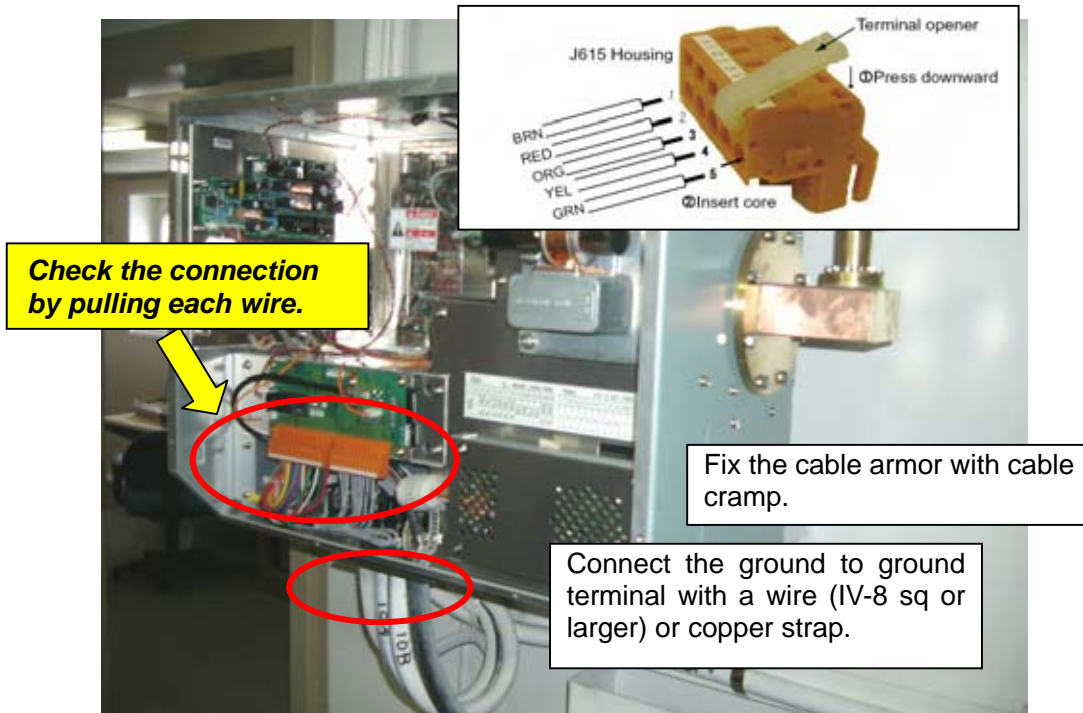

Fig. 1.3.12 Installation of transceiver unit

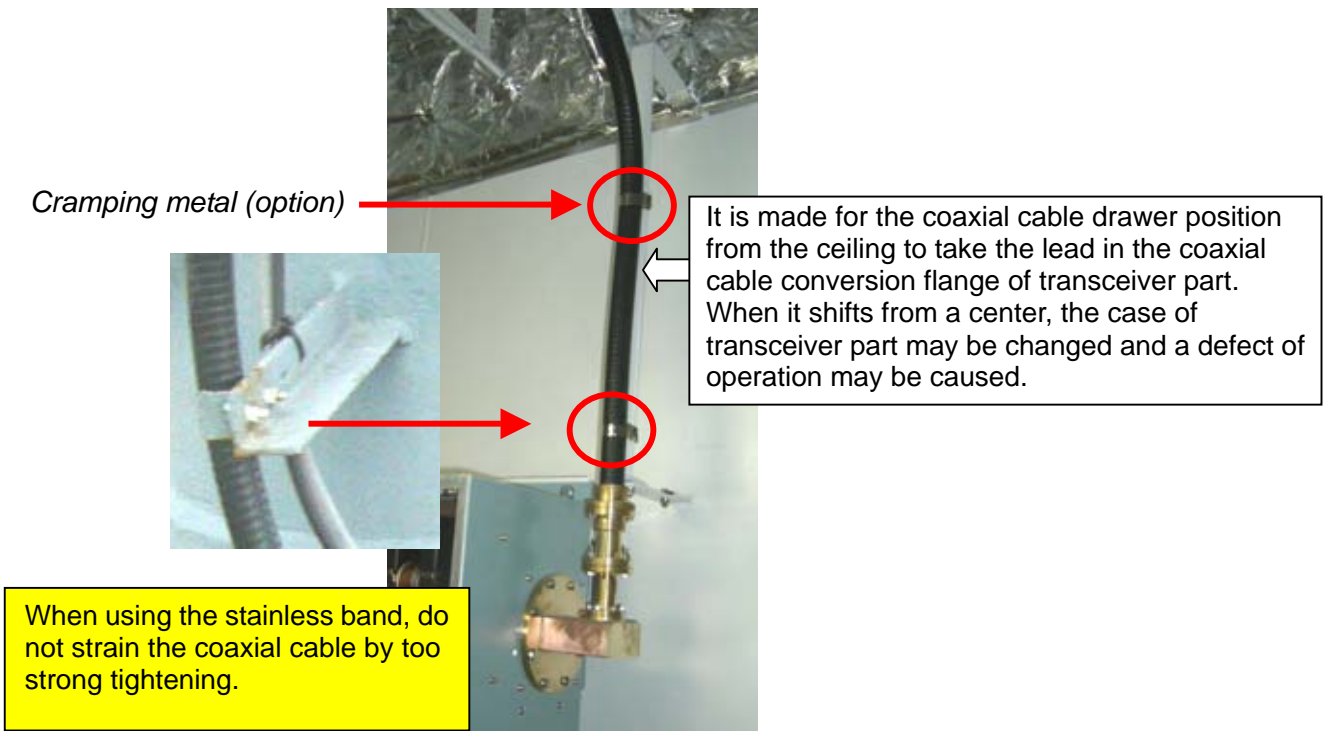

Fig. 1.3.13 Fixing coaxial cable

1.3.6 Fabrication of coaxial cable and connector

Installation Material

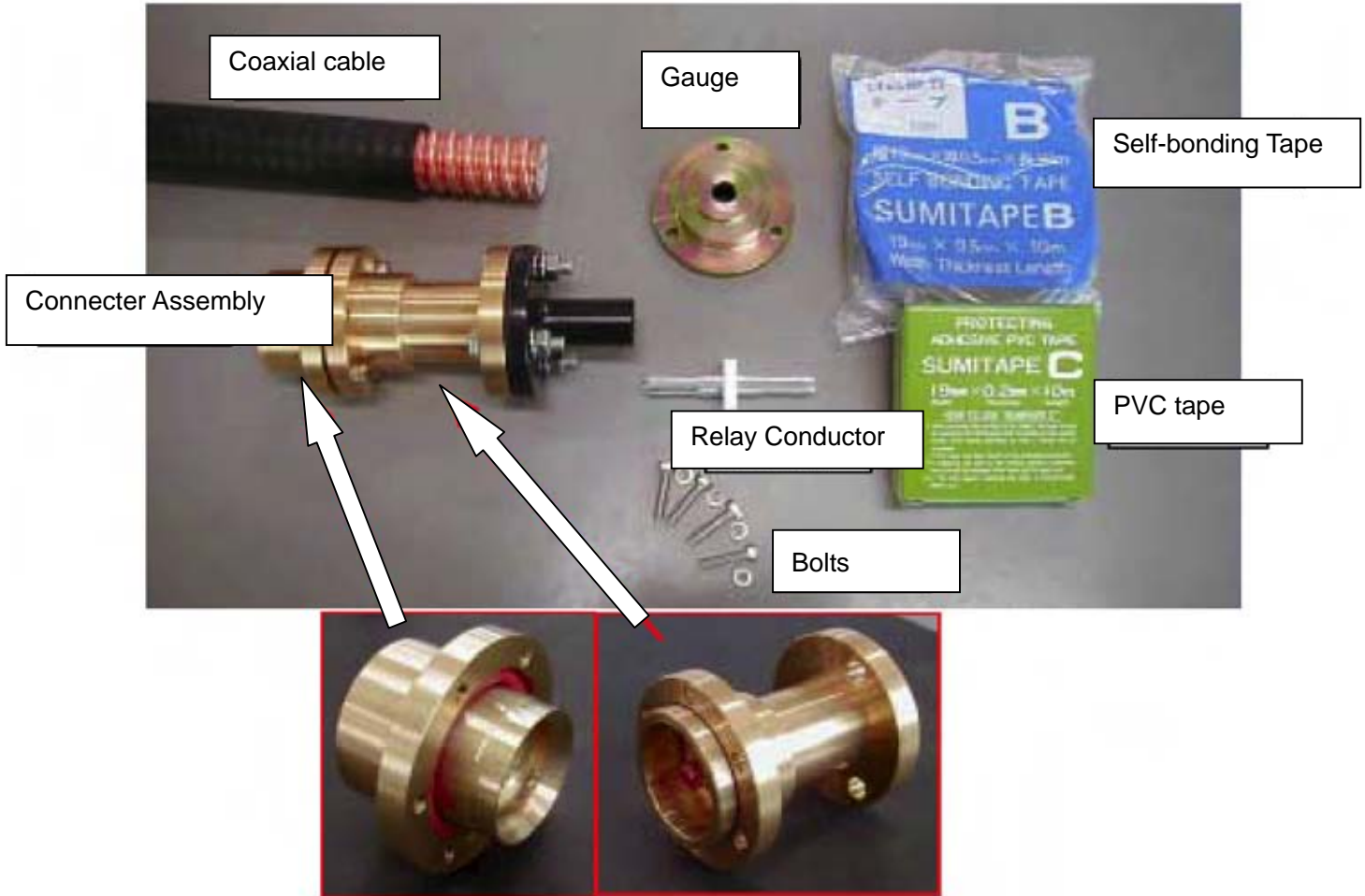

Fig. 1.3.14 Coaxial connector assembly

Note 1: Prevent dust into the cable during the work.

Note 2: A minimum cable bending radius of 150 mm must be observed at the cable run.
When bending the cable twice or more in the close points, the bending radius should be more than 250 mm.

Note 3: Do not lose the Relay Conductor.

1. Cut coaxial cable



Fig. 1.3.15 Connection of coaxial cable

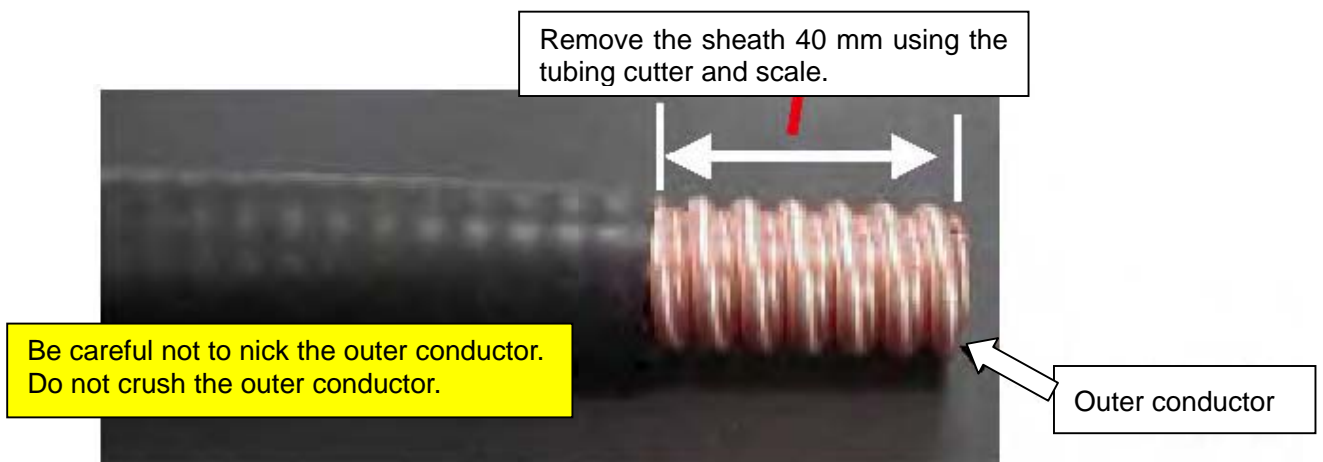
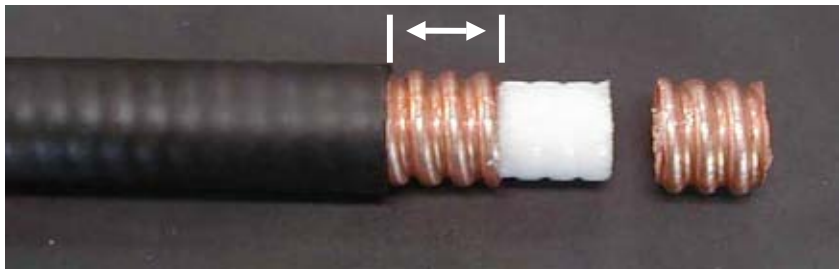

Fig. 1.3.16 Fabricating coaxial cable-1

2. Remove the outer conductor and the insulator.

24.5 to 25.0 mm



Remove the insulator in the outer conductor 6 mm.

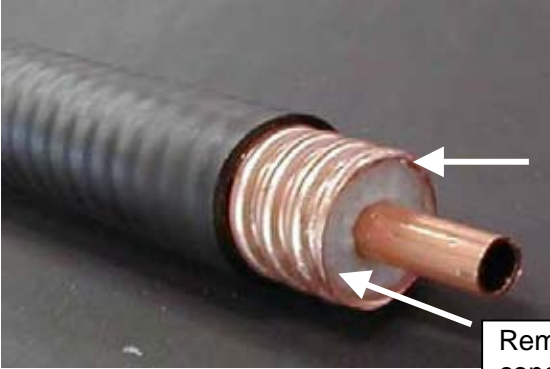

Remove burr at the edge of outer conductor with the file.

Remove the insulator in the outer conductor 6 mm.

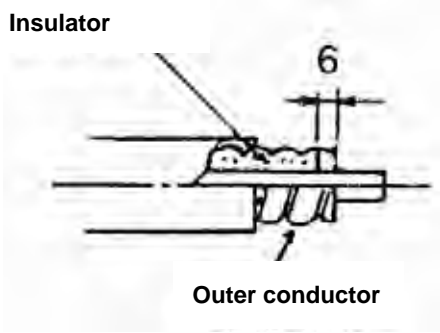
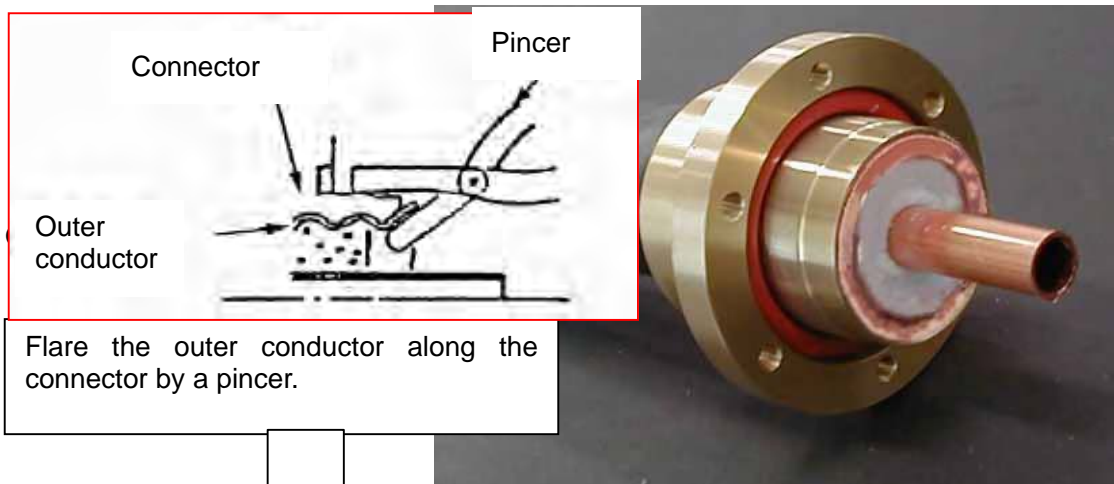
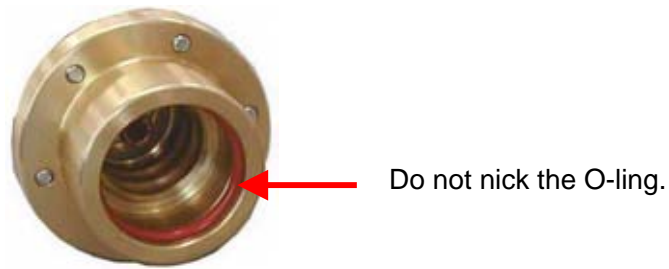
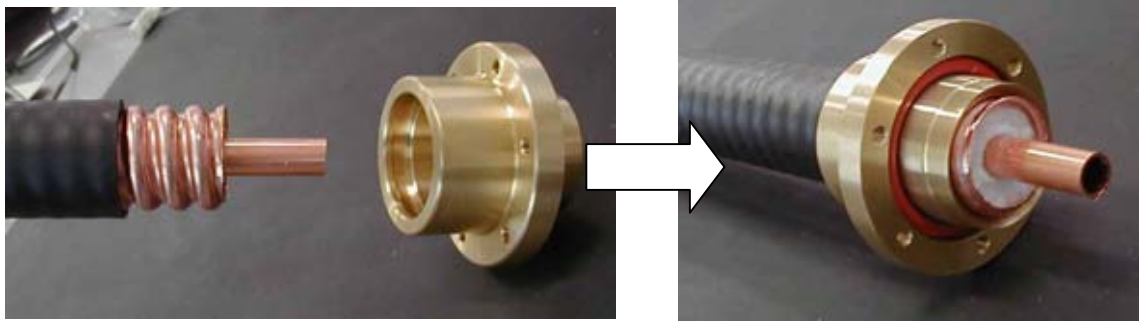

Fig. 1.3.17 Fabricating coaxial cable-2

3. Insert the connector.



Flare the outer conductor along the connector by a pincer.

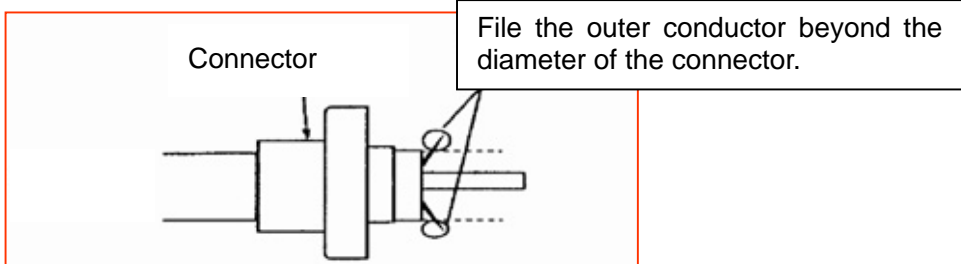

Fig. 1.3.18 Fabricating coaxial cable-3

4. Insert the gauge.

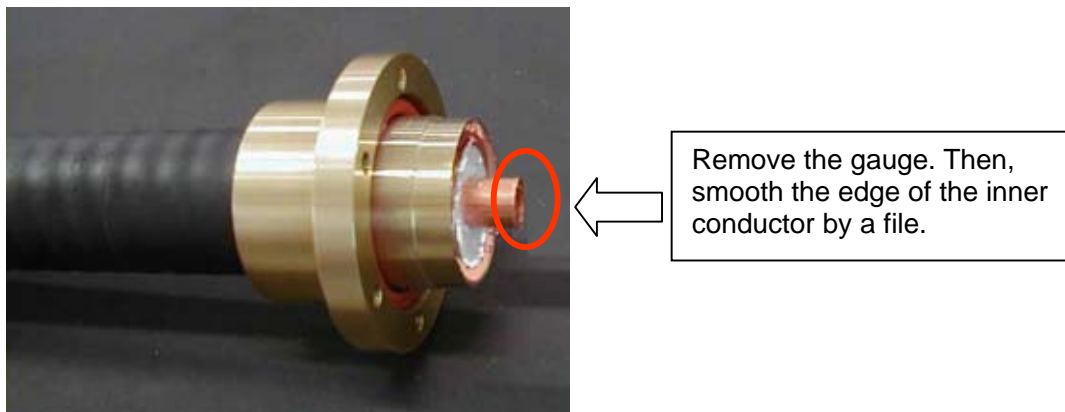
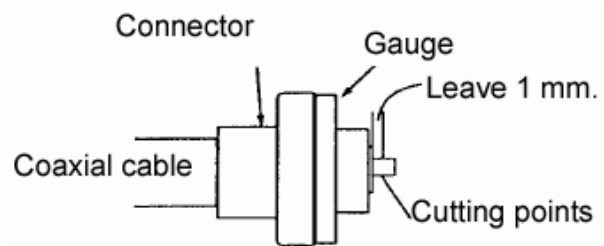
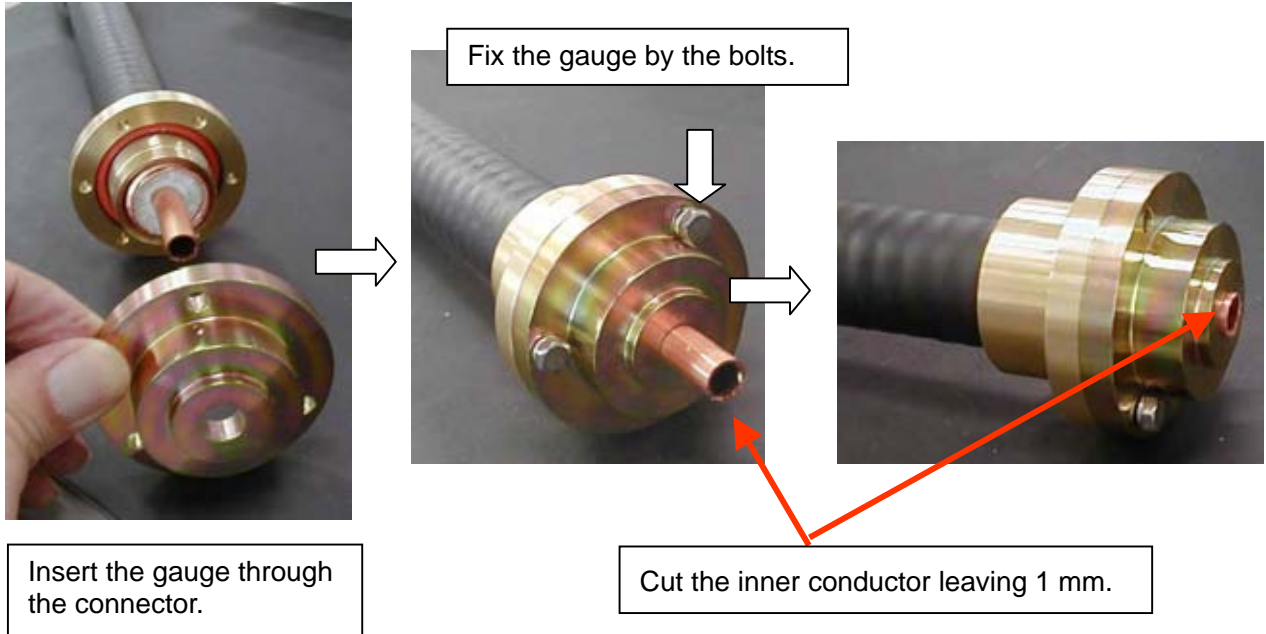

Fig. 1.3.19 Fabricating coaxial cable-4

5. Assemble other parts of the connector.

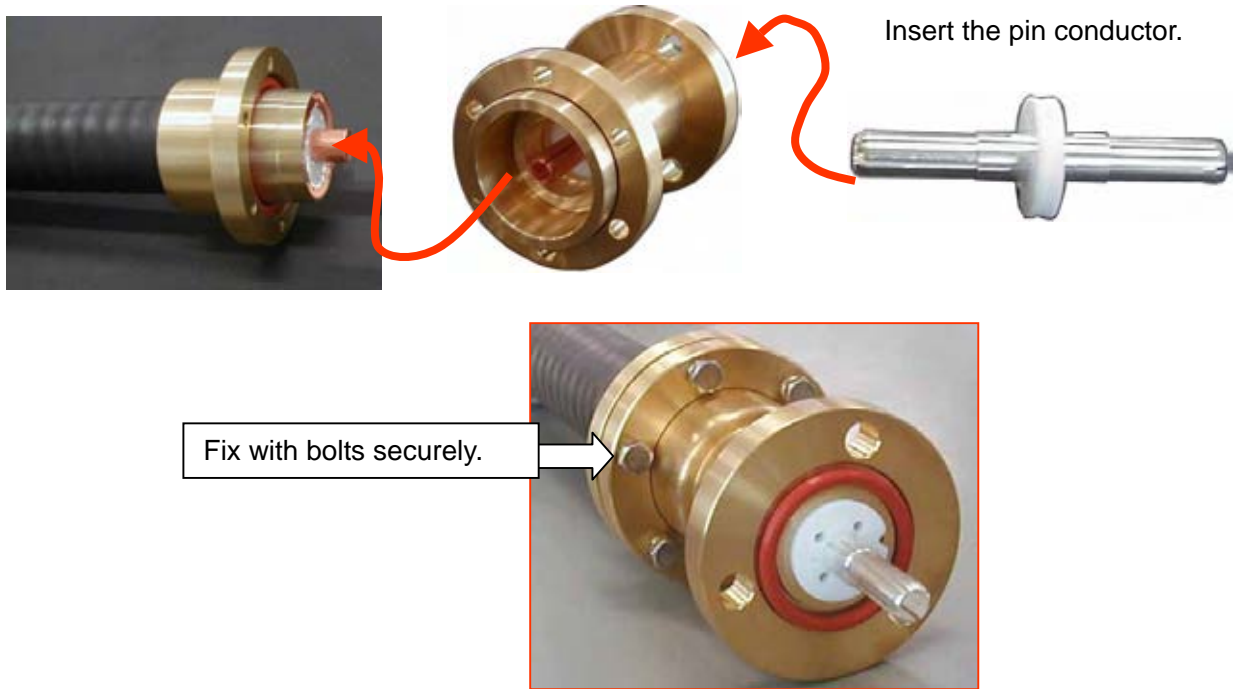

Fig.1.3.20 Fabricating coaxial cable-5

6. Tape

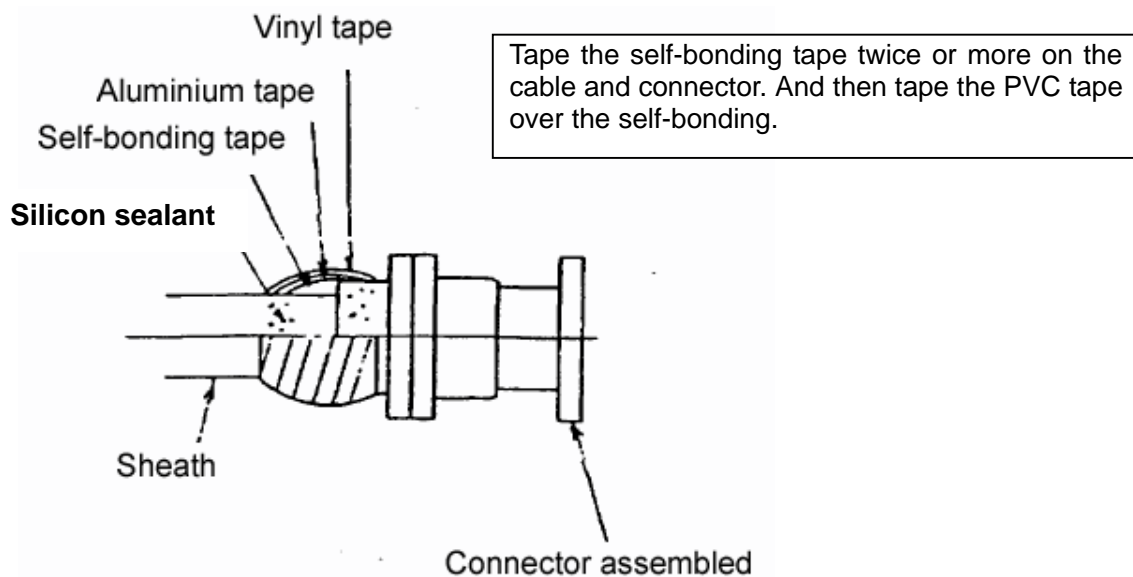
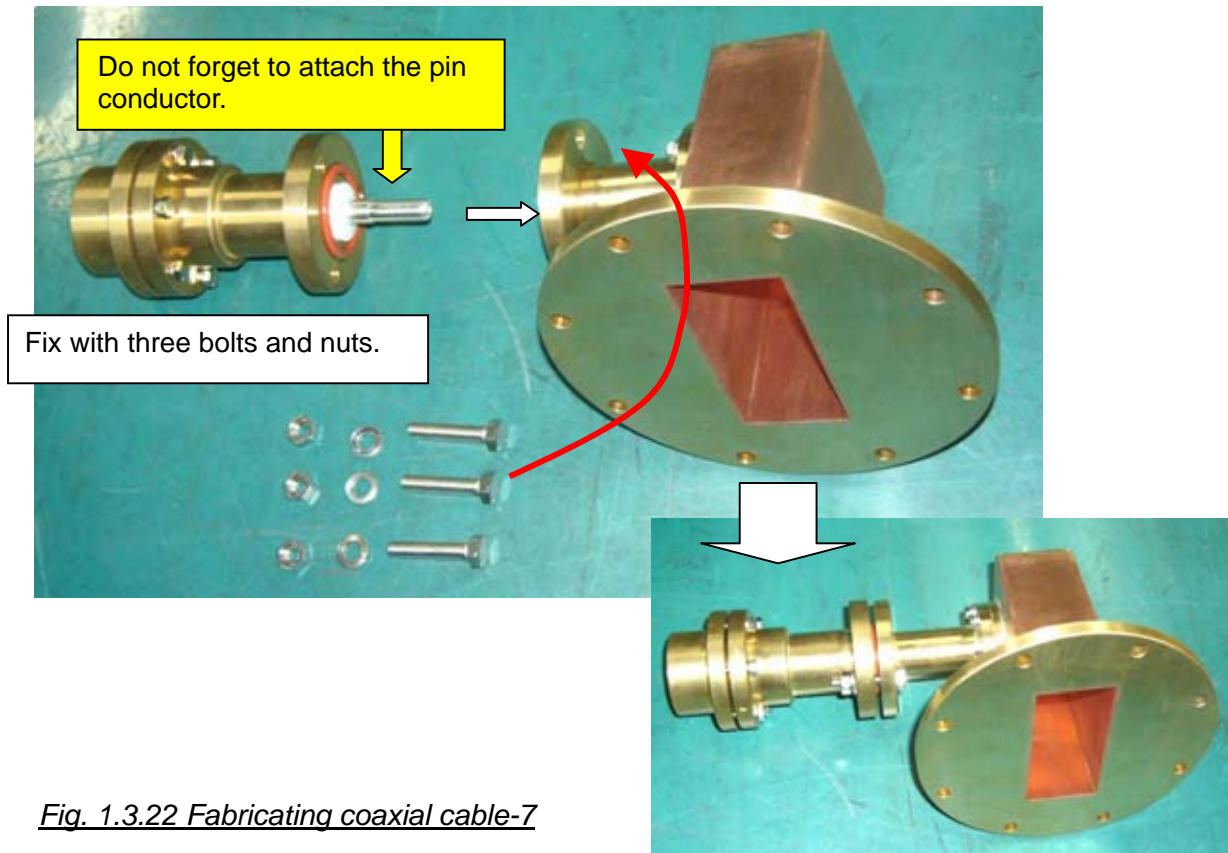
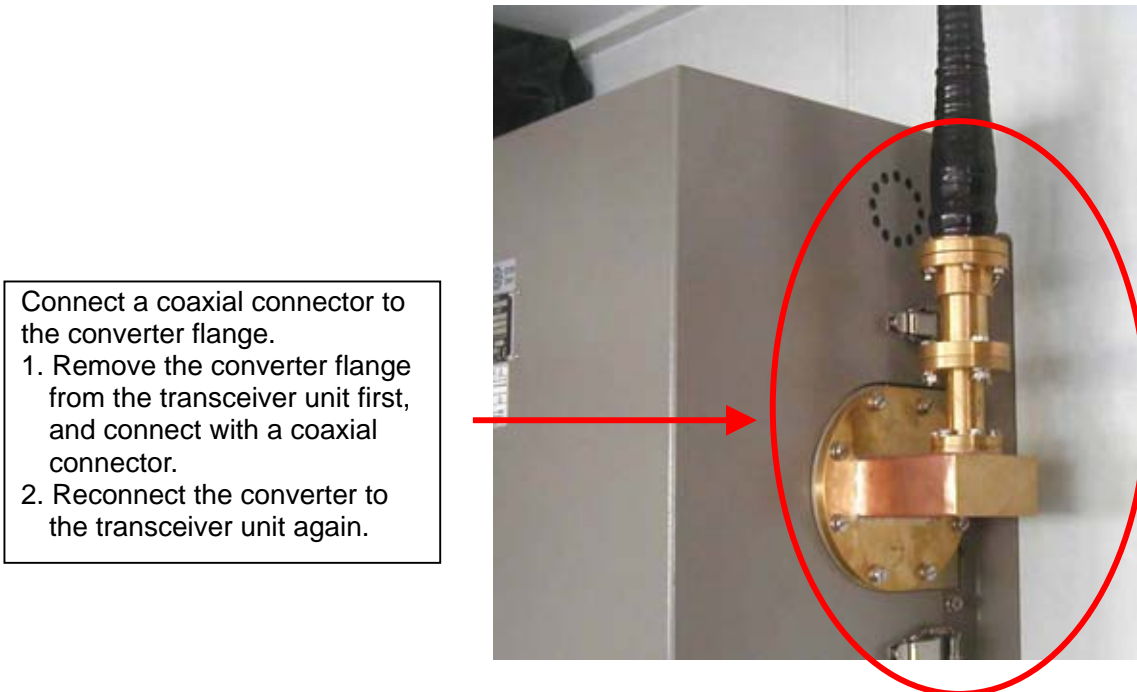

Fig. 1.3.21 Fabricating coaxial cable-6

7. Assemble S-band coaxial connector and connector converter



8. Fabricate the coaxial connector and converter



Tools for fabricating the S-band coaxial connector

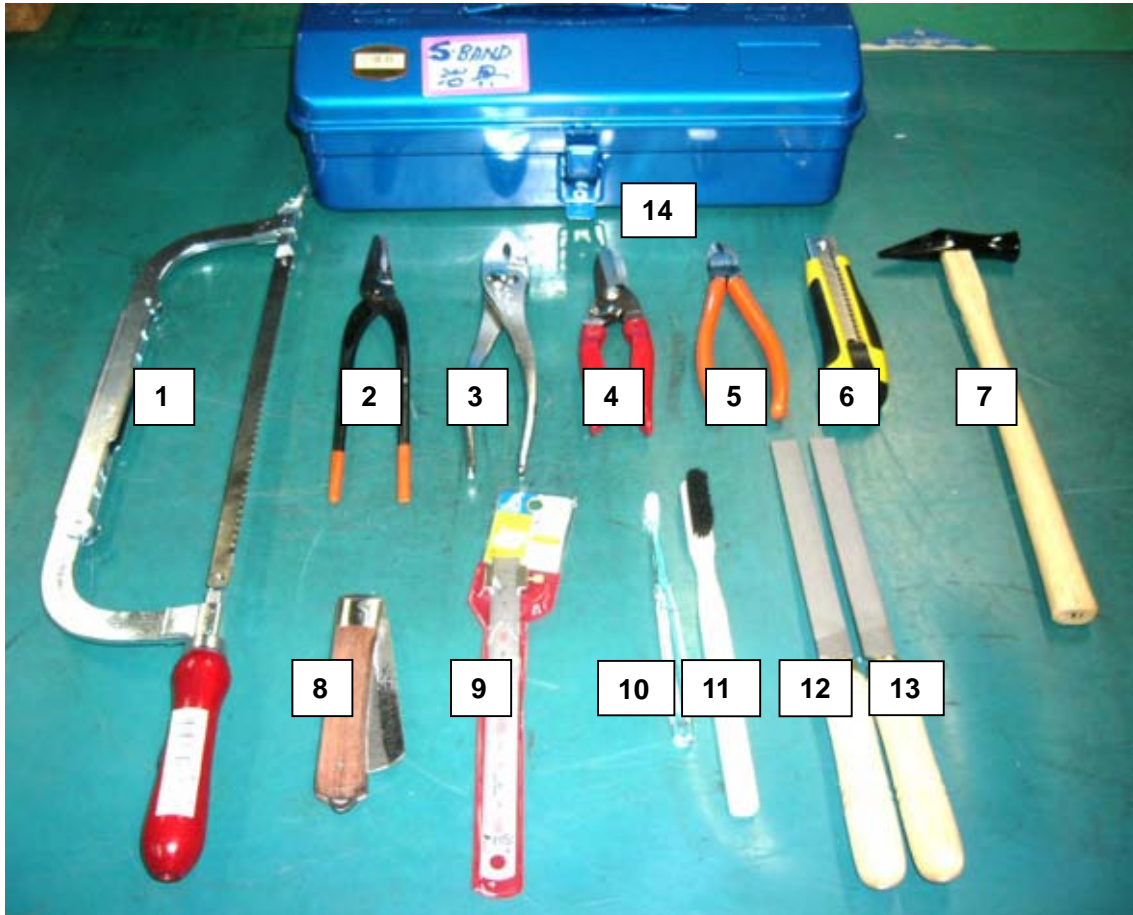

Fig. 1.3.24 Tools for fabricating S-band coaxial connector

Table 1.3.1 Tools

No.	Name	Type	No.	Name	Type
1	Hack-saw	HFJ-12	8	Knife	DK-N
2	Pincers	220 mm	9	Bench rule with stopper	150 mm
3	Plier	PL-200	10	Brush	Small
4	Snips	170 mm	11	Brush	Medium
5	Nipper	70-150	12	File	Fine
6	Knife	LDS-20-028	13	File	Second-cut
7	Hammer	18 mm	14	Tool Box	Y-350

1.4 Installation of Radar Console



Fig. 1.4.1 Installation of two-radar consoles

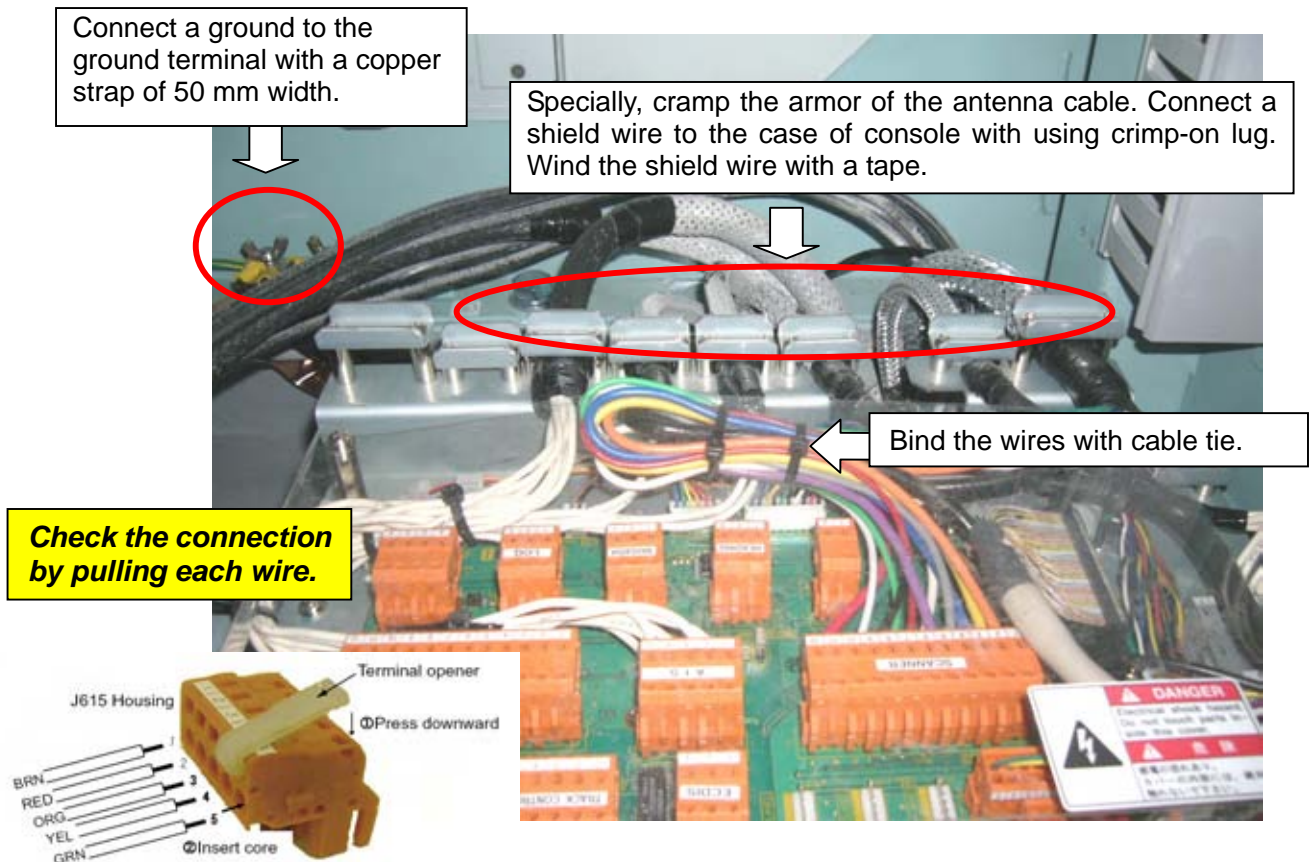

Fig. 1.4.2 Wiring in the console

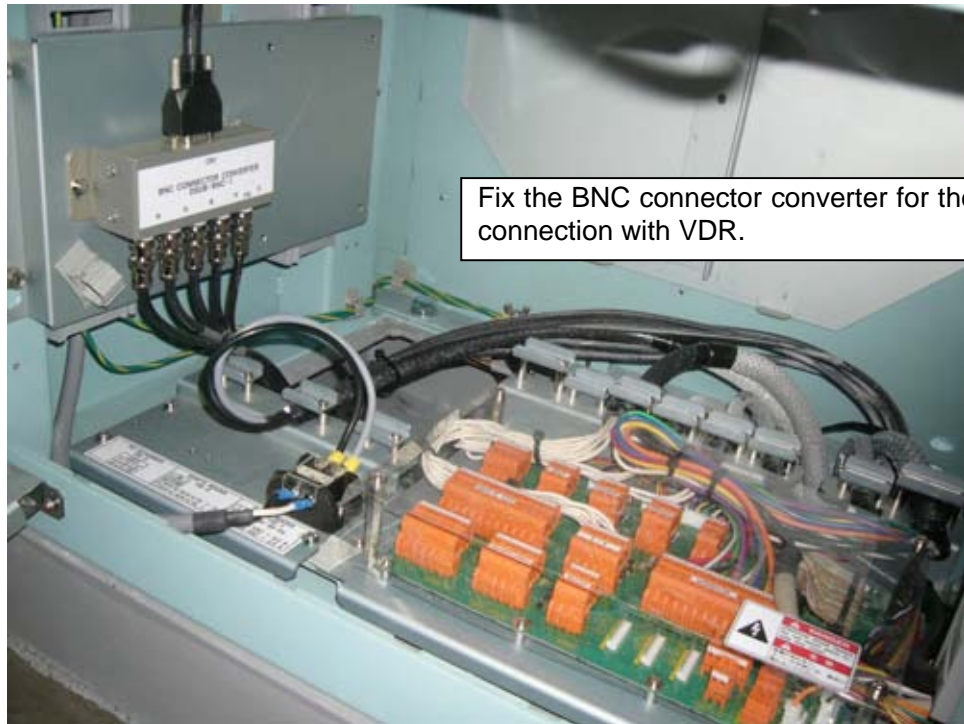

Fig. 1.4.3 Fixing BNC connector converter

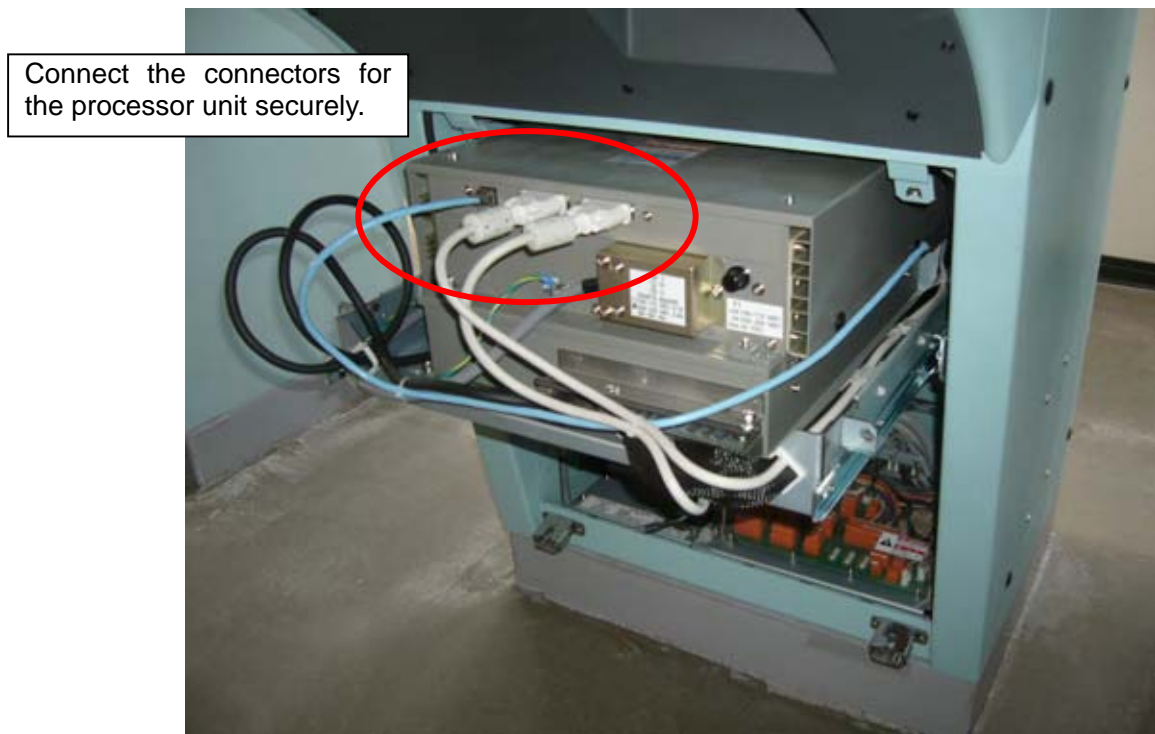

Fig. 1.4.4 Connection for the processor unit

Connection of LAN cable

Use a cross-cable between FAR and FAR, and between FAR and CU-200. Since the HUB-100 automatically distinguishes the difference of cable with All Port Auto MDIX function, when connecting them through the HUB-100, either cable can be used. The cable type must be above category five.

Pairs	Pin No.	Signal	Straight Cable		Cross Cable	
			Pin No.	Signal	Pin No.	Signal
1-2	1 (WHT-GRN)	TXP	1 (WHT-GRN)	TXP	1 (3. WHT-ORG)	RXP
	2 (GRN)	TXN	2 (GRN)	TXN	2 (6. GRN)	RXN
3-6	3 (WHT-ORG)	RXP	3 (WHT-ORG)	RXP	3 (1. WHT-GRN)	TXP
4-5	4 (WHT-BLU)	NC	4 (WHT-BLU)	NC	4 (4. WHT-BLU)	NC
	5 (BLU)	NC	5 (BLU)	NC	5 (5. BLU)	NC
3-6	6 (ORG)	RXN	6 (ORG)	RXN	6 (2. GRN)	TXN
7-8	7 (WHT-BRN)	NC	7 (WHT-BRN)	NC	7 (7. WHT-BRN)	NC
	8 (BRN)	NC	8 (BRN)	NC	8 (8. BRN)	NC

Fabrication of LAN cable

1. Cut wires remaining length of 11 mms. Cut the shield and drain wires remaining 9 mms after turning up.
2. Insert wires into plug housing neatly side by side, so that the tip of each wire cab is seen at the end of housing. A drain wire is set to tab side.
3. Clamp with crimp tool.

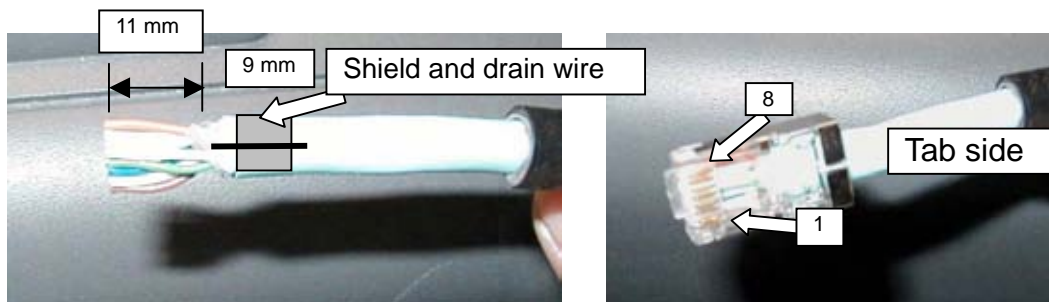

Clamp with crimp tool.

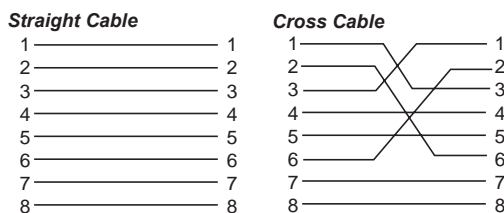

Fig. 1.4.5 Fabrication of LAN connector

2.1 Installation of ECDIS Console

2.1.1 Mounting of ECDIS console

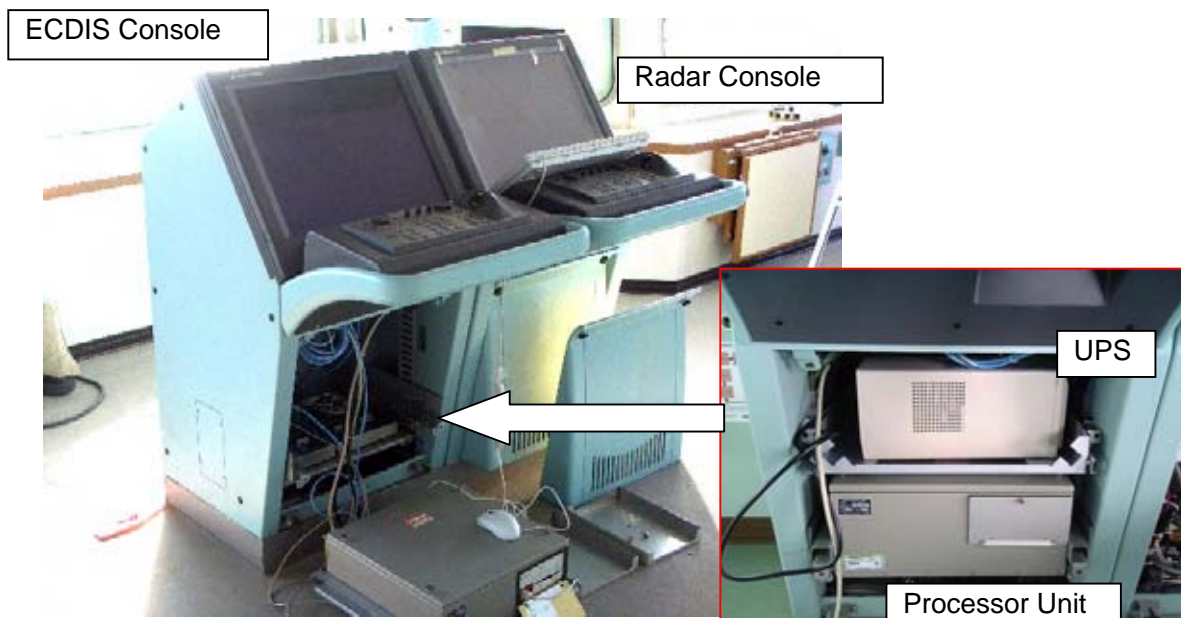

Fig. 2.1.1 Standard console of Radar and ECDIS; ECN-003



Fig. 2.1.2 Slim-type Radar and ECDIS console; ECN-001

2.1.2 Wiring of ECDIS console

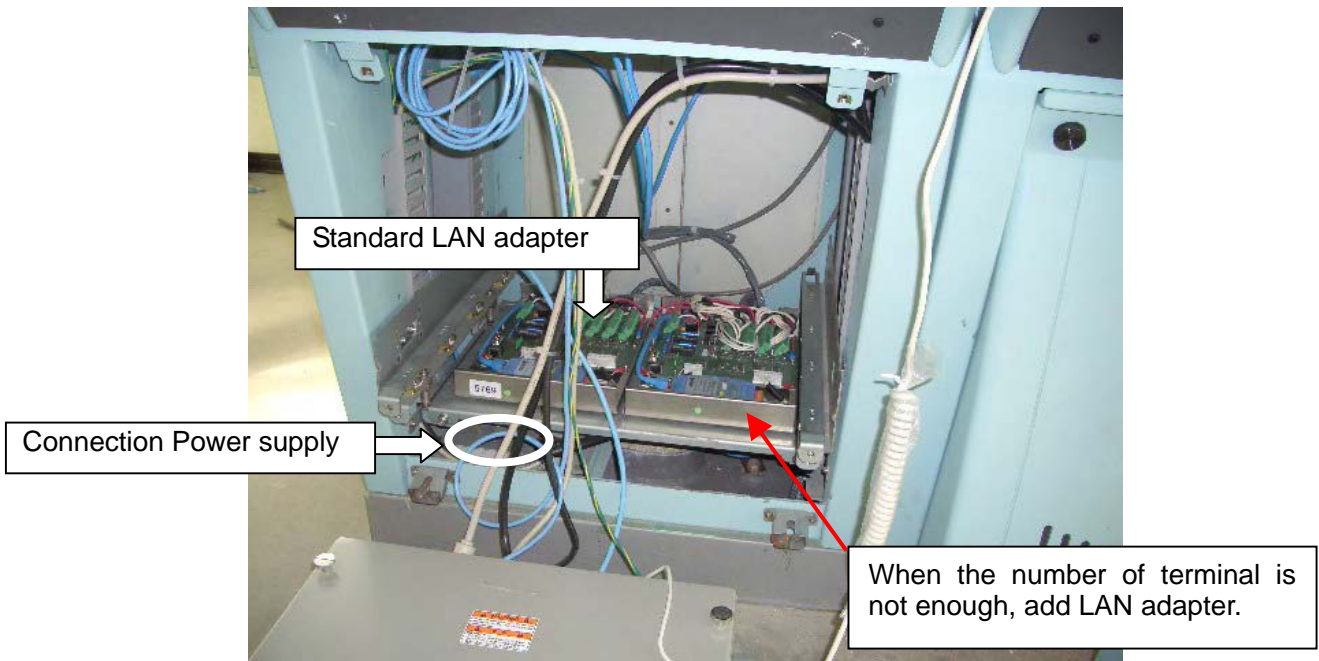

Fig. 2.1.3 Wiring to LAN adapter

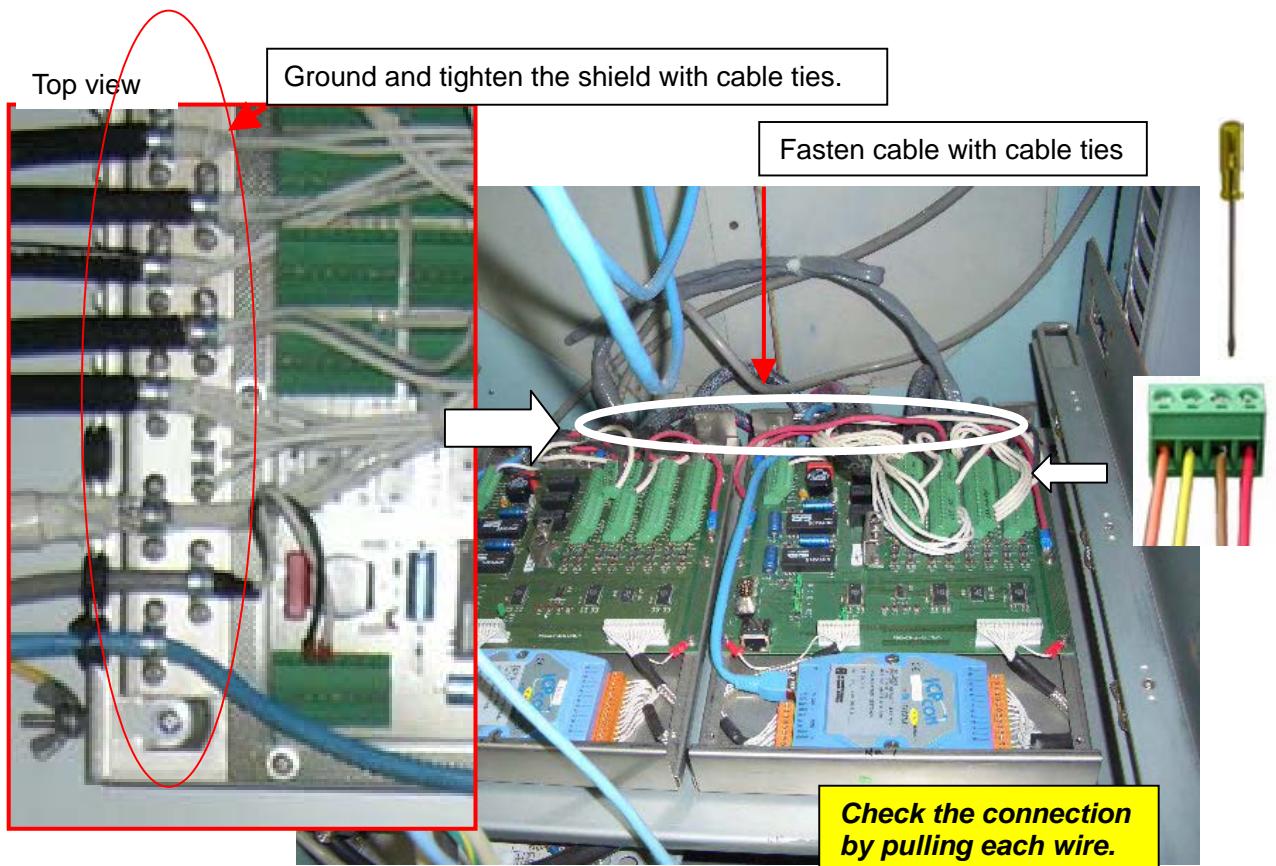

Fig. 2.1.4 Connection of LAN adapter

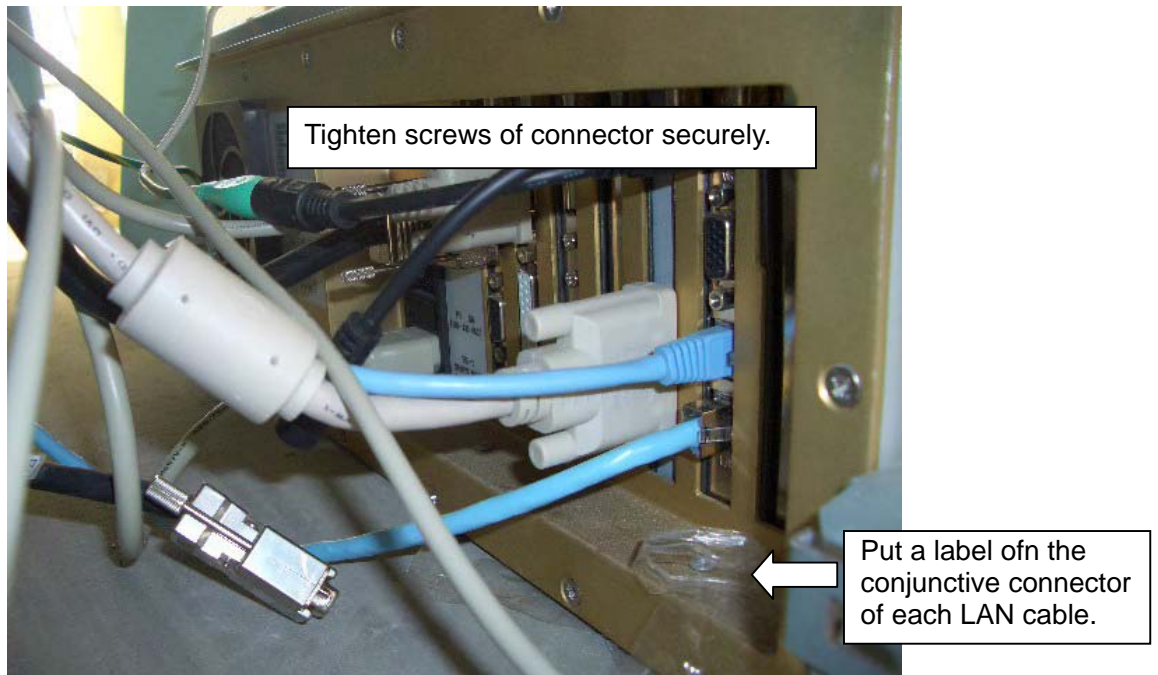
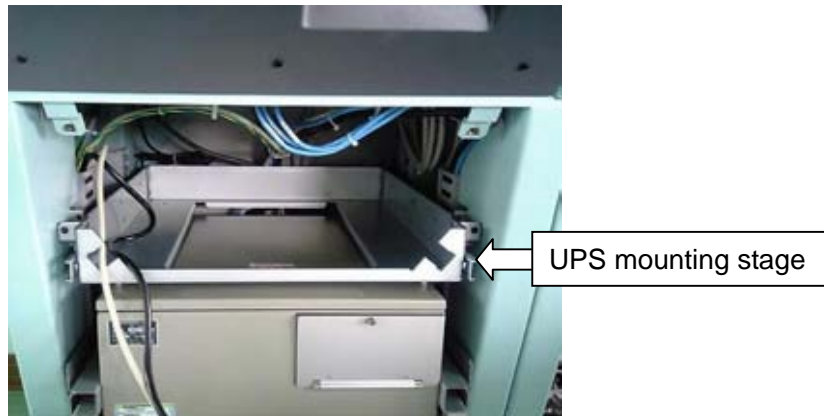

Fig. 2.1.5 Connection of processor unit

1. Installation of UPS (uninterruptible power source)



Type: -196 Code No:1-050

Name	Type	Code No.	Qty	Remarks
Hex. Bolt	M6x12	000-808-428	10	
Pan Head Screw	M4x8 SUS304	000-801-137	24	
Slide rail	3504-18	000-150-514	1 set	For left and right sides, 2 pcs.
Processor Unit Plate	03-163-7212-3	100-320-753	1	
Rail guide (1L)	03-163-7209-2	100-320-732	1	
Rail guide (1R)	03-163-7208-2	100-320-722	1	
Rocking edge saddle	LES-2017	000-809-398	2	

Procedure

1. Separate outer and inner plates of the slide rails as below.

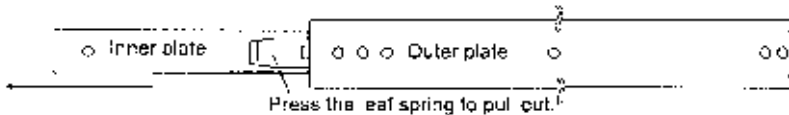

2. Attach two locking edge saddles to the processor unit plate as shown below.
3. Fasten 10 pan-head-screws to attach two inner plates of slide rails to both sides of the processor unit plate.

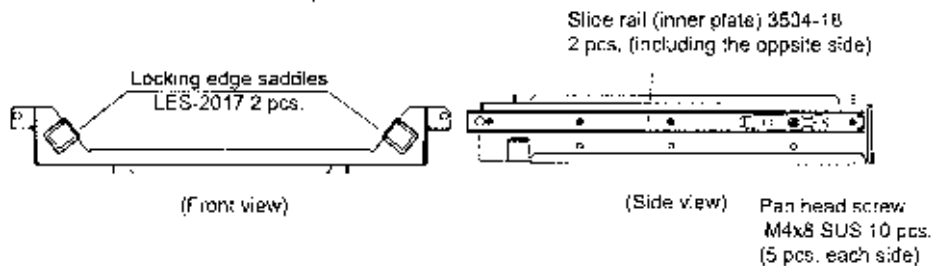

4. Unfasten two knob bolts to remove the front cover from the console.

- Attach the outer plate of the slide rail (removed at step 1) to the rail guide with 14 pan-head-screws as below. Do this for both left and right sides.

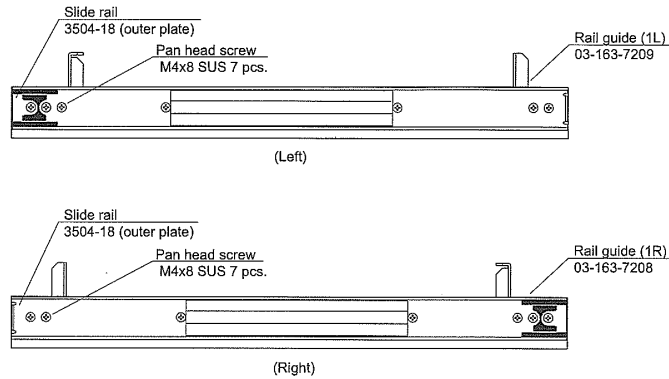

- Fasten 8 hex. bolts (M6x12) to attach rail guides (assembled at step 5) to both sides in the console.

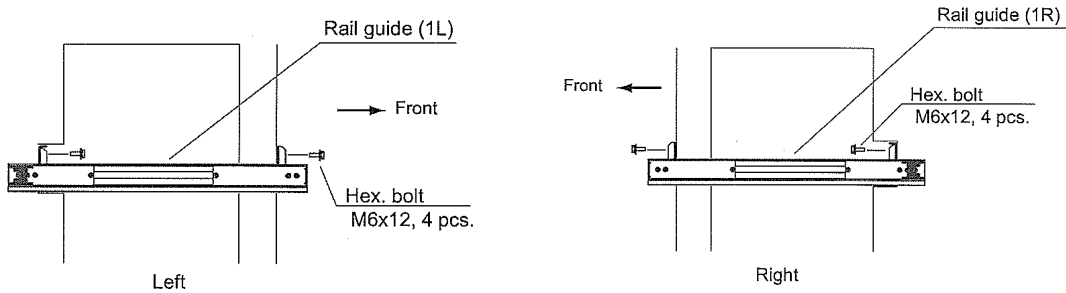

- Keep the processor unit plate assembled at steps 2 and 3 horizontally, and push it until it contacts the springs.
- Press the leaf springs of the left and right rails with finger to enable further push-in.

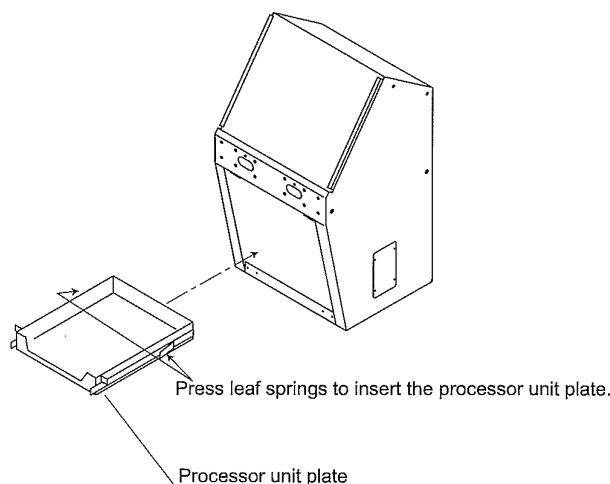

- Push the processor unit plate into the back of the console, and then fix it with 2 hex. bolts (M6x12).
- Re-attach the front cover to the console.

On the production in 2006, Feb. and after.

Fix the UPS on the mounting stage with fixture by processing in local.

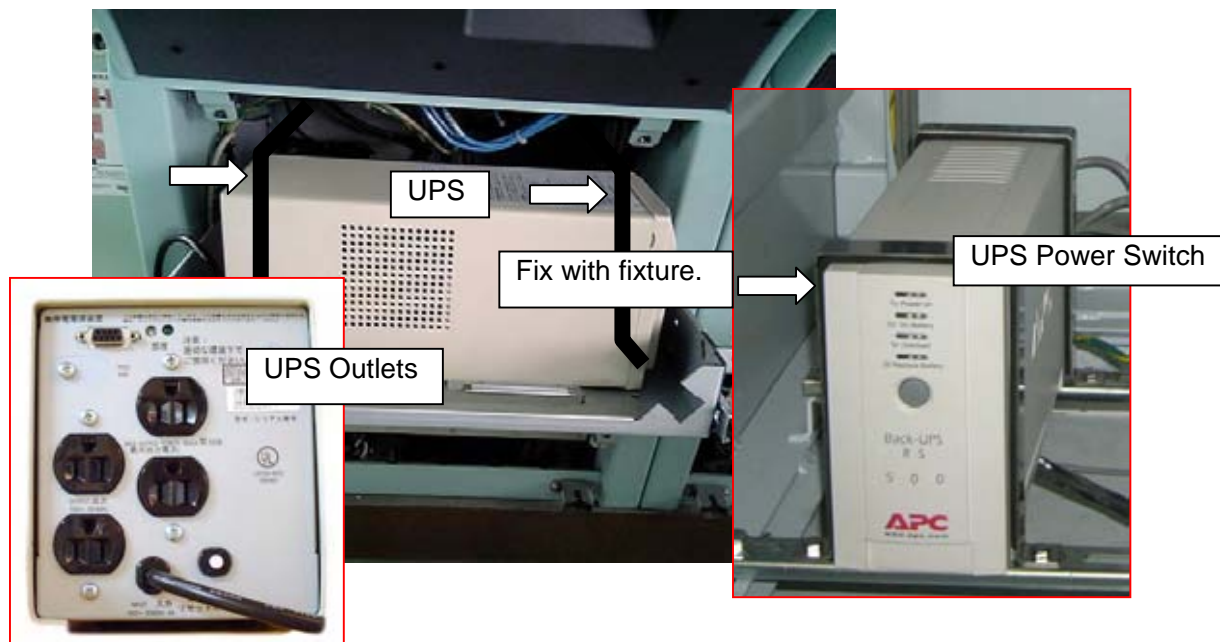

Fig. 2.1.6 Fixing UPS

2. Check Specification of power supply (PR-62) of LAN adapter.

HUB-100
The cable between LAN adapter and HUB is standard supply.
The cable "straight cable" between HUBs are required to fabricate in the field.

Check input voltage on the label of the PR-62 is correct.

PR-62:
Power Supply for LAN adapter

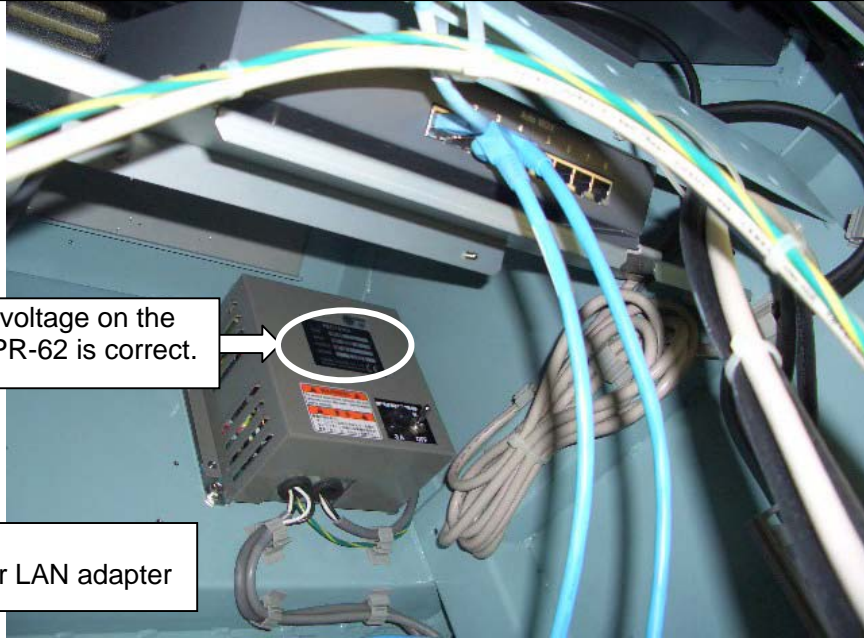
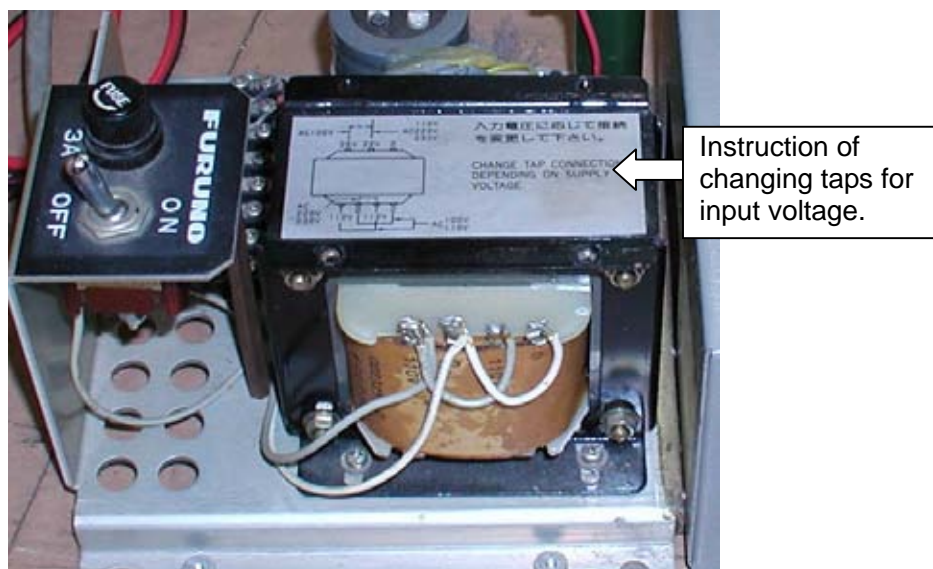

Fig. 2.1.7 Power supply of LAN adapter

Changing taps of transformer of PR-62.



Instruction of changing taps for input voltage.

Fig. 2.1.8 Changing taps of PR-62

3. Improper Installation

Do not install the processor unit in the place where does not have ventilation, such as in a storage place. The temperature of the above mentioned place increase improperly, particularly in the summer, and cause malfunctions of the processor unit. When installing to the closed area, equip ventilation in there.

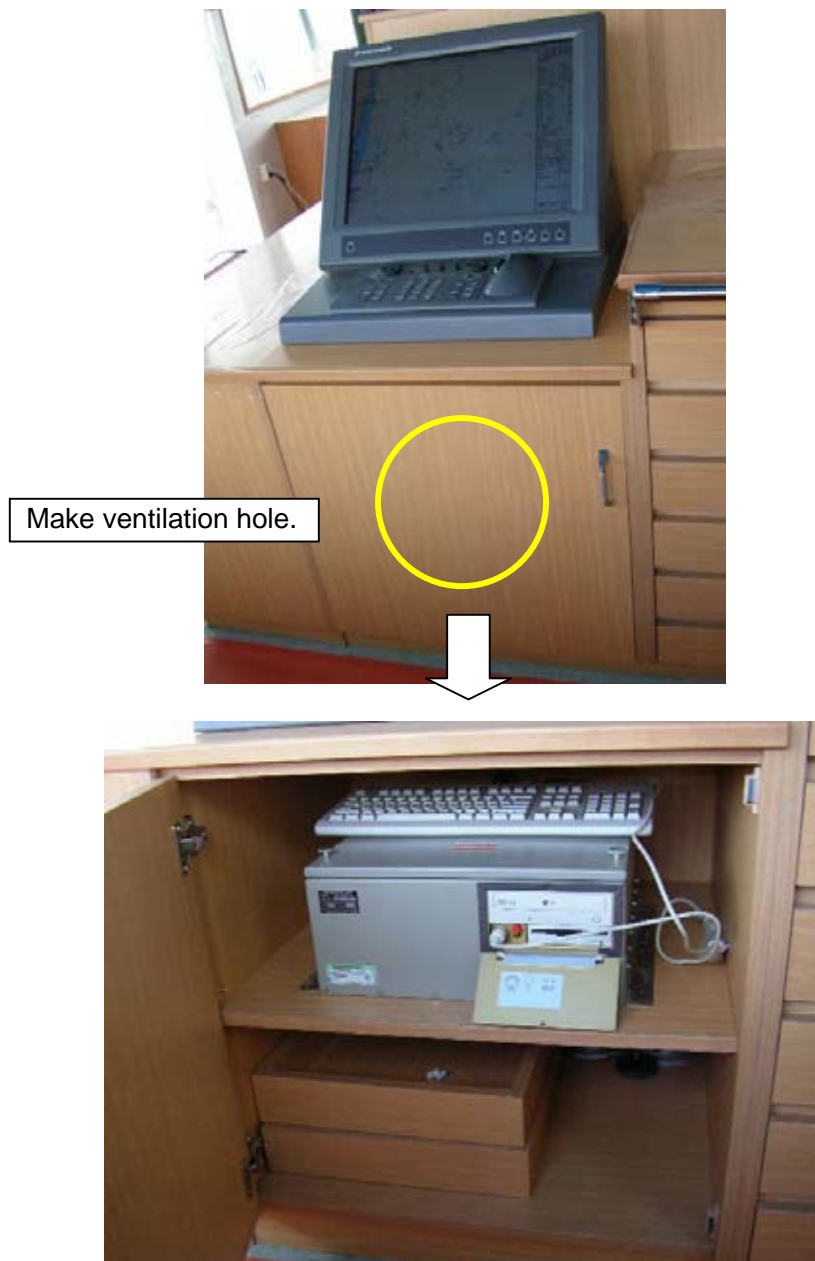

Fig. 2.1.9 Improper location of the processor unit

Connection of LAN cable

Use a cross-cable between the EC-1000C and EC-1010. Since the HUB-100 automatically distinguishes the difference of cable with All Port Auto MDIX function, when connecting them through the HUB-100, either cable can be used,. The cable type must be above category five.

Pairs	Pin No.	Signal	Straight Cable		Cross Cable	
			Pin No.	Signal	Pin No.	Signal
1-2	1 (WHT-GRN)	TXP	1 (WHT-GRN)	TXP	1 (3. WHT-ORG)	RXP
	2 (GRN)	TXN	2 (GRN)	TXN	2 (6. GRN)	RXN
3-6	3 (WHT-ORG)	RXP	3 (WHT-ORG)	RXP	3 (1. WHT-GRN)	TXP
4-5	4 (WHT-BLU)	NC	4 (WHT-BLU)	NC	4 (4. WHT-BLU)	NC
	5 (BLU)	NC	5 (BLU)	NC	5 (5. BLU)	NC
3-6	6 (ORG)	RXN	6 (ORG)	RXN	6 2. (GRN)	TXN
7-8	7 (WHT-BRN)	NC	7 (WHT-BRN)	NC	7 (7. WHT-BRN)	NC
	8 (BRN)	NC	8 (BRN)	NC	8 (8. BRN)	NC

Fabrication of LAN cable

1. Cut wires remaining length of 11 mms. Cut the shield and drain wires remaining 9 mms after turning up.
2. Insert wires into plug housing neatly side by side, so that the tip of each wire cab is seen at the end of housing. A drain wire is set to tab side.
3. Clamp with crimp tool.



Clamp with crimp tool.

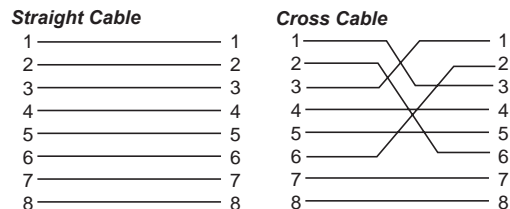

Fig. 2.1.10 Fabricating LAN connector

2.2 Custom Ordered Console

2.2.1 Installation

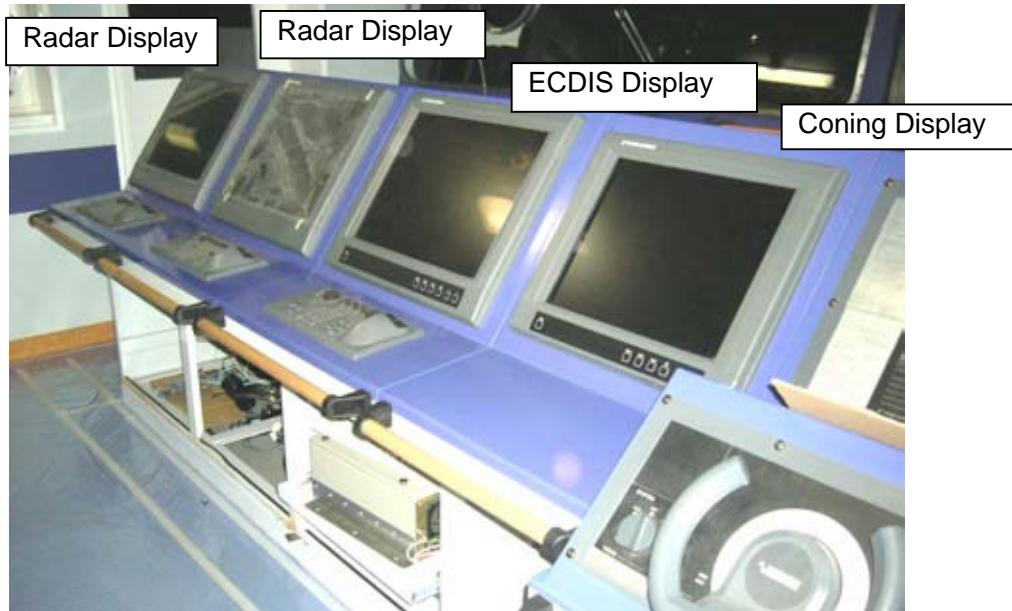

Fig. 2.2.1 Installation of custom ordered console

2.2.2 Wiring of Console

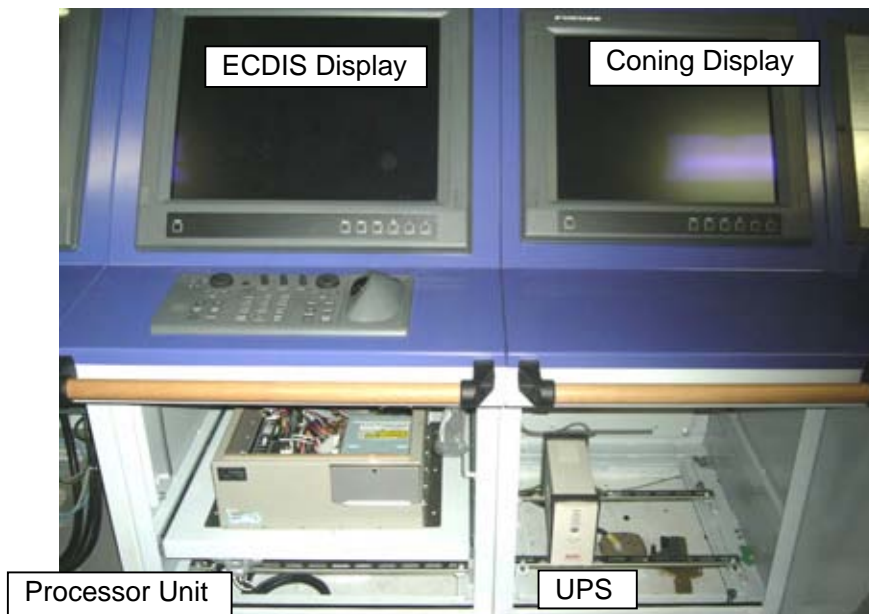

Fig. 2.2.2 Processor unit and UPS ECDIS

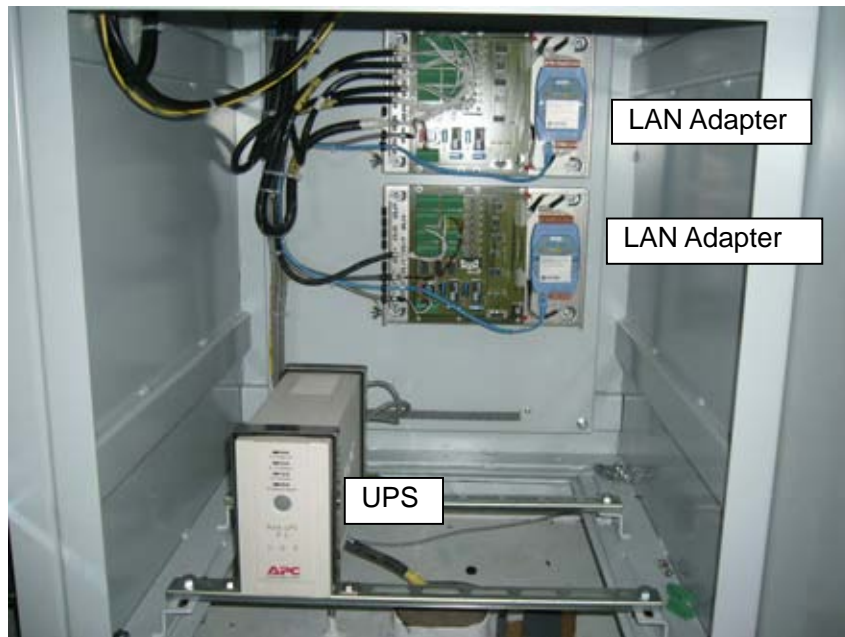

Fig. 2.2.3 Wiring for LAN adapter

1. Wiring for LAN adapter

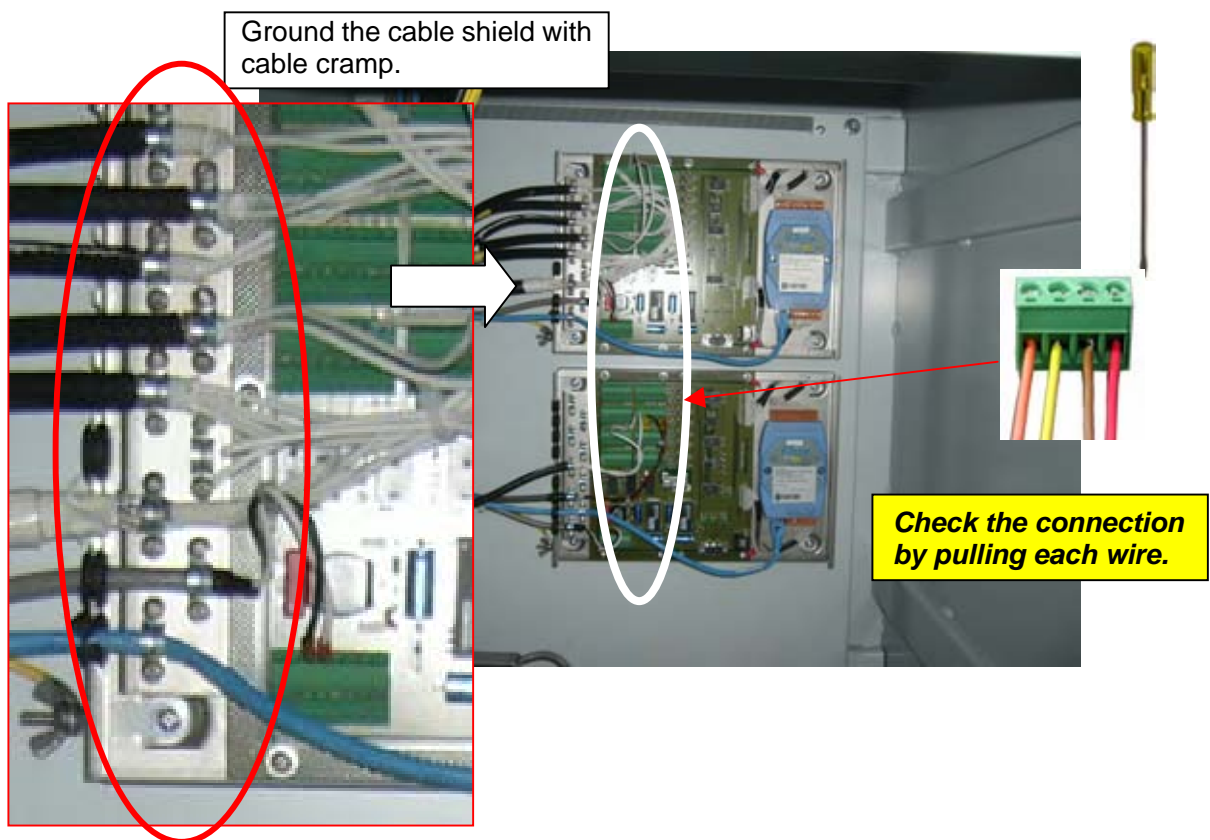
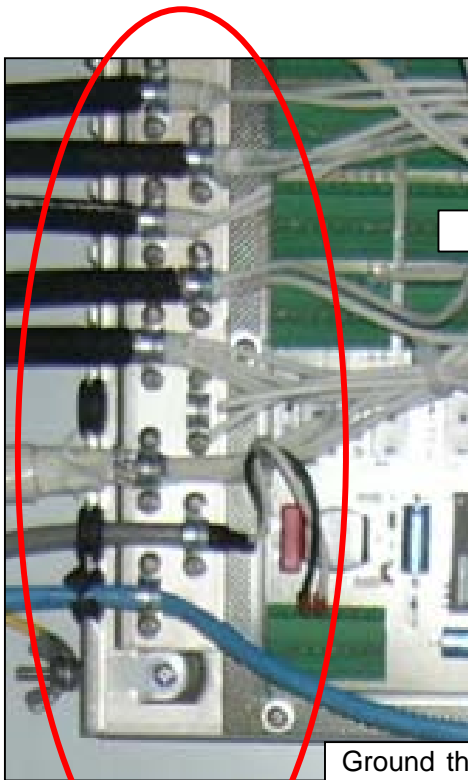

Fig. 2.2.4 Wiring for LAN adapter

2. Wiring for B adapter



Install B adapter behind of the coning display.



Ground the cable shield with cable clamp.



Check the connection by pulling each wire.

Fig. 2.2.5 Wiring for B adapter

3. Wiring for HUB unit



Install HUB behind of the ECDIS display.



Power of HUB and PR-62 are supplied by the UPS.



PR-62; Power supply for LAN adapter and B adapter.

Confirm that input voltage shown on the label is the same as the output voltage of the UPS.

Attach the tag which display the counter part of connection to LAN cables.

HUB-100
The cable connectors between LAN adapter and HUB have been fabricated in the factory. LAN cable Connectors between radar and HUB must be fabricated in the field.

Fig. 2.2.6 Wiring for HUB unit

2.3 Connection of EXT. Monitor for ECDIS

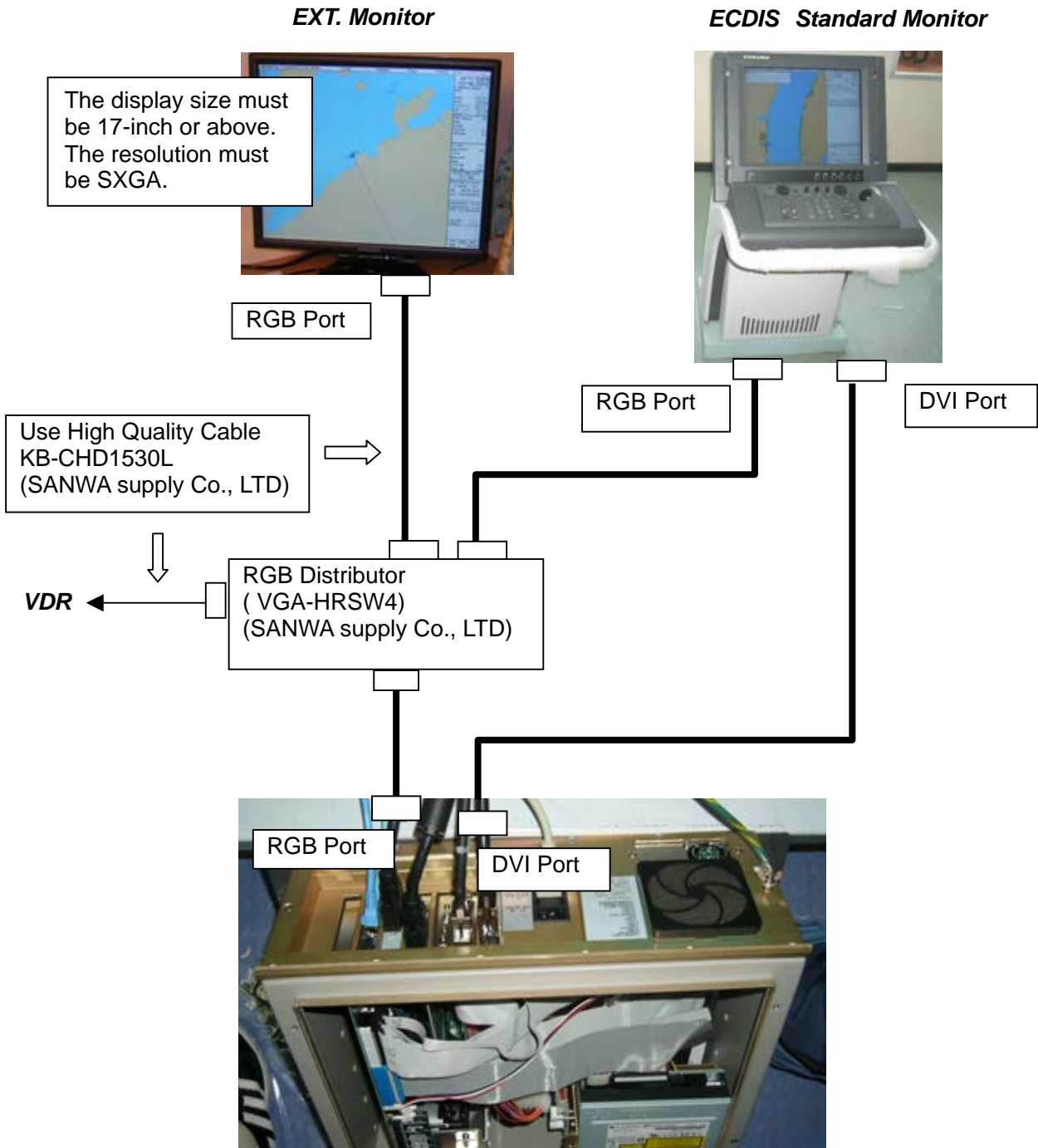

Fig. 2.3.1 Connection of external monitor

RGB distributor

Recommendation: VGA-HRSW4 (SANWA supply)



Fig. 2.3.2 RGB distributor "VGA-HRSW4"(SANWA Supply)

High quality cable

Recommendation: KB-CHD1530L (SANWA Supply).



Fig. 2.3.3 High quality cable KB-CHD1530L (SANWA Supply)

3.1 Installation of MF/HF Antenna No.1 (Indoor installation of Antenna coupler)

3.1.1 Mounting of Antenna

In the shipyard, put red clothes to the antenna wire for calling the crane operator's attention.



Fig. 3.1.1 Measure of safety

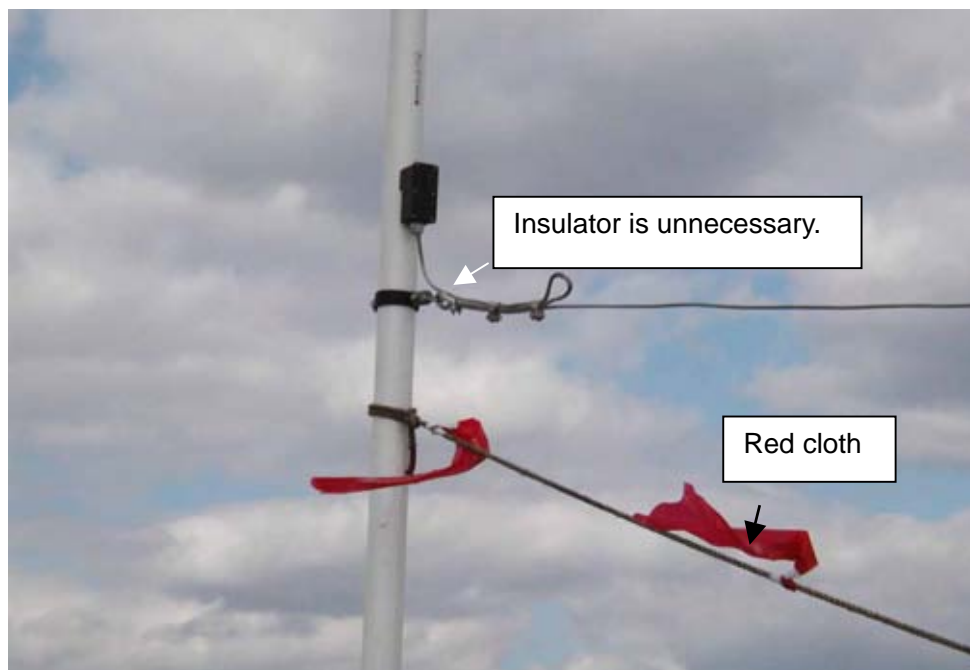

Fig. 3.1.2 Connection of antenna feeder

1. Antenna feeder

Use a support wire to reinforce the feeder.

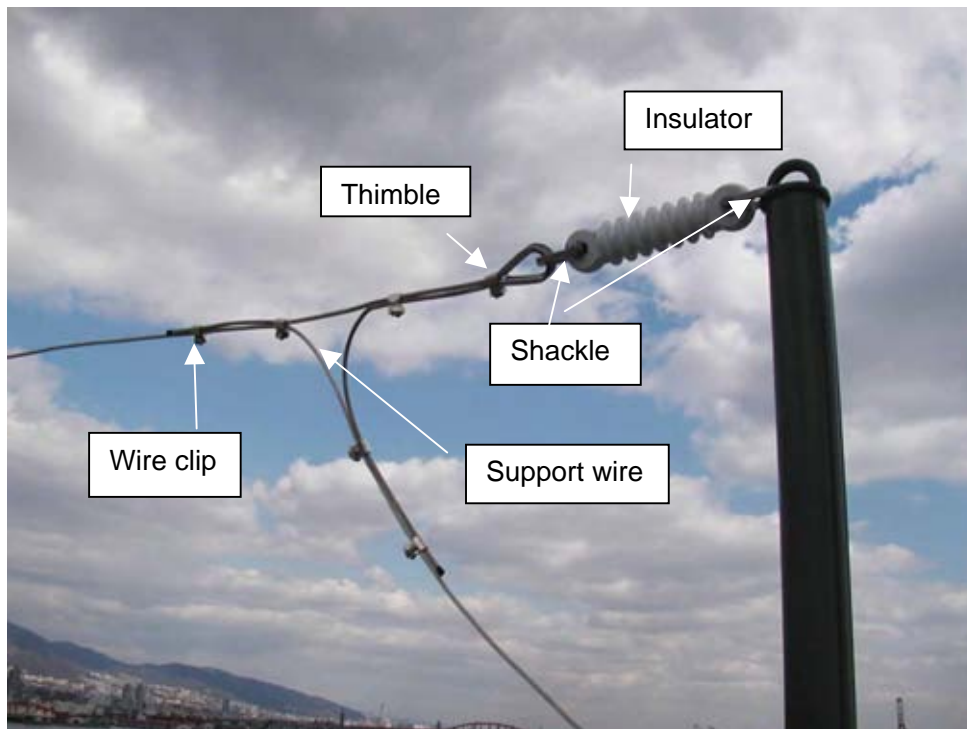

Fig. 3.1.3 Antenna feeder

Fix the feeder with an insulator.

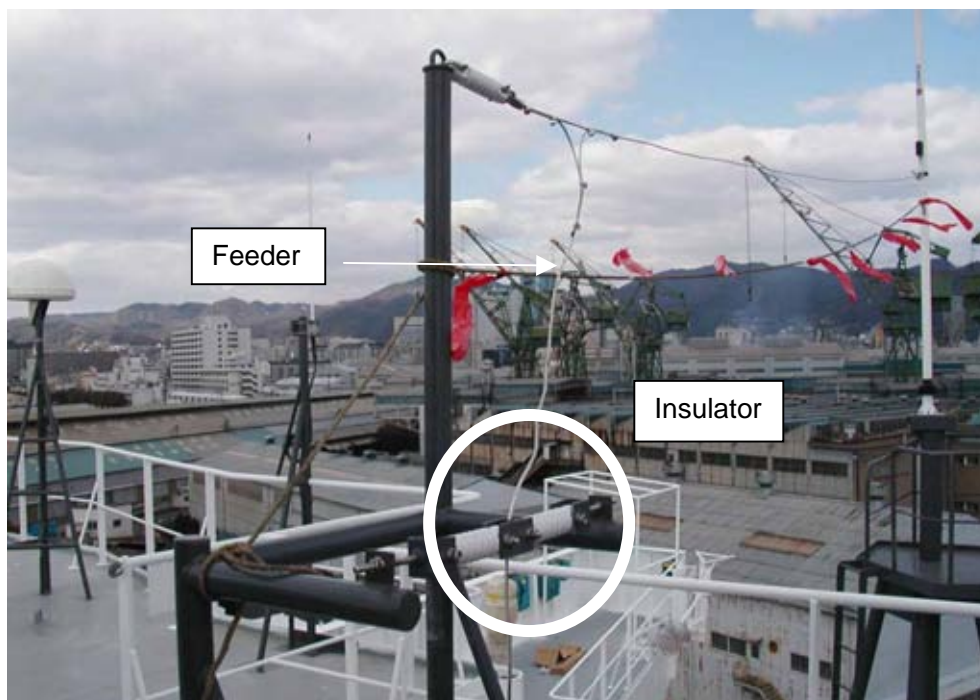

Fig. 3.1.4 Fixing feeder

2. Lead-in insulator

Use lead-in insulator to lead the feeder into the radio room (indoor).

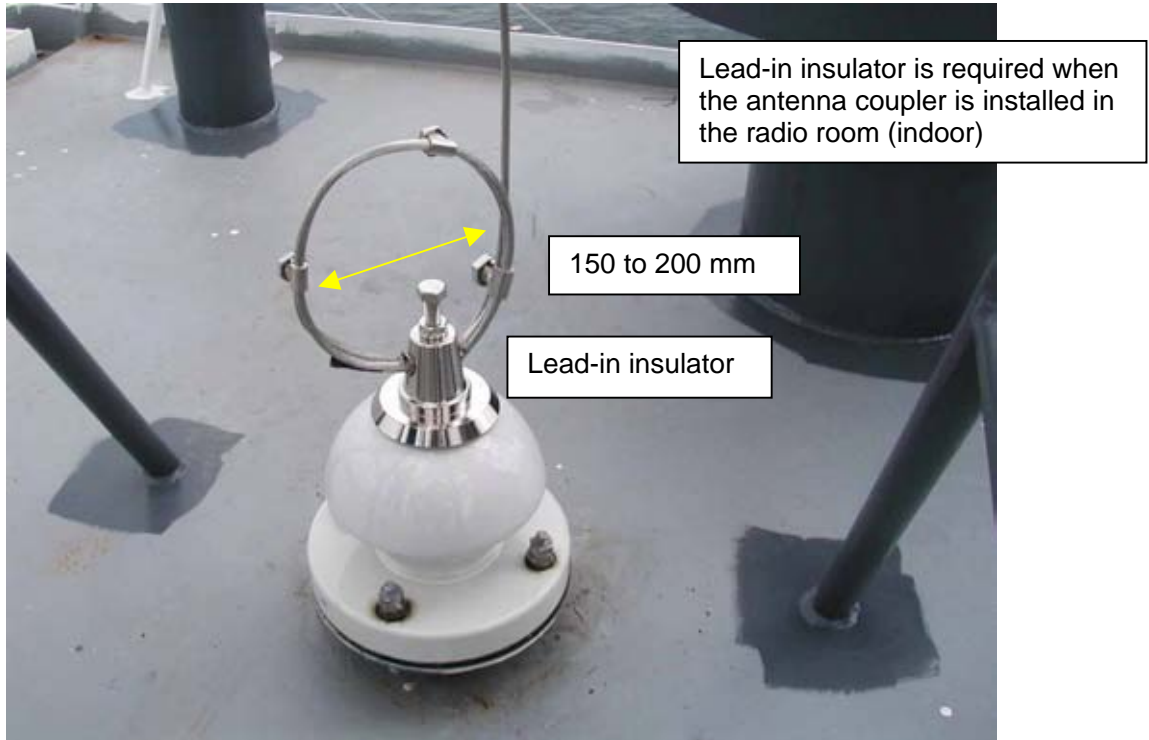

Fig. 3.1.5 Mounting of Antenna lead-in insulator

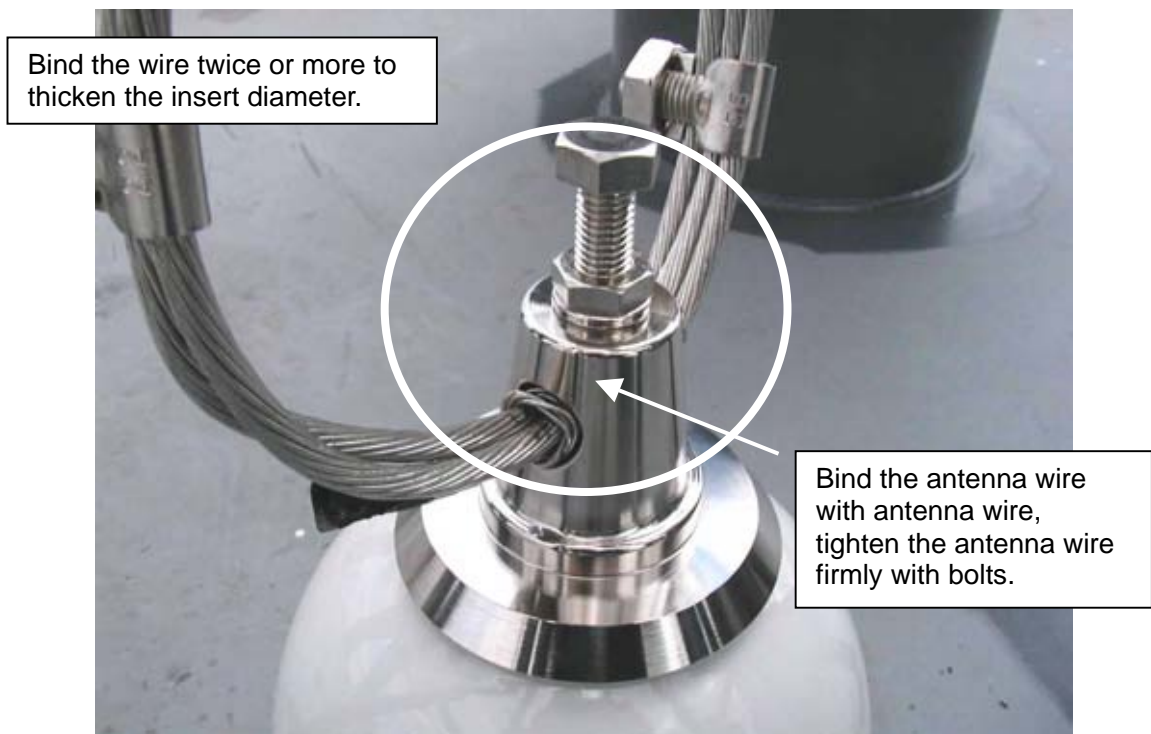
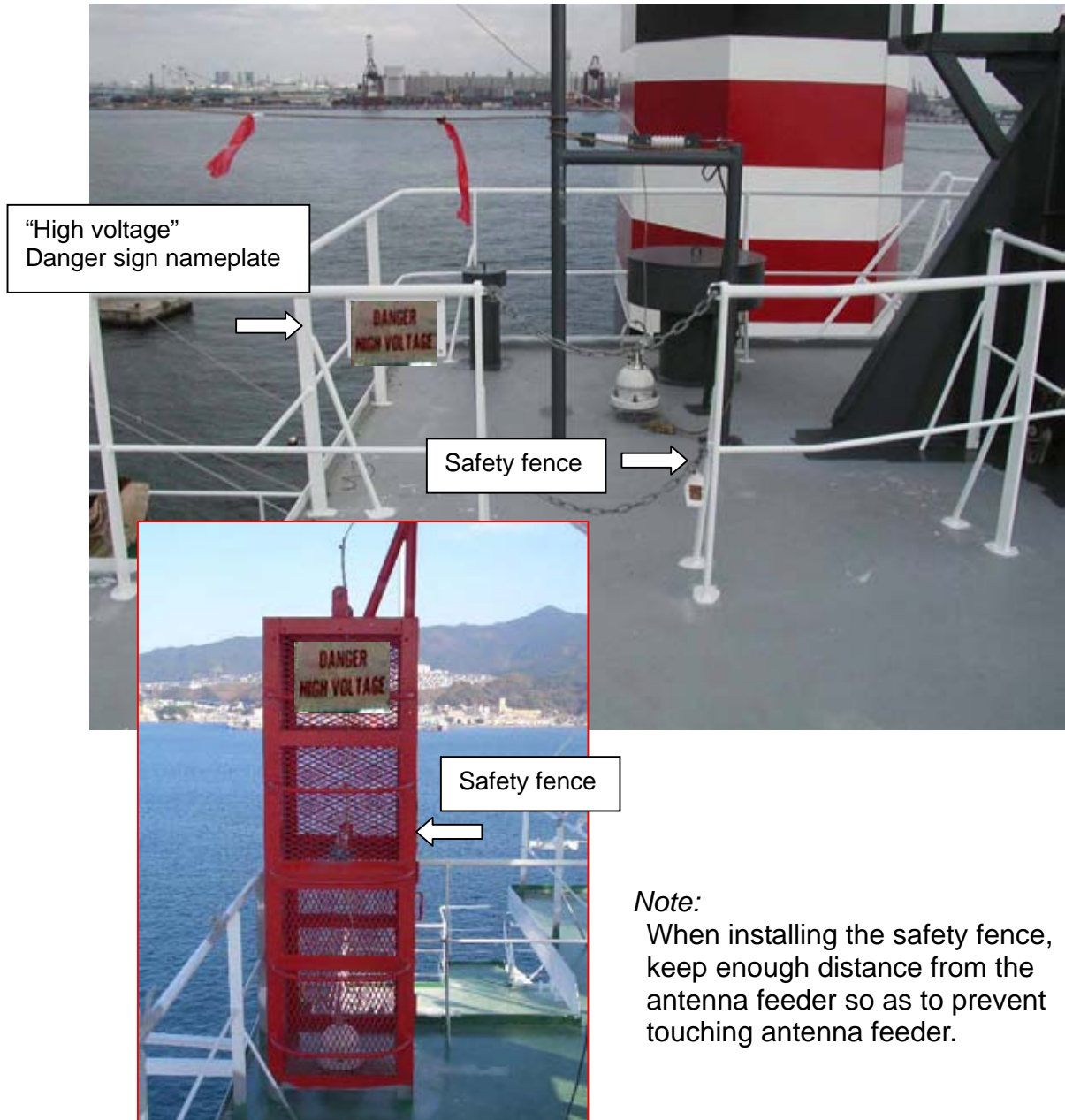

Fig. 3.1.6 Fixing antenna wire

3. Mounting of safety fence

Arrange the safety fence to separate the antenna feeder from crews, and put the danger sign at the entry.



Note:
When installing the safety fence, keep enough distance from the antenna feeder so as to prevent touching antenna feeder.

Fig. 3.1.7 Arrangement of safety fence

3.1.2 Mounting of Antenna coupler

1. Indoor feed line

Connect between the lead-in insulator and antenna coupler by a copper pipe. The pipe is fixed with using stand insulators. The ANT changeover is installed for the protection from lightning, and also for prohibiting the transmission in harbor.

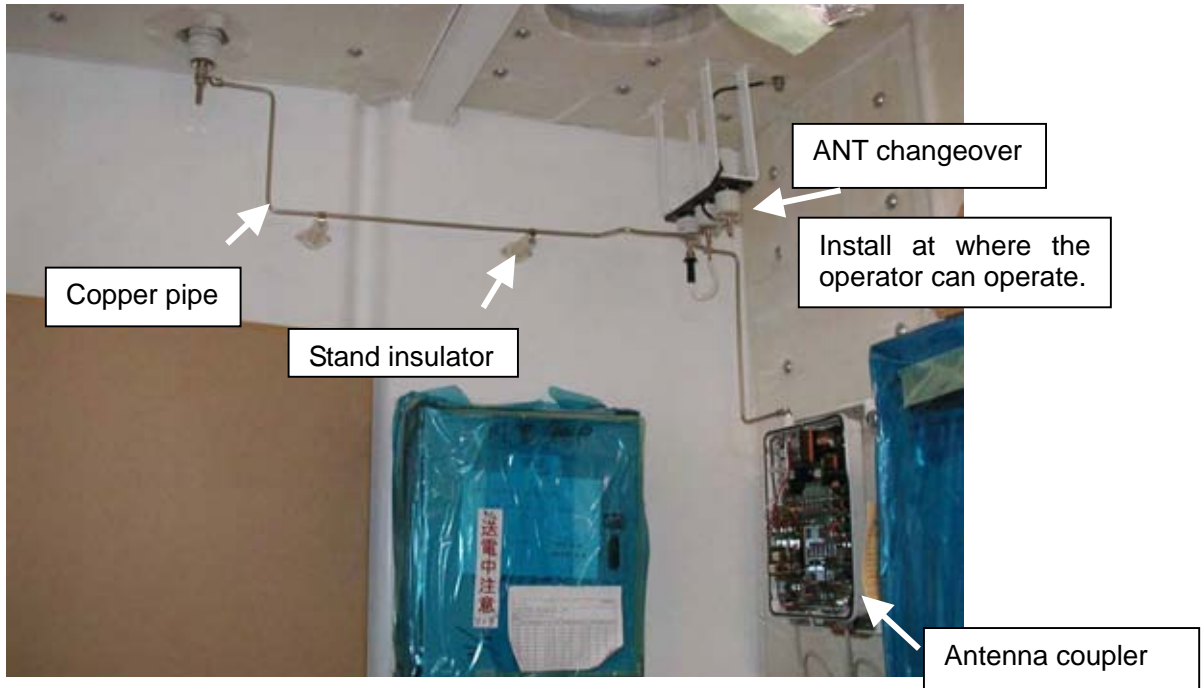

Fig. 3.1.8 Indoor feed line

The antenna changeover is installed for lightning protection.

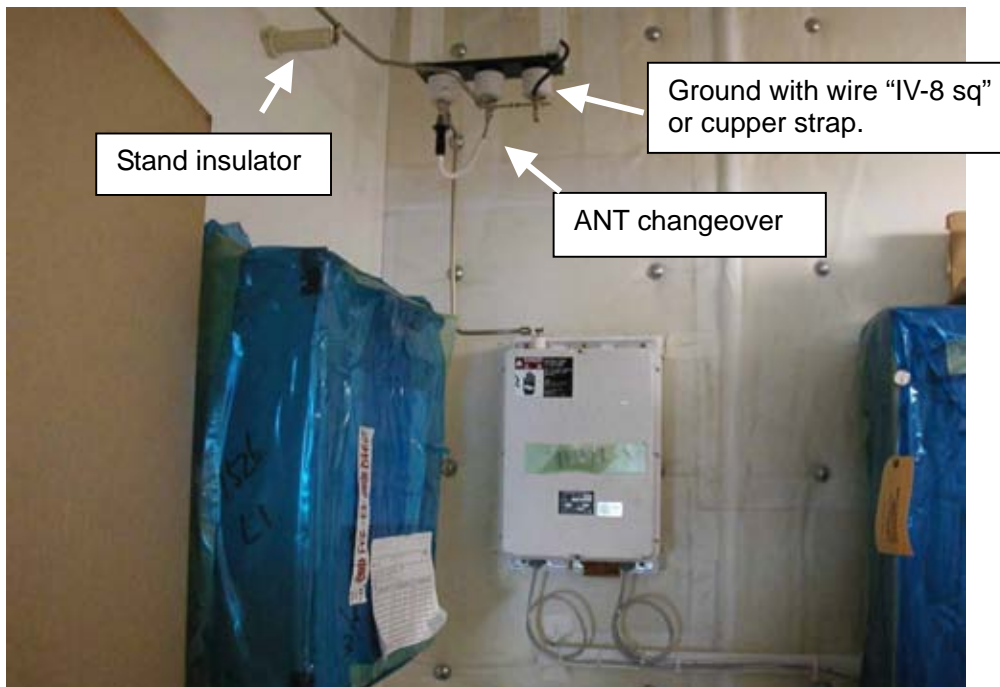

Fig. 3.1.9 Antenna changeover

2. Grounding of antenna coupler

Ground the antenna coupler by the copper strap (width: 50 mm) securely.

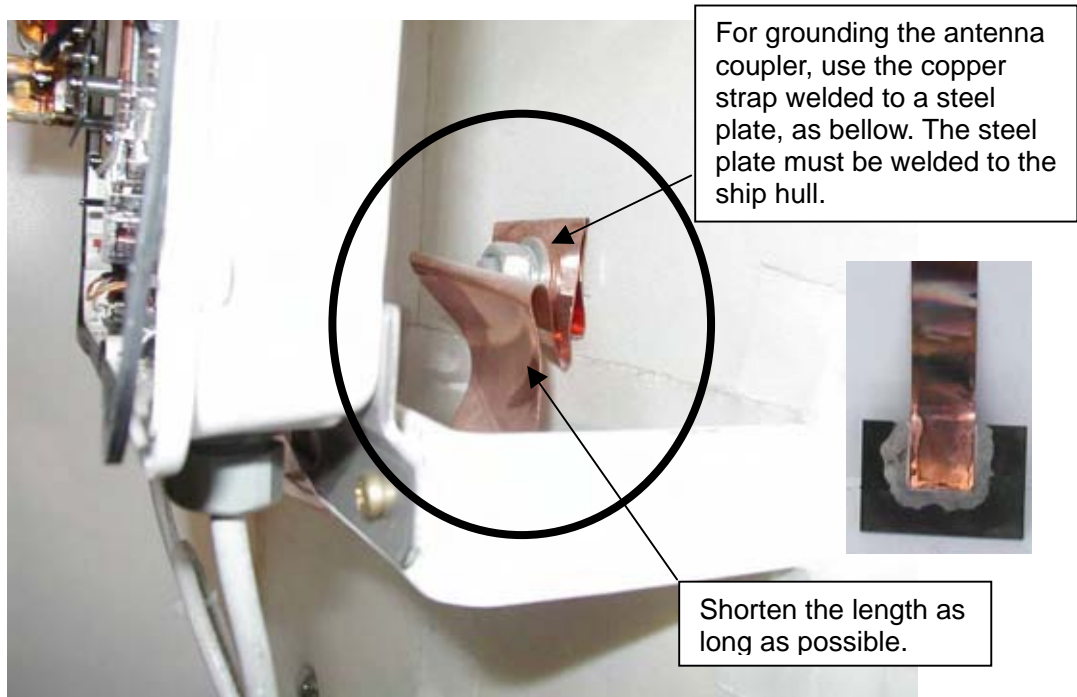

Fig. 3.1.10 Grounding antenna coupler

Use wing nuts to connect the copper strap to the antenna coupler. Fold back the shield of the coaxial cable for clamping.

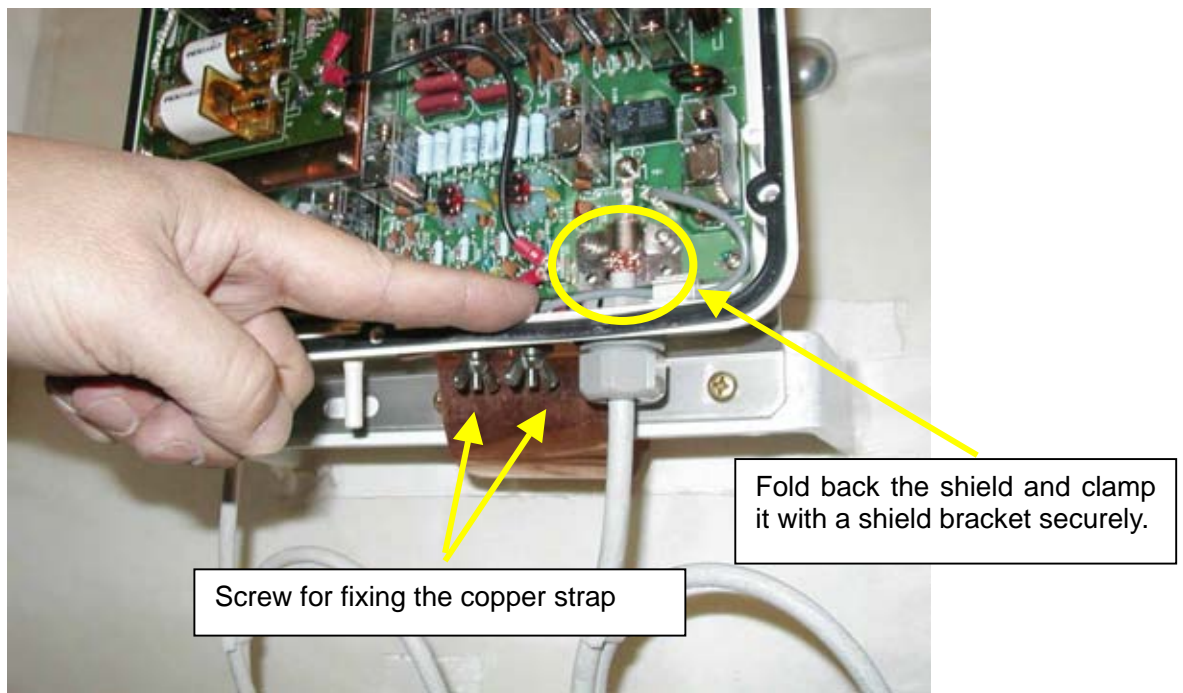

Fig. 3.1.11 Connecting copper strap to antenna coupler

3.2 Installation of MF/HF Antenna No. 2 (Outdoor installation of Antenna coupler)

3.2.1 Mounting of antenna

1. MF/HF Whip antenna

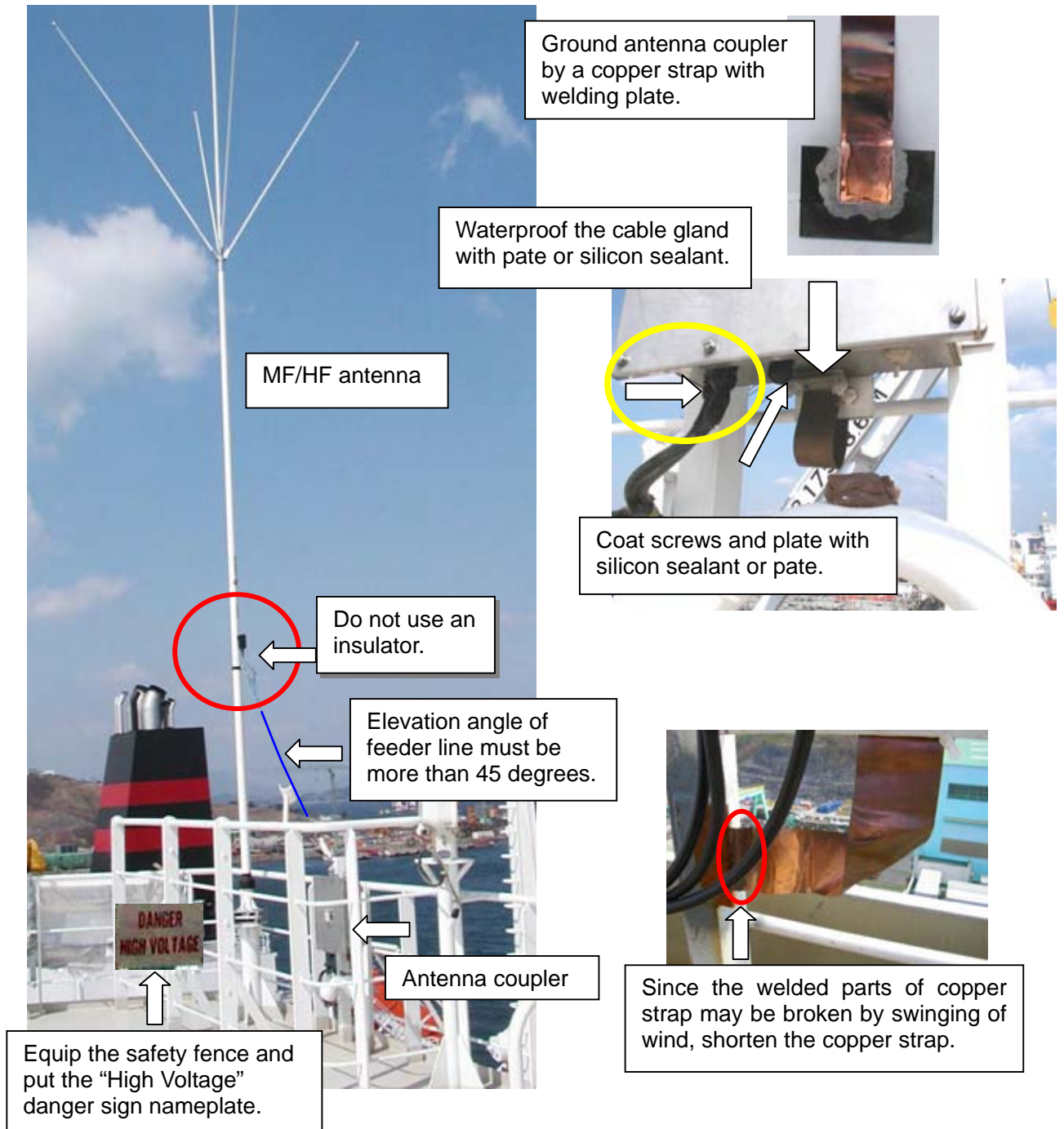

Fig. 3.2.1 Outdoor installation of antenna coupler and whip antenna

2. Improper installation which causes breaking connection parts

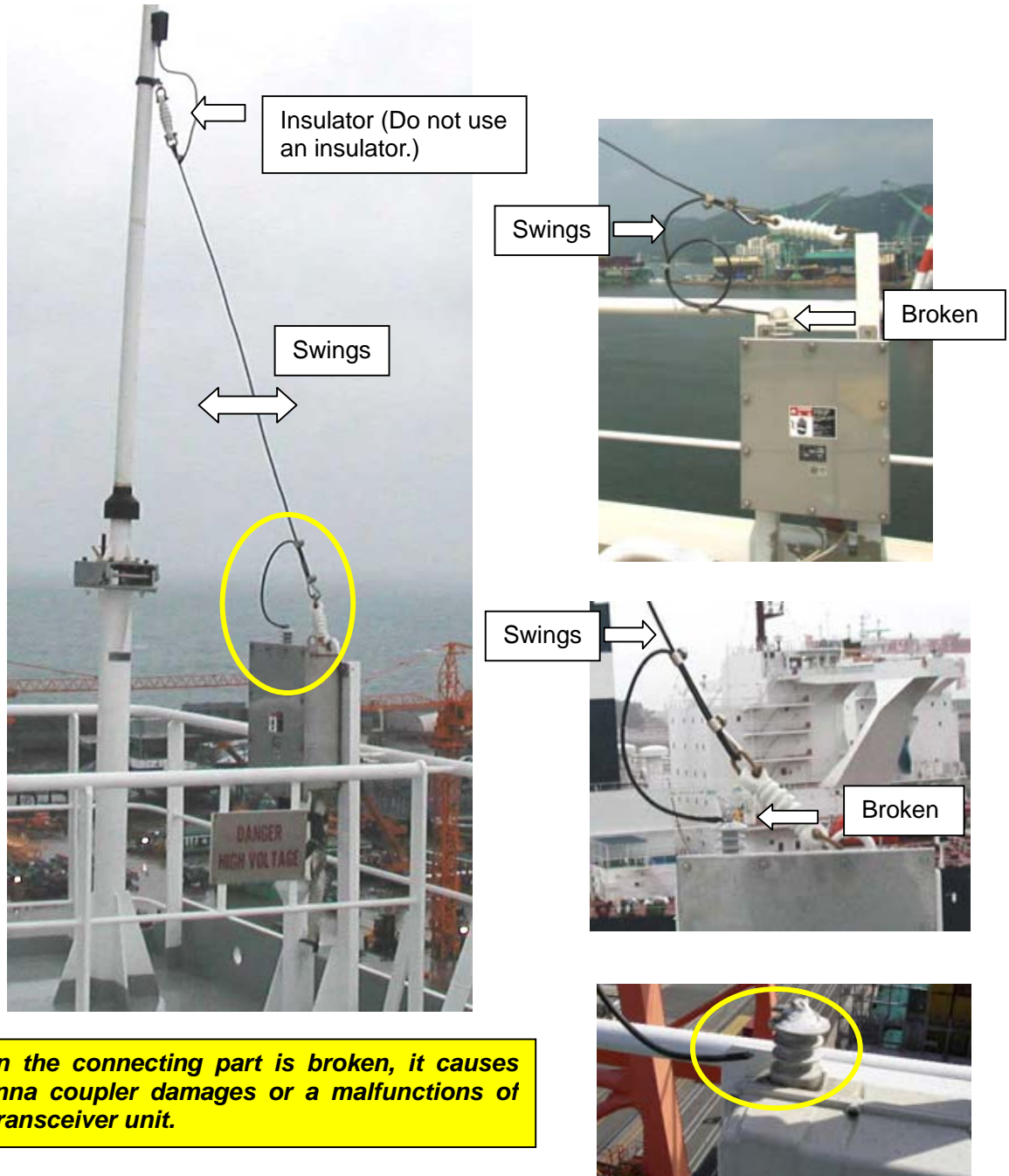

Fig. 3.2.2 Improper installation which cause breaking connection parts

3. How to prevent wire breakage the connection part.



Add antenna wire clip.
(NO. 22/DIA=6.2 MM)

Procedure

1. Put two antenna wire clips (NO. 22/DIA=6.2 MM) through the lead-in wire.
2. Wind a piece of antenna wire around the lead-in insulator one time.
3. Using wire clips, fix the antenna lead-in wire to the wire turned around the insulator in step 2, leaving 500 mm for a loop.
4. Put a 100-mm-long piece of antenna wire through the lead-in insulator.
5. Put the antenna lead-in wire through the lead-in insulator, making a loop about 120 mm diameter.
6. Tighten the screw on the insulator which fixes the antenna lead-in wire.
7. Apply silicone sealant over the screw to prevent it from loosening.
8. Cut off excess antenna lead-in wire extending past the insulator.

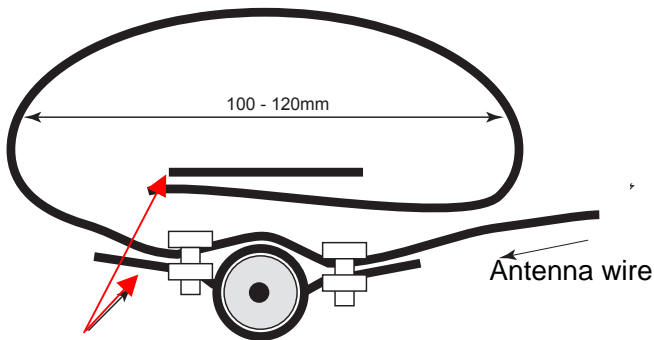

A piece of wire turned around lead-in insulator.

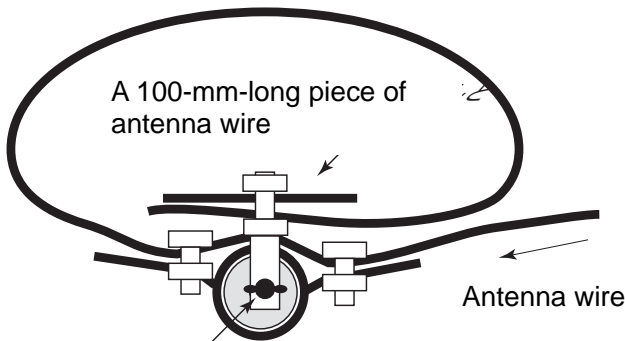

Step 7 Apply silicone sealant.

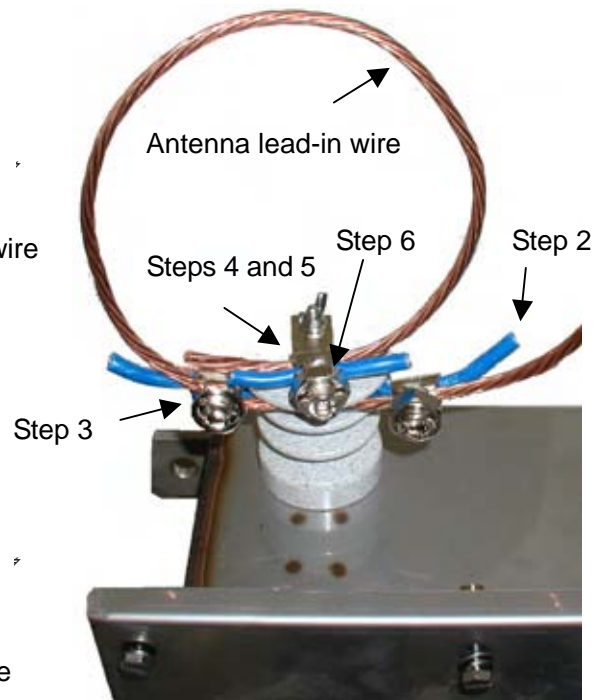

Fig. 3.2.3 Fixing antenna wire to antenna coupler

4. Wiring in antenna coupler “AT-5000”

There are stainless and synthetic resin types of antenna coupler case. Generally, stainless type of case is used for outdoor installation.

Make sure of the 2.5 mm space.

Wiring “high voltage lines” has touched neither other wiring nor parts.

Connect a drain line of a signal cable to the grounding terminal of the coupler board with using crimp on lug.

Check the connection by pulling each wire.

For receiving coaxial cable clamping bracket, the connection is the same as a transmitting coaxial cable.

Cable clamp

Terminal opener

Fix the core wire with screw securely.

Fold back the shield and clamp it with fixture securely.

Connection		
Pin No.		Sig.
1	BRN	Ia+
2	RED	Ia-
3	ORG	TUNE OK
4	YEL	GND
5	GRN	TX
6	BLU	GND
7	WHT	TUNE
8	BLK	DUMMY
9	WHT(Big)	18V+
10	BLK(Big)	18V-

1. Remove the end of each core by 5-6 mm.
2. As shown in the figure, set the opener in a terminal. While pulling the opener downward, insert the core.
3. Release the opener. Tug on the core to confirm it is inserted properly.

Fig. 3.2.4 Wiring of AT-5000

5. Wiring in the antenna coupler “AT-1560”

There are stainless and synthetic resin types of antenna coupler case. Generally, stainless type of case is used for outdoor installation.

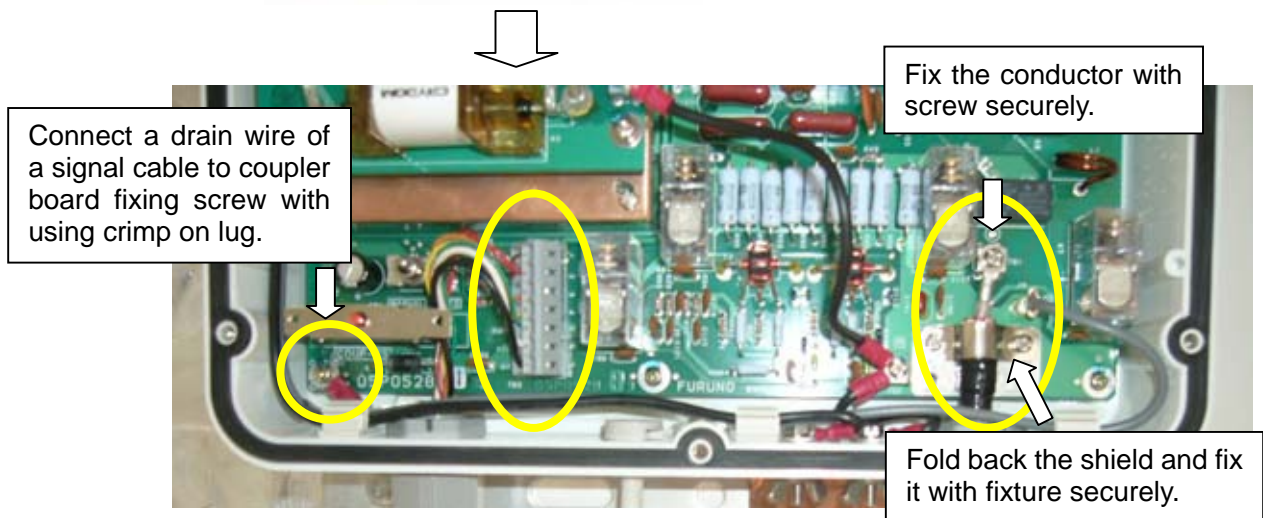
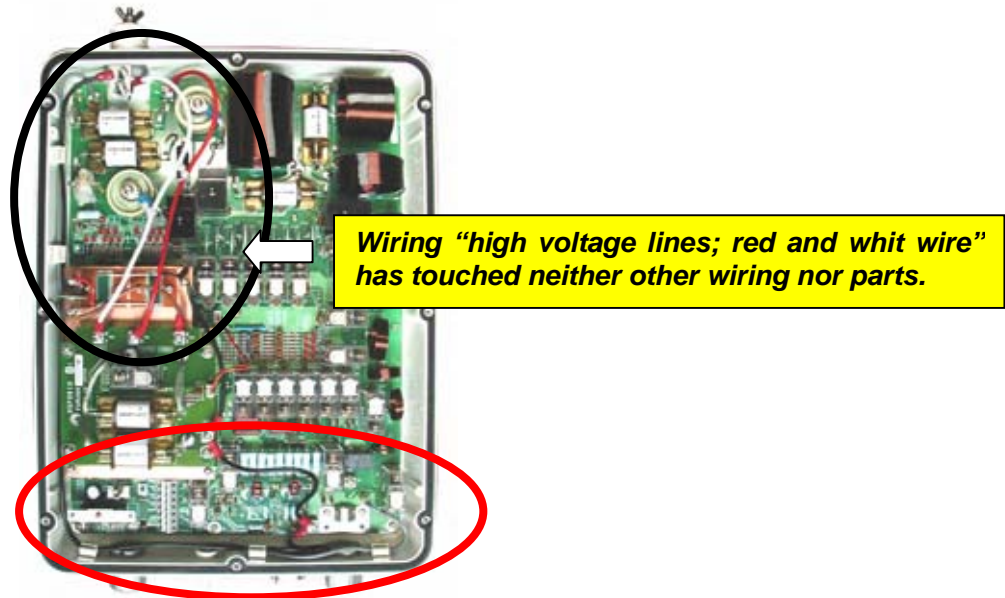

Connection

Pin No.	SIG	
1	BRN	Ia
2	RED	TUNE OK
3	ORG	TUROUGH
4	YEL	TUNE
5	GRN	DUMMY
6	WHT(BIG)	15V+
7	BLK(BIG)	0V

1. Remove the end of each core by 5-6 mm.
2. As shown in the figure, set the opener in a terminal. While pulling the opener downward, insert the core.
3. Release the opener. Tug on the core to confirm it is inserted properly.

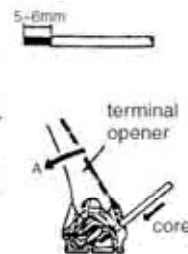

Fig. 3.2.5 Wiring of AT-1560

3.3 Installation of Radio Console

3.3.1 General Mounting of Radio console

Cover the console with a vinyl sheet to keep dust away and prevent damaging, when not working.



Fig. 3.3.1 Protect from damagingies

GMDSS Operating
Guidance for Ship
Master in Distress Situations

COMSAR/Circ.25
(Actions by upon reception of HF,
VHF/MF DSC Distress Alert)

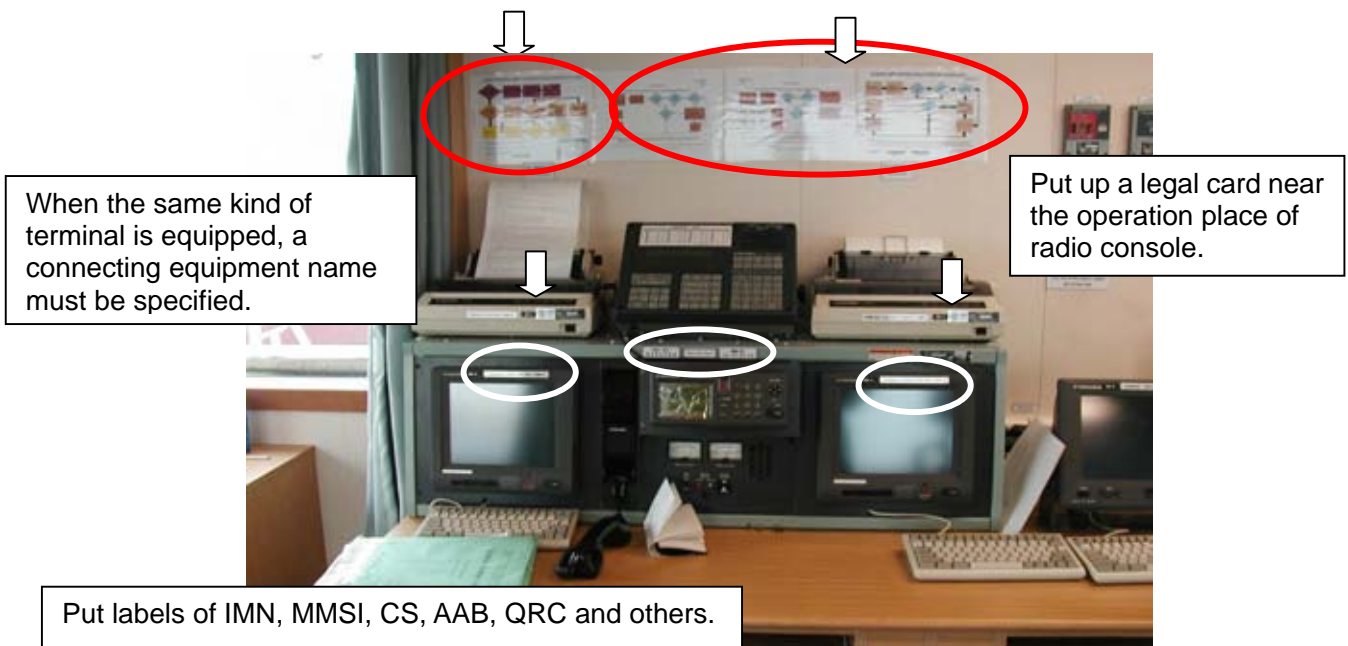

Fig. 3.3.2 Indication of legal card and others

1. High of radio console

When it is the "Fig. 3.3.3 Installation of radio console-1" which a front field of view opens, the height of a console depend on shipping classifications. If it is a DNV shipping classification, less than 1.2 m is demanded from the floor. However, if a console is equipment like "Fig. 3.3.4 Installation of radio console-2", it is not related to them.

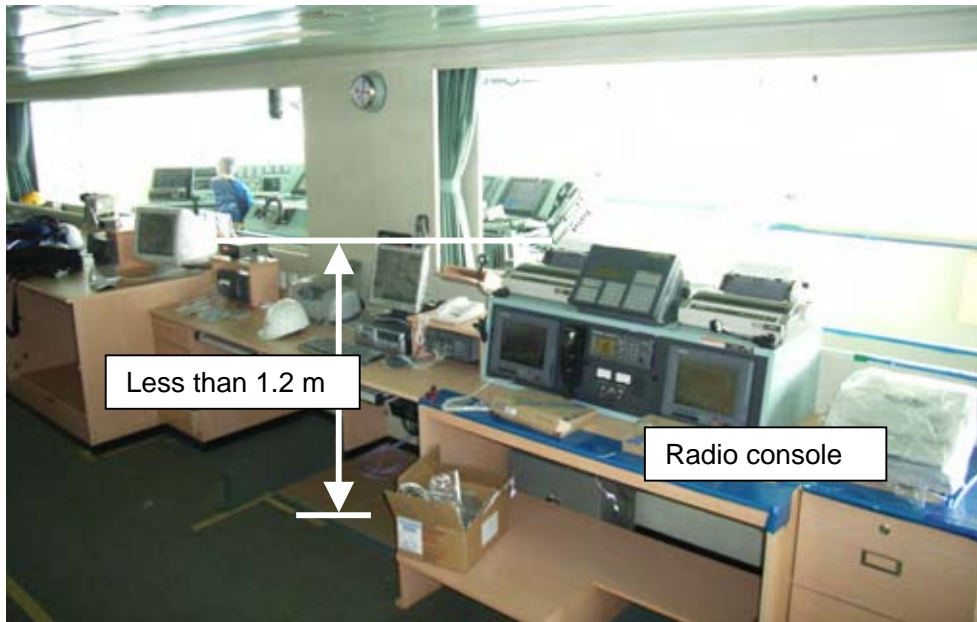

Fig. 3.3.3 Installation of radio console-1

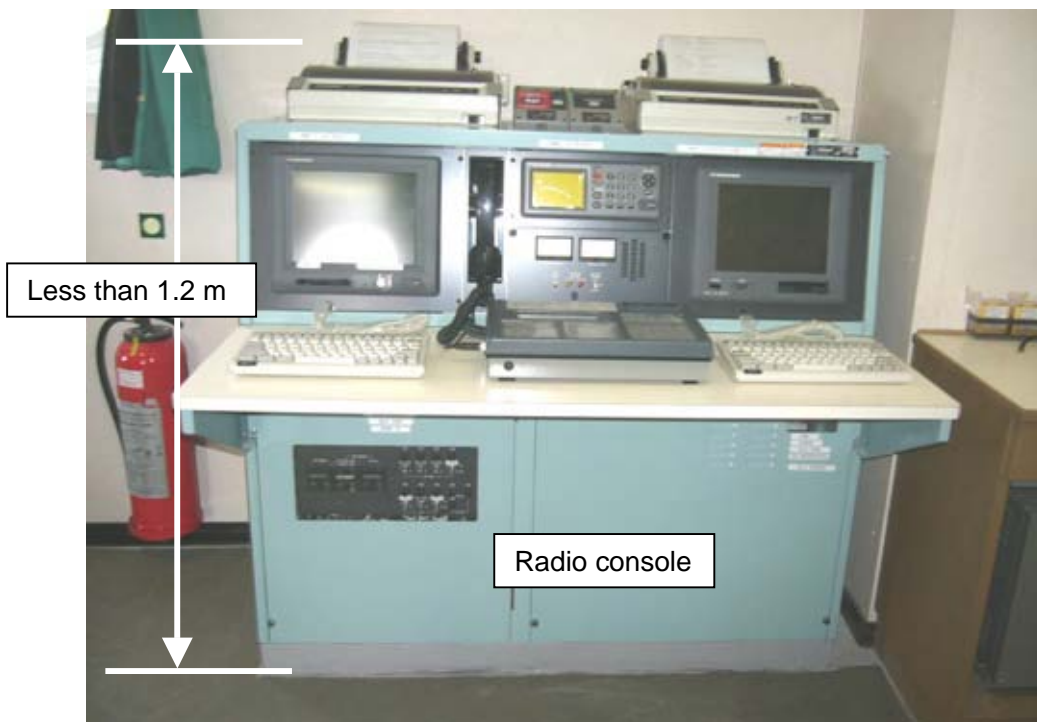

Fig. 3.3.4 Installation of radio console-2

3.3.2 Mounting of RC-1800F console (150/250W: FS-1570/2570)

1. Grounding and cabling

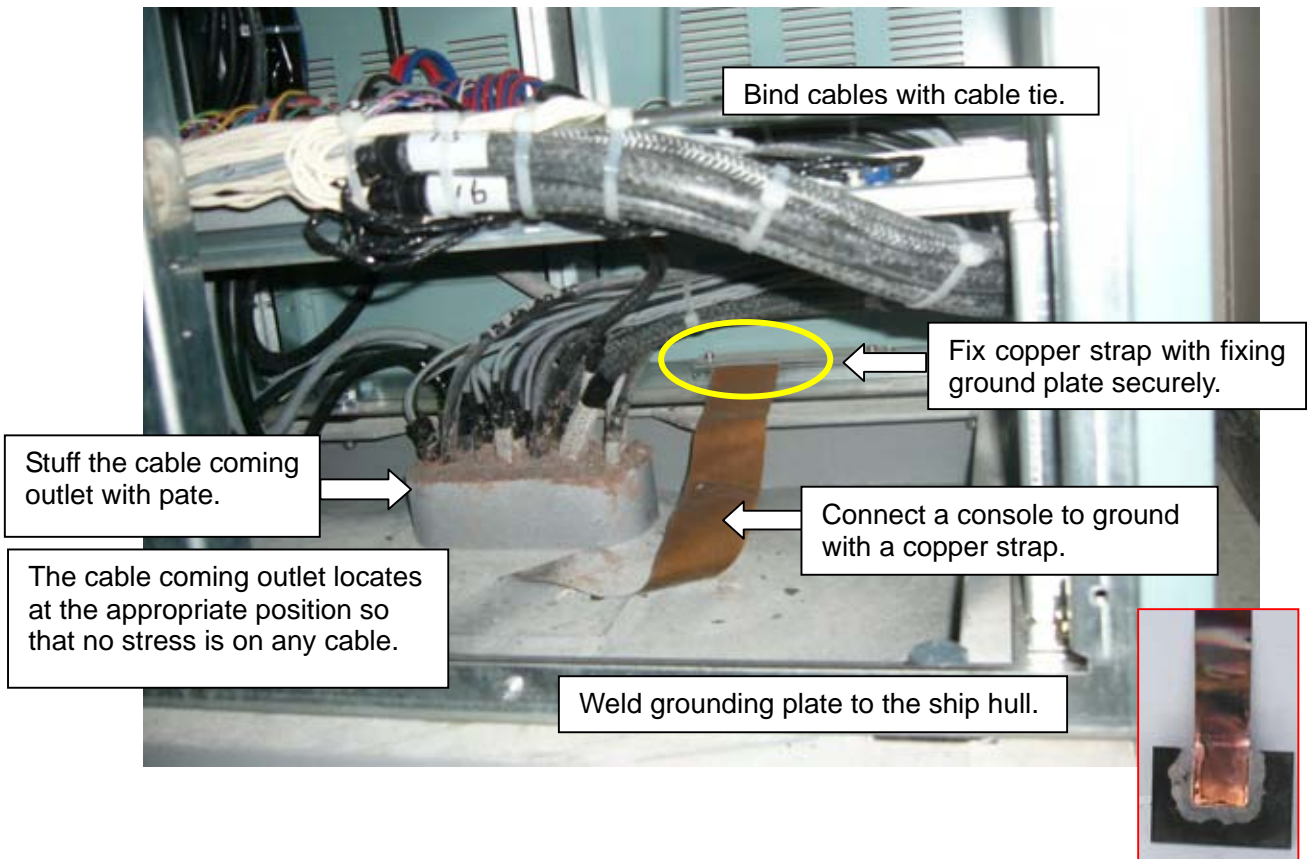
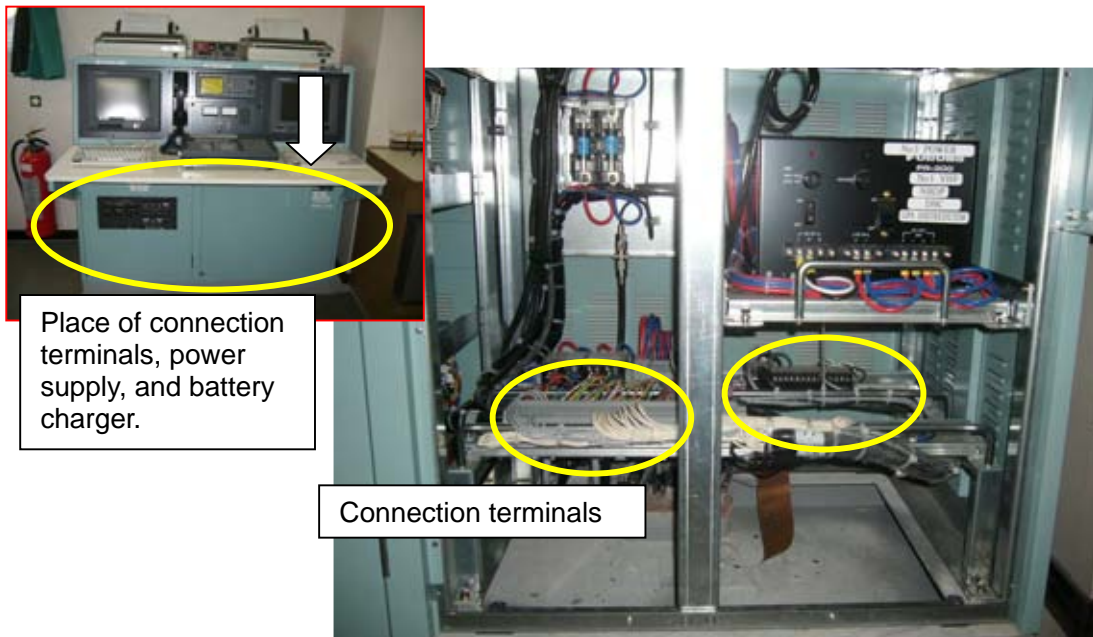

Fig. 3.3.5 Cable coming outlet of console

2. Wiring in the middle and lower parts of console

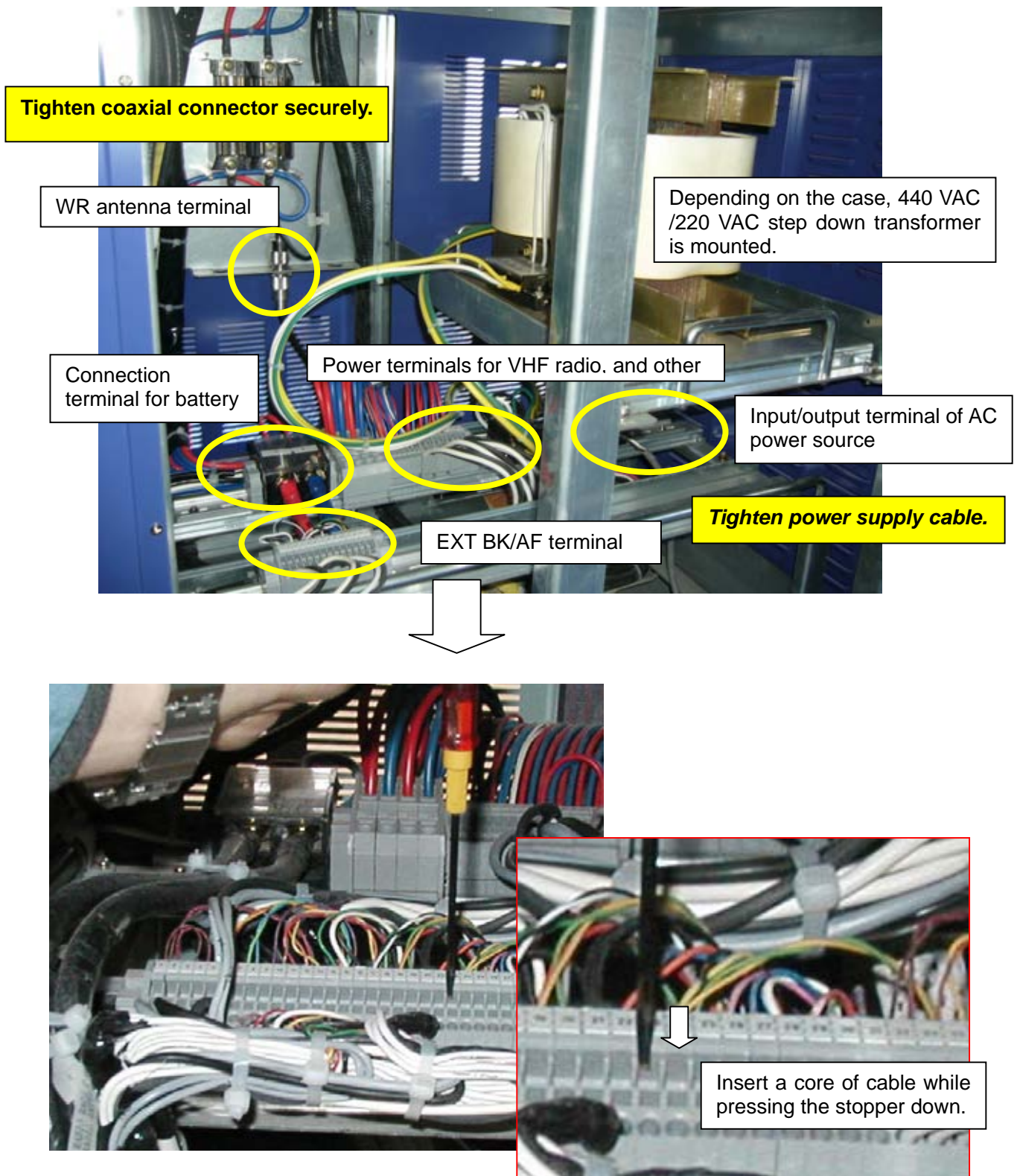

Fig. 3.3.6 Wiring in the middle and lower parts of console

3. Improper fabrication of M-type coaxial connector

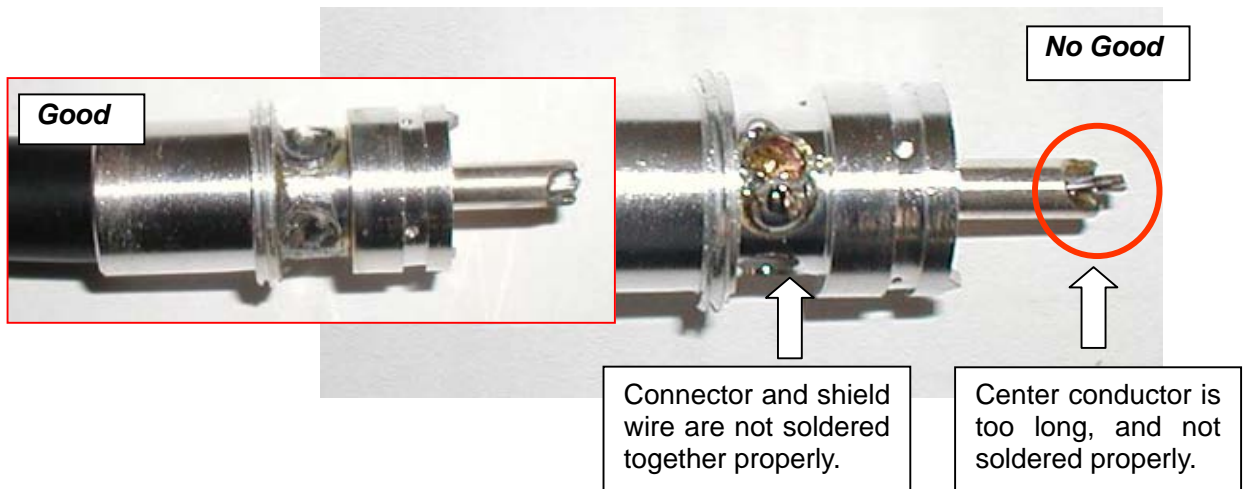

Fig. 3.3.7 Improper fabrication of M-type coaxial connector

4. Wiring of the upper left side in console (not required in the field)

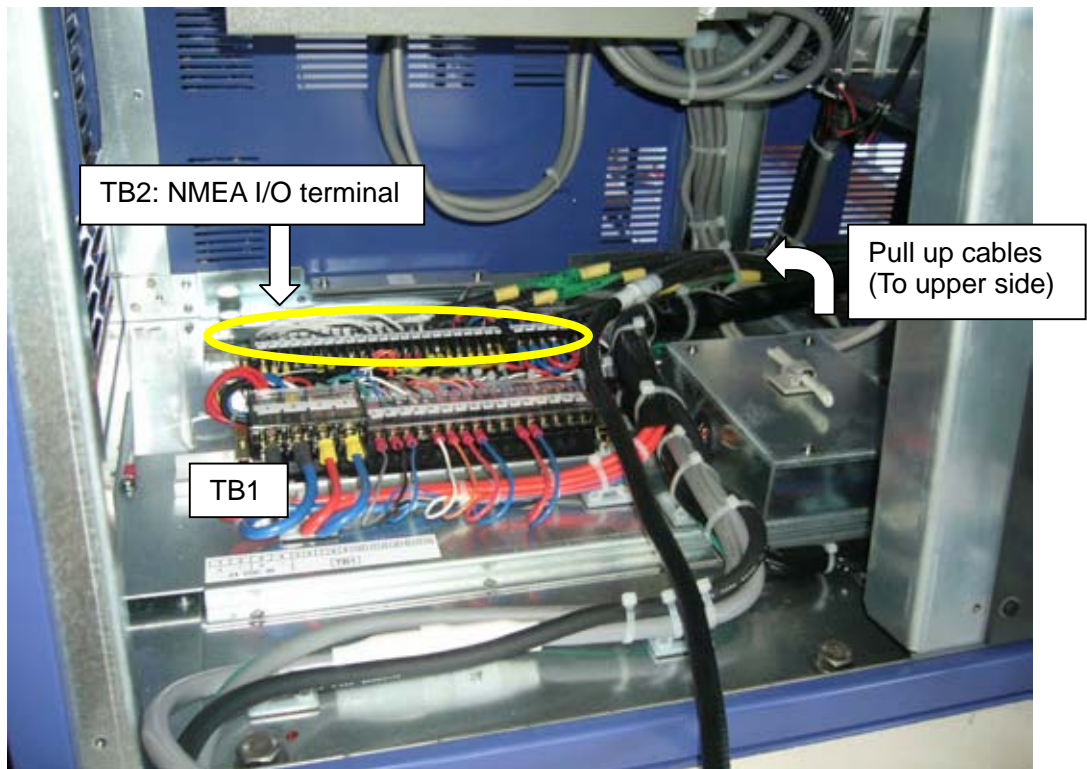

Fig. 3.3.8 Upper left side in console

5. MF/HF transceiver unit in console: wiring of FS-1570T/2570T

For cabling of MF/HF transceiver unit, remove the upper board on the right-hand side of a console.

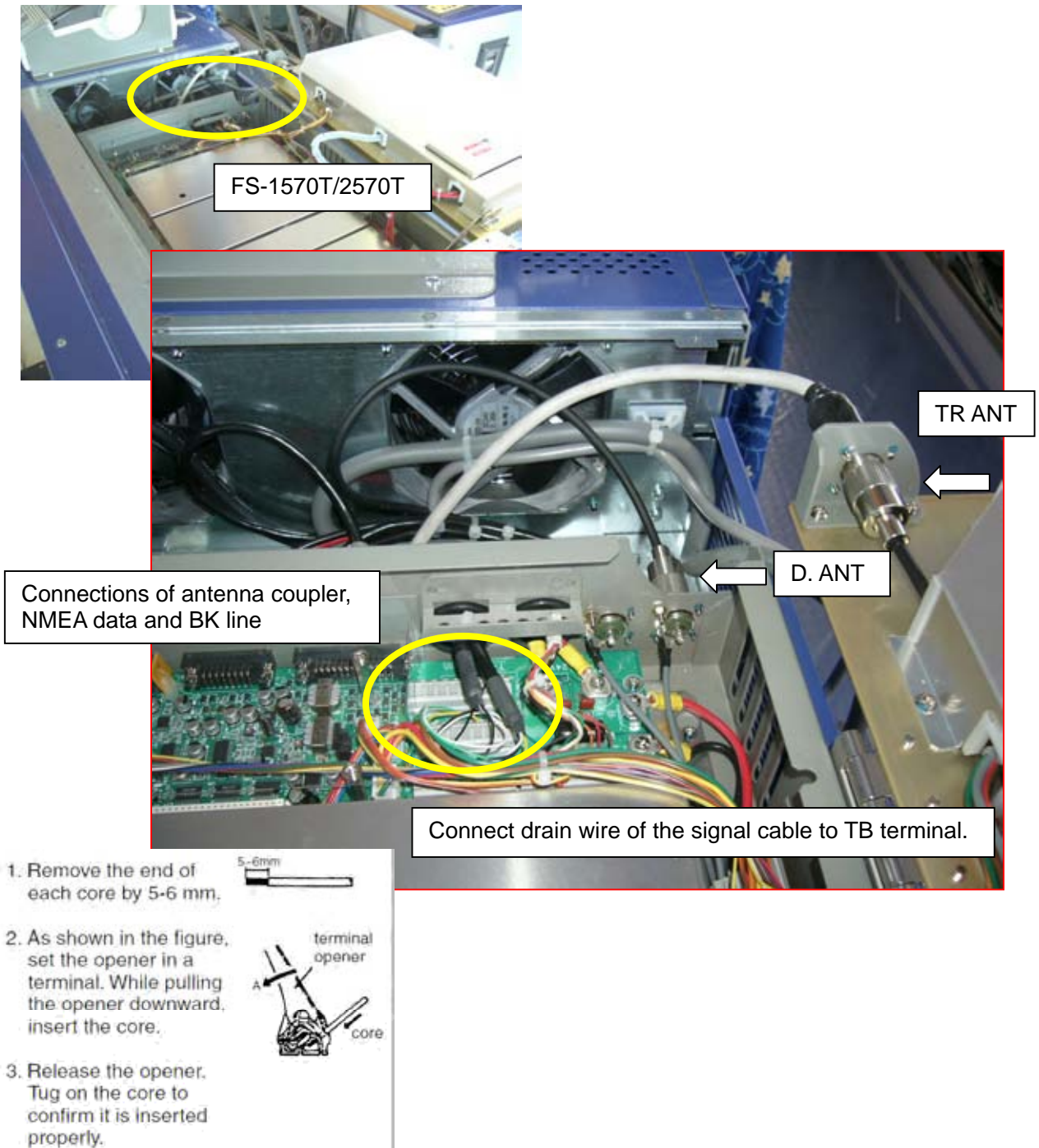

Fig. 3.3.9 Wiring of FS-2570/1570T

6. Connection of Inmarsat C

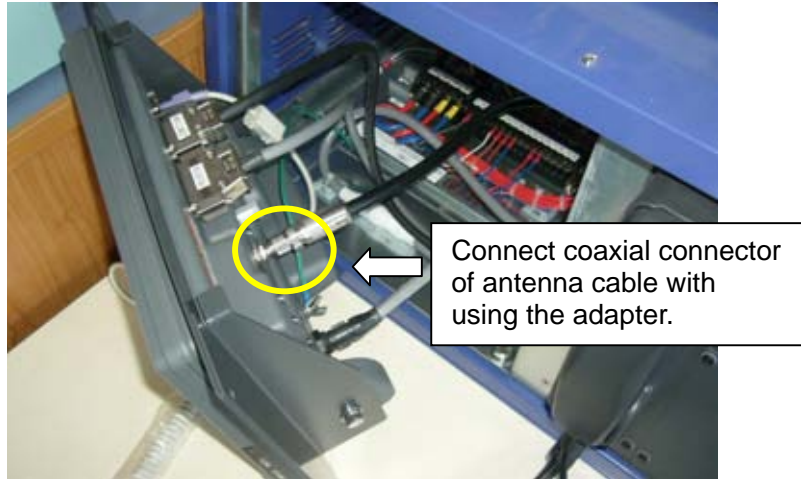
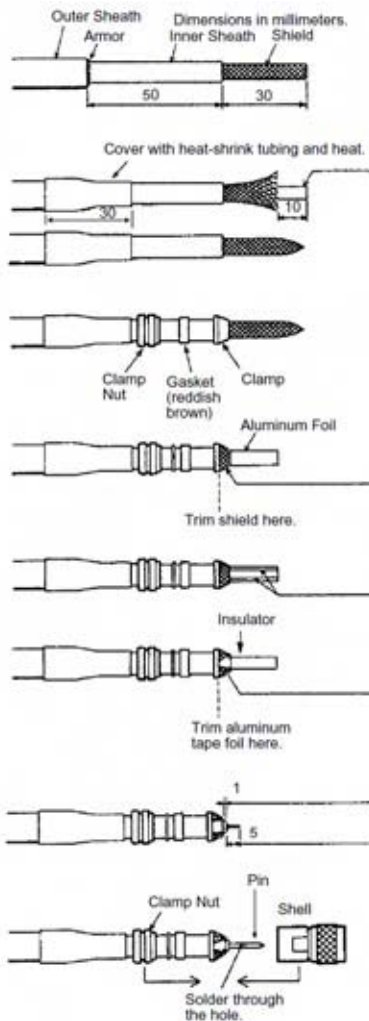

Fig. 3.3.10 Connection of Inmarsat C

Fabrication of N-P-8DFB connector



Remove outer sheath and armor by the dimensions shown left. Expose inner sheath and shield by the dimensions shown left.

Cut off insulator and core by 10 mm.

Twist shield end.

Slip on clamp nut, gasket and clamp as shown in left.

Fold back shield over clamp and trim.

Cut aluminum foil at four places, 90 from one another.

Fold back aluminum tape foil onto shield and trim.

Expose the insulator by 1 mm. Expose the insulator by 5 mm.

Slip the pin onto the conductor. Solder them together through the hole on the pin.

Insert the pin into the shell. Screw the clamp nut into the shell.

Tighten by turning the clamp nut. Do not tighten by turning the shell.

7. Junction Box (IC315),

Distress Alert/Received Call unit (IC305) and Alarm unit (IC306)

The Distress Alert/Received Call unit and Alarm unit are connected through junction box "IC-315" to console when installing without the inside of a console. When installing them in the console, they are fixed in the factory.

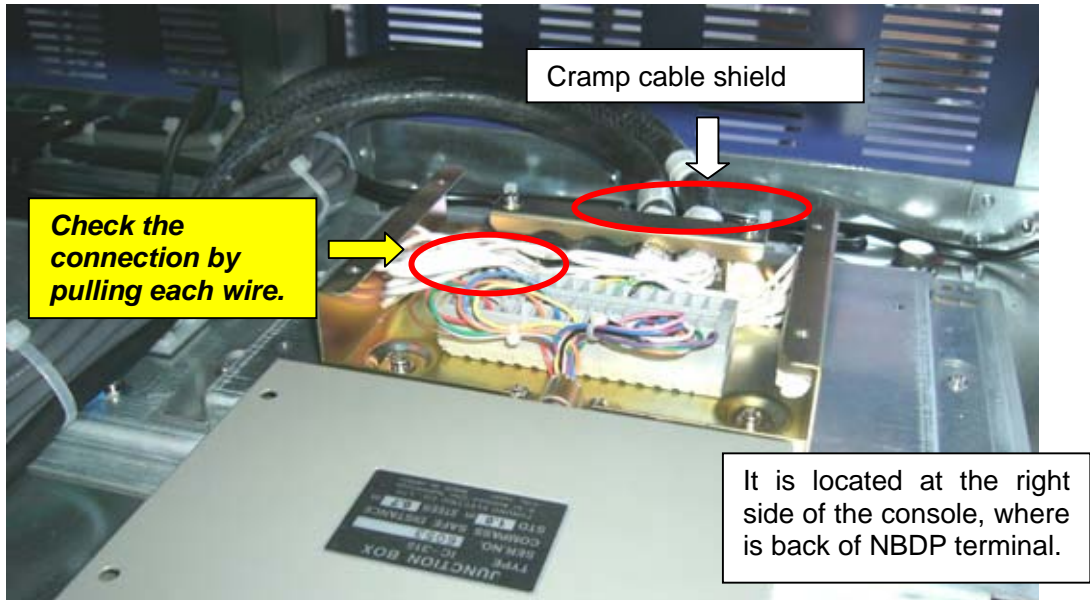

Fig. 3.3.11 Wiring of Inmarsat C junction box

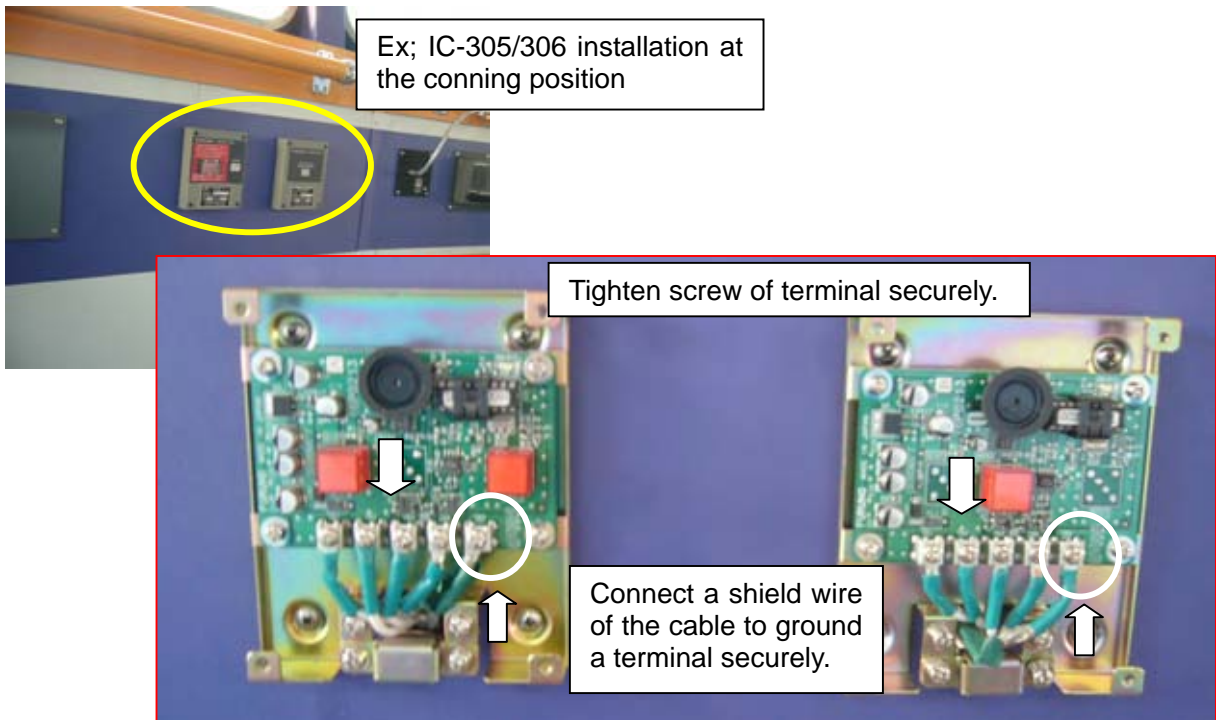

Fig. 3.3.12 Wiring in the Distress Alert/Received Call unit and Alarm unit

8. Reassembling the units

Tighten the connector, ground terminal and screws, which has dismantled for installation.

Left side of console
Inmarsat C terminal



Right side of console
NBDP terminal



Center of console
MF/HF radio controller



Fig. 3.3.13 Reassembling the terminal units

3.3.3 Mounting of RC-1800F console (400W: FS-5000)

1. Installation of FS-5000 transceiver unit

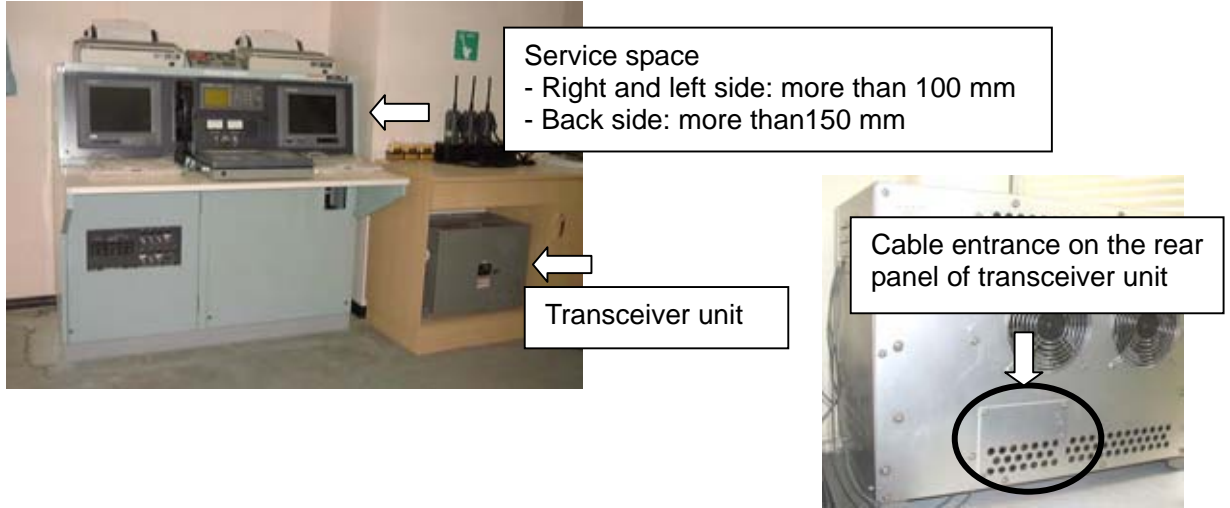

Fig. 3.3.14 Installation of FS-5000 transceiver unit

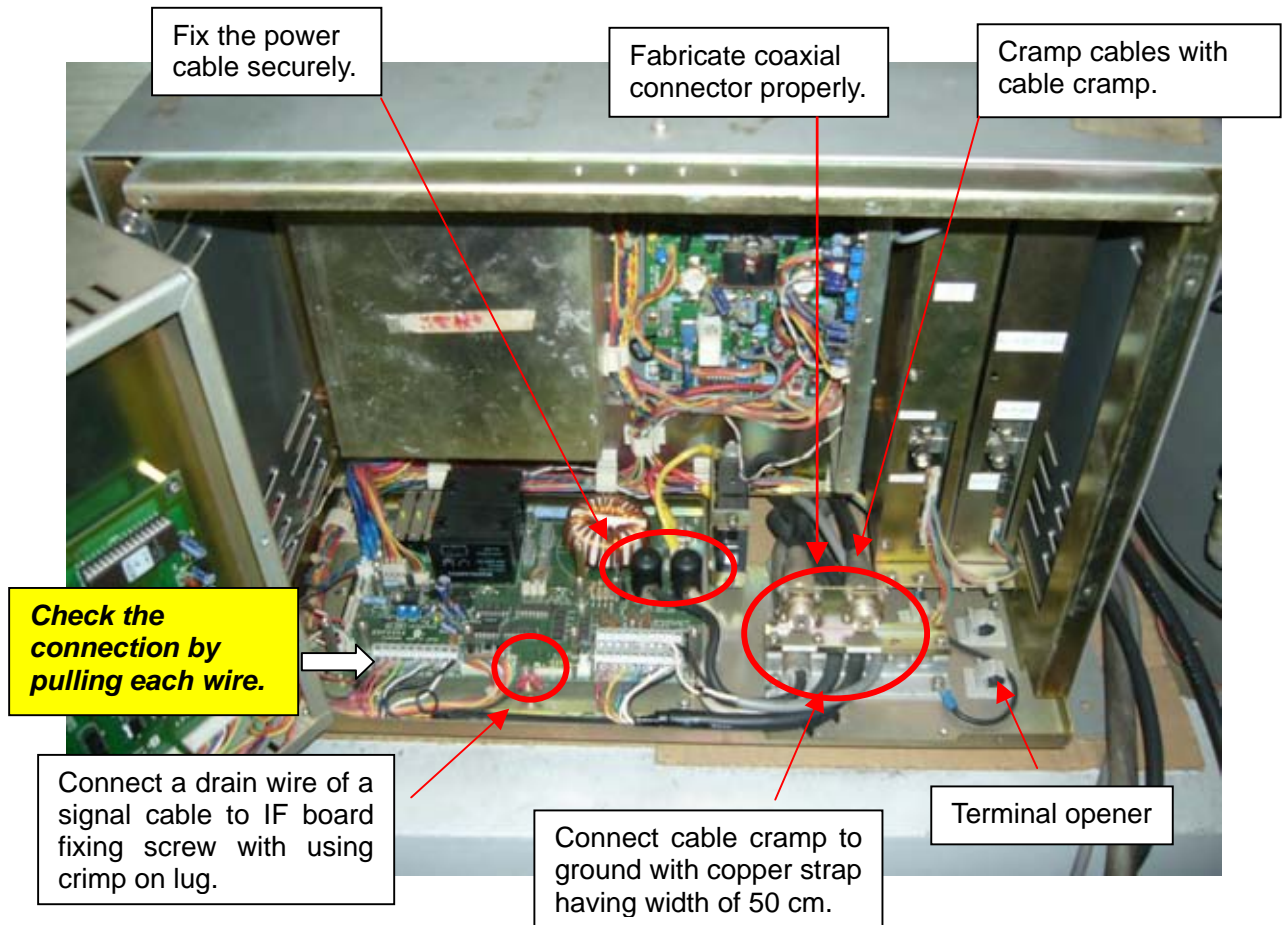
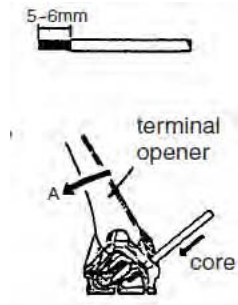

Fig. 3.3.15 Installation of FS-5000 transceiver unit

How to Use Terminal Opener at terminal

1. Remove the end of each core by 5-6 mm.
2. As shown in the figure, set the opener in a terminal. While pulling the opener downward, insert the core.
3. Release the opener. Check the connection by pulling each wire.



2. Improper fabrication of M-type coaxial connector

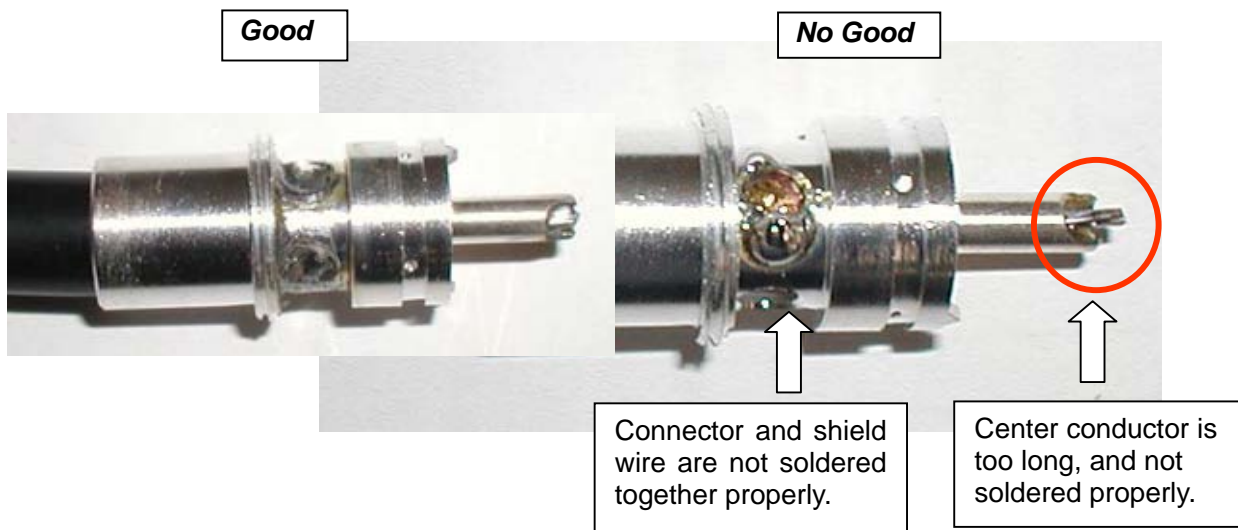

Connector and shield wire are not soldered together properly.

Center conductor is too long, and not soldered properly.

Fig. 3.3.16 Fabrication of M-type coaxial connector

3. Installation of FS-5000 Controller unit

When installing control unit on the table, there is an optional Trunion mount and fixing base fixing base.

Type: OP05-37 (005-931-760)

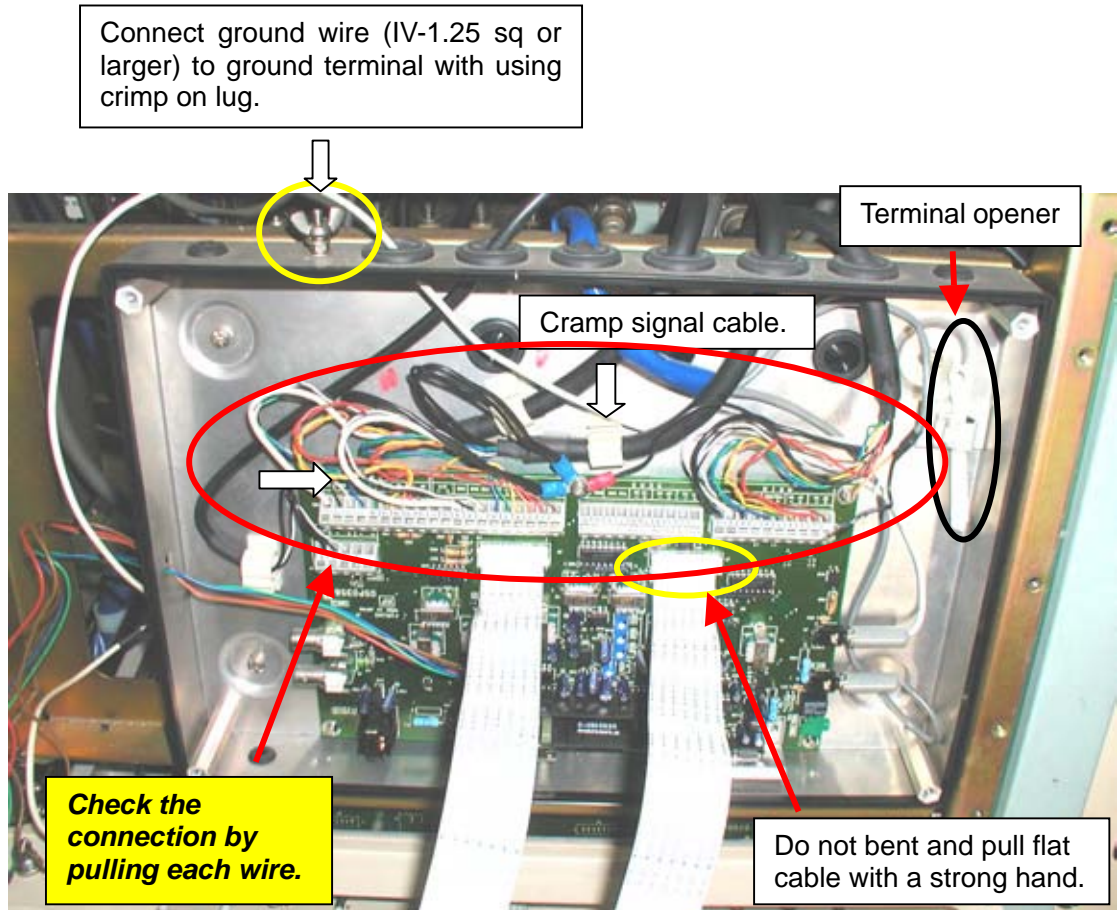

Connect the drain wire of signal cable between transceiver and controller unit to the chassis of controller with screw which fixing the PC board.

Connect the drain wire of the cable between the controller and DSC terminal, or NBDP terminal to the S-GND of TB terminal.

Fig. 3.3.17 Installation of controller:

How to Use Terminal Opener at terminal

1. Remove the end of each core by 5-6 mm.
2. As shown in the figure, set the opener in a terminal. While pulling the opener downward, insert the core.
3. Release the opener. Check the connection by pulling each wire.

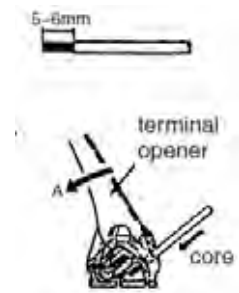

3.4 Installation of RX antenna

3.4.1 Mounting of Antenna junction box

- * All connection must be tighten.
- * Apply silicone sealant to bolts, nuts, grounding points and terminals.

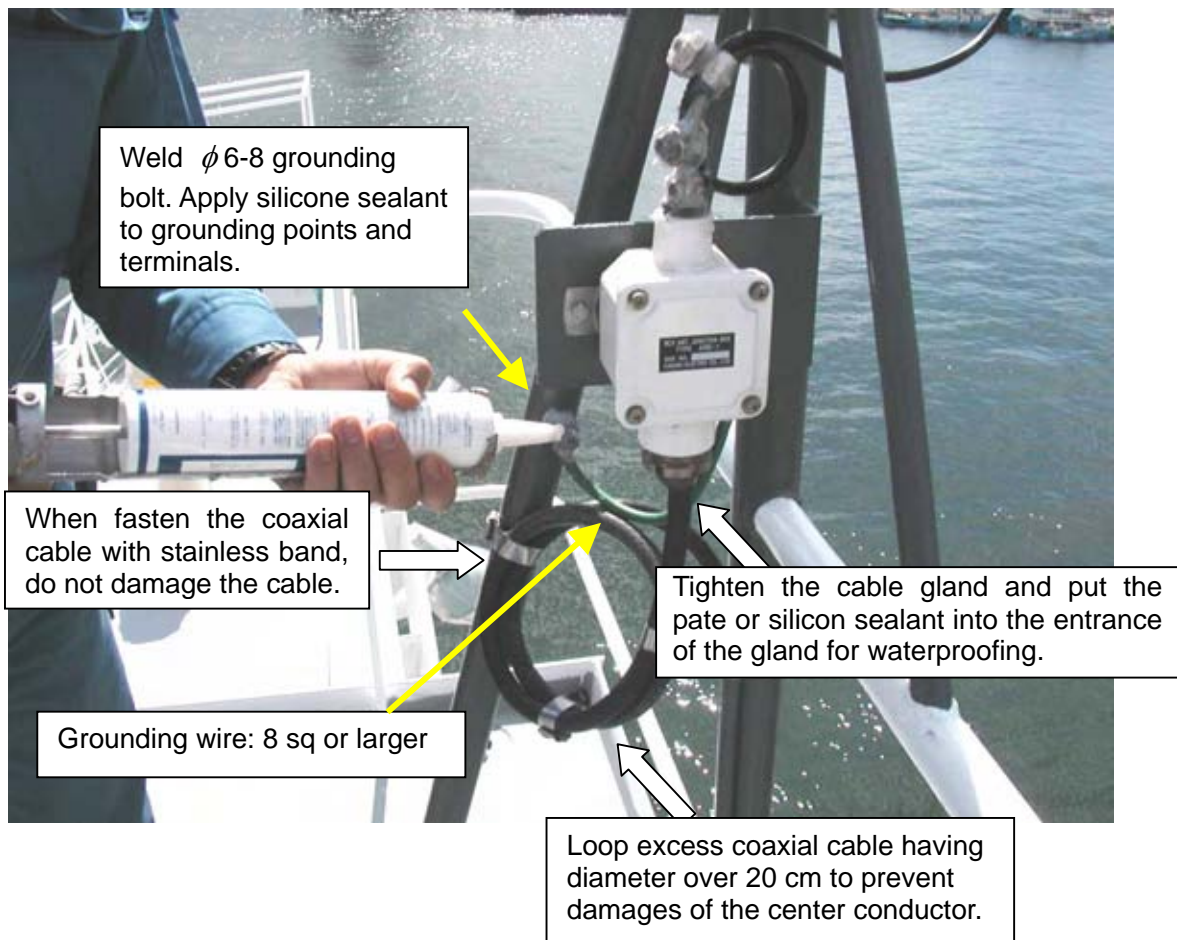

Fig. 3.4.1 Mounting of Antenna junction box

3.4.2 Installation of Antenna with Pre-amplifier

- * Fix the coupler onto the antenna pole by using hose clamps and a bracket.
- * Waterproof the junction part of coaxial cable with self bounding tape and vinyl tape properly.
- * When loops coaxial cable, keep diameter over 20 cm in order to prevent damages of the center conductor.

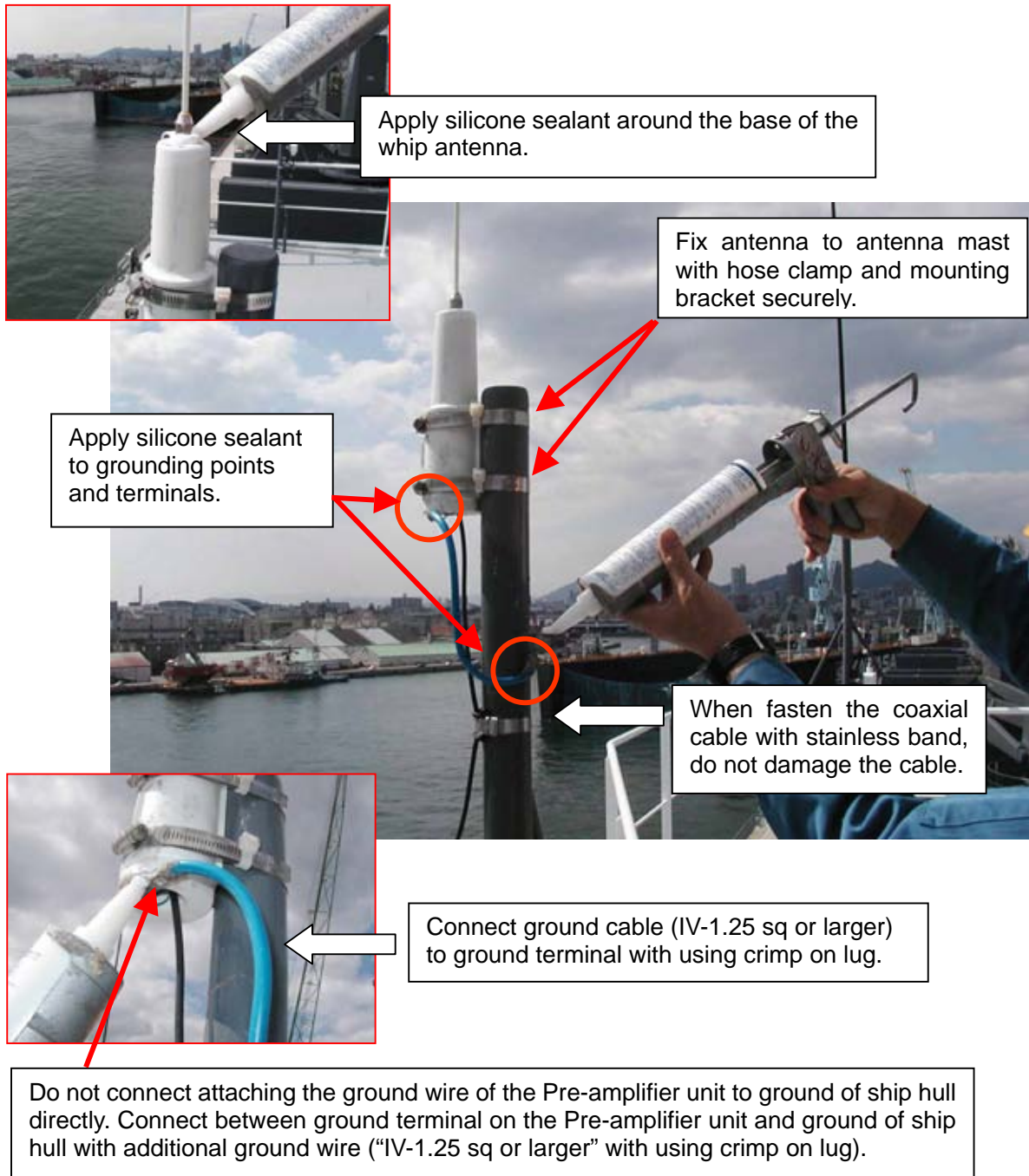

Fig. 3.4.2 Installation antenna with Pre-amplifier-1



Loop excess coaxial cable having diameter over 20 cm to prevent damages the center conductor.

Waterproofing the connectors

How to wrap

Pull the self-bonding tape to be about two times in length and wind it up, overlapping by 1/2 the width of the tape. And then wrap vinyl tape on it as well. Tighten both ends with cable ties.

Fig. 3.4.3 Installation antenna with Pre-amplifier-2

3.5 Installation of Reserve source (Battery)

3.5.1 Lead-acid battery

Battery cables must have sufficient dimensions to prevent voltage reduction. Connections must be tightened in order to reduce voltage drop caused by the contact resistance. Apply grease to battery terminals to prevent corrosion.

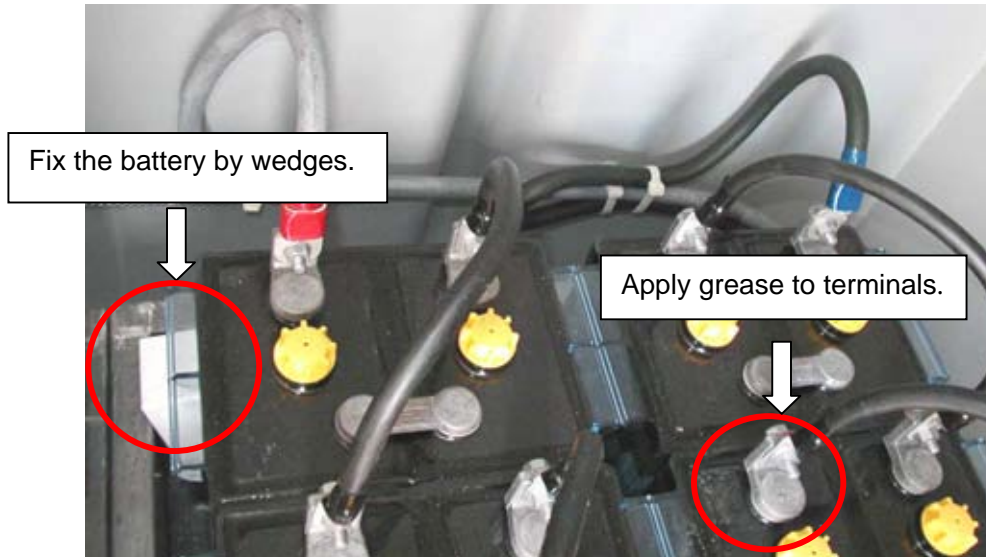

Fig. 3.5.1 Installation of Lead-acid battery

- Board up the inside of the box with copper plates for corrosion-proof.
- Spare parts must include the distilled water, specific gravity meter and voltmeter.

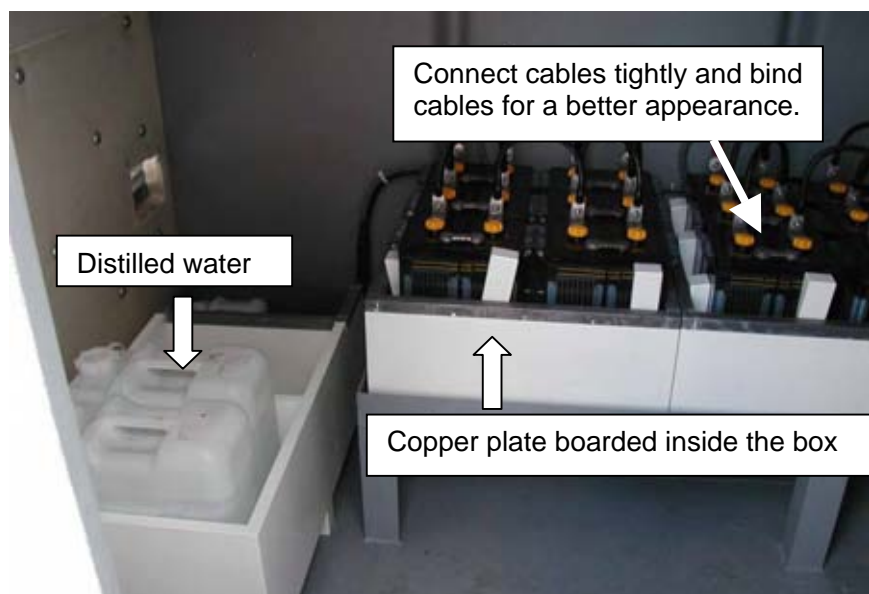

Fig. 3.5.2 Installation of Lead-acid battery

Maintenance parts of Lead-acid Battery



Fig. 3.5.3 Maintenance parts of Lead-acid Battery

3.5.2 Maintenance Free battery

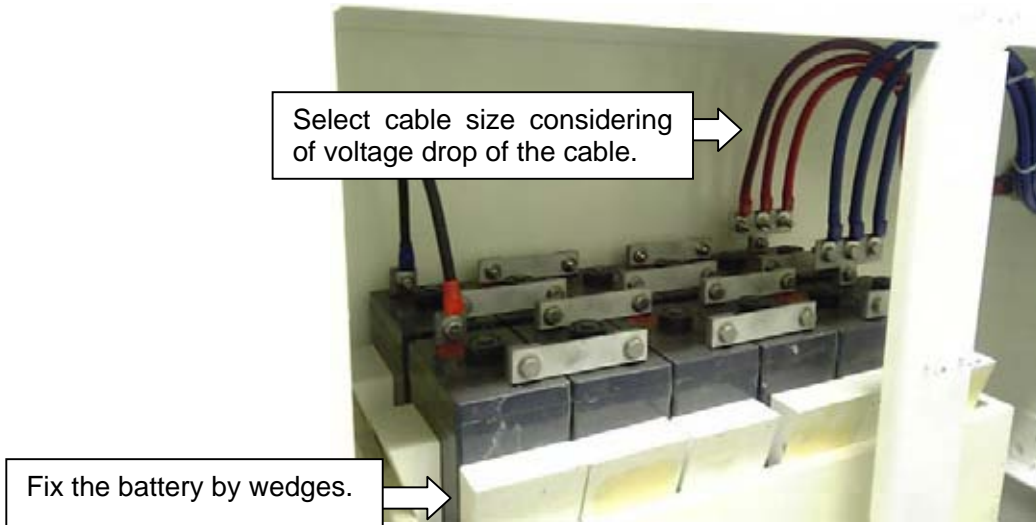

Fig. 3.5.4 Installation of maintenance free battery

When using a maintenance free battery, put labels of “AUTO/OFF” and “CAUTION”, as bellow.

Charger control SW

Lead-acid battery

Maintenance free battery

No use AUTO

AUTO/OFF

CAUTION

Fig. 3.5.5 Labels of “AUTO/OFF” and “CAUTION”

4.1 Installation of VHF Antenna

- * Fix the antenna with antenna fixing bracket securely.
- * Waterproof the junction part of coaxial cable with self-bonding tape and vinyl tape properly.
- * Loop excess coaxial cable having diameter over 20 cm to prevent damaging the center conductor.

When the antenna is installed as shown in figure 4.1.1 (a), the reflection power increases. Therefore, install the antenna as shown in figure 4.1.1 (b).

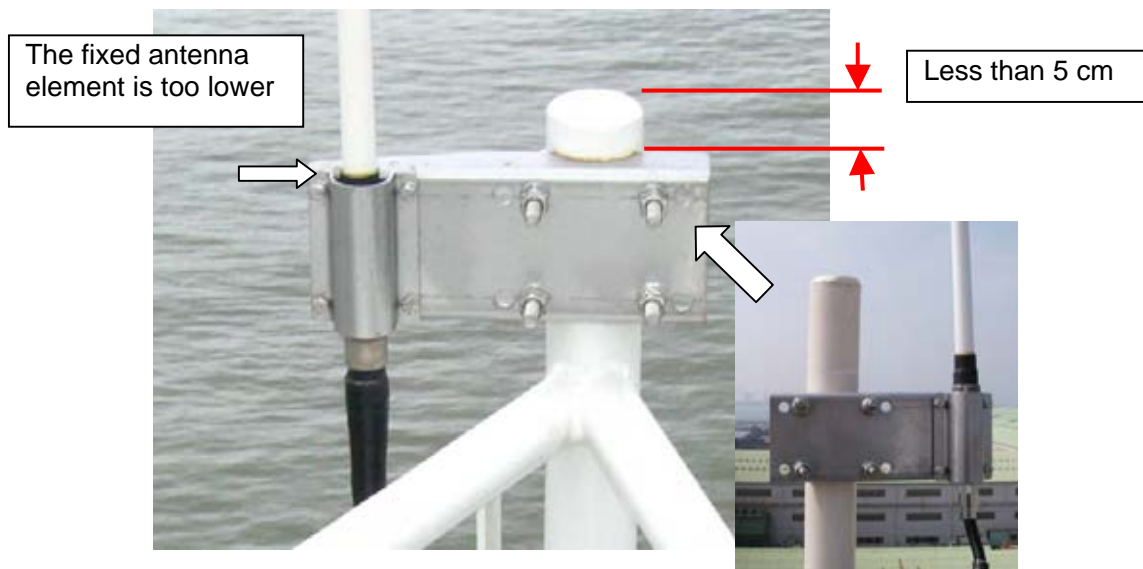

Figure 4.1.1(a) Improper installation

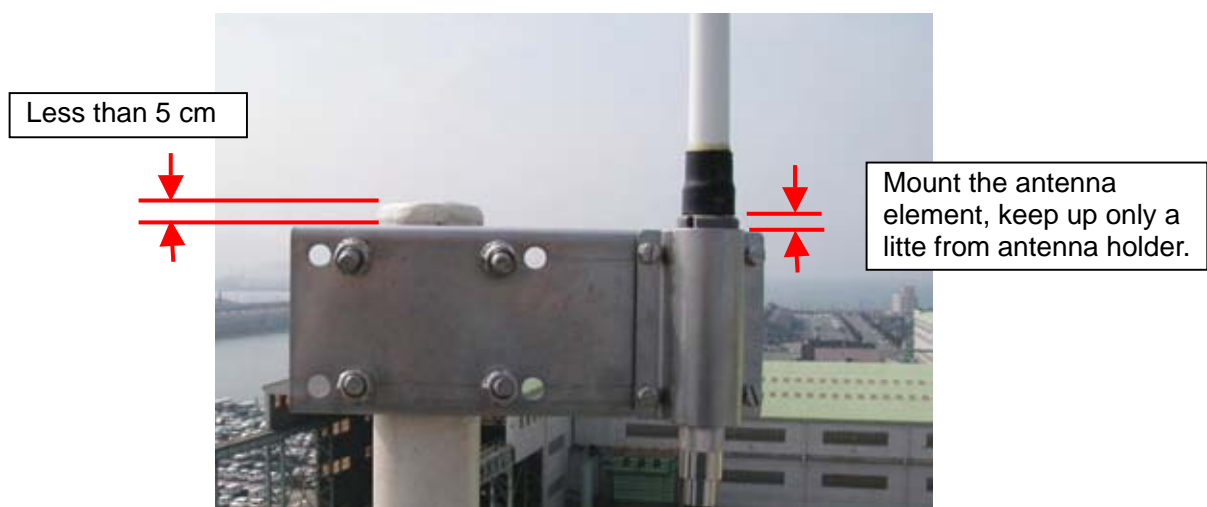

Fig. 4.1.1(b) Proper installation

Waterproofing with tape.

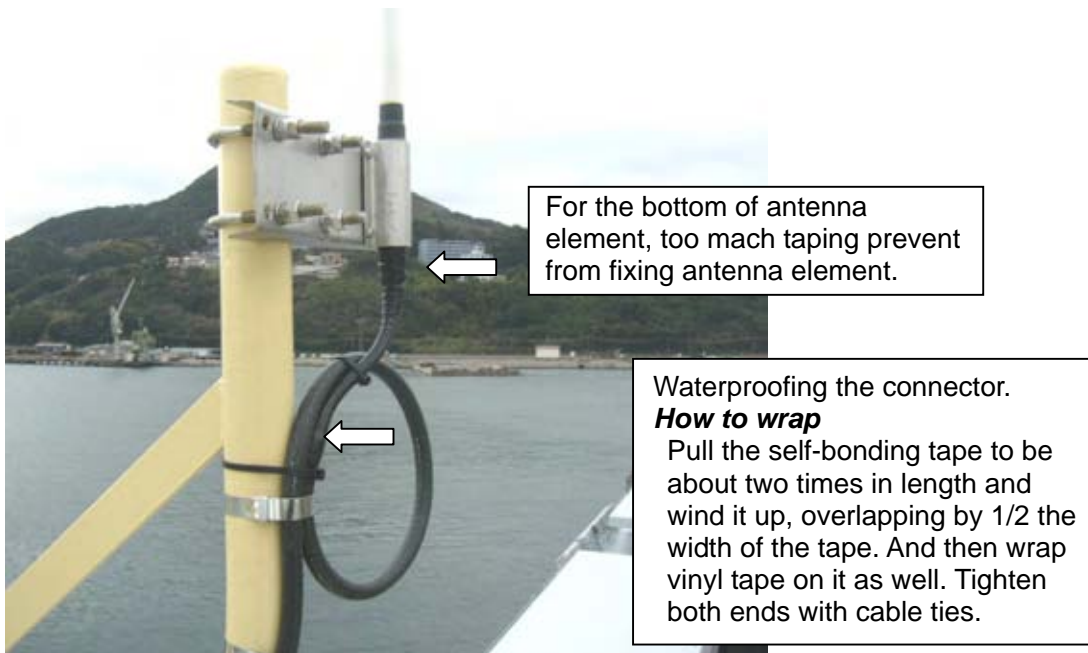

Fig. 4.1.2 waterproofing with tape

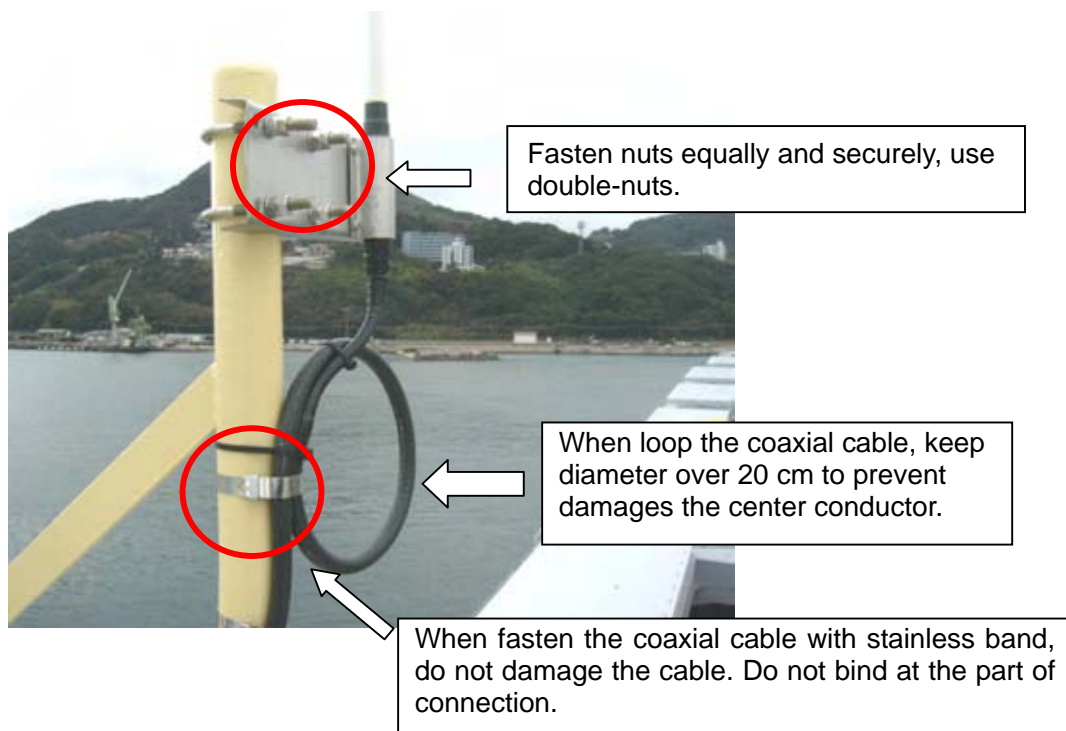

Fig. 4.1.3 Fixing Antenna

4.2 Installation of VHF Console

The Emergency lamp powered by the reserve source is required to illuminate the control panel.

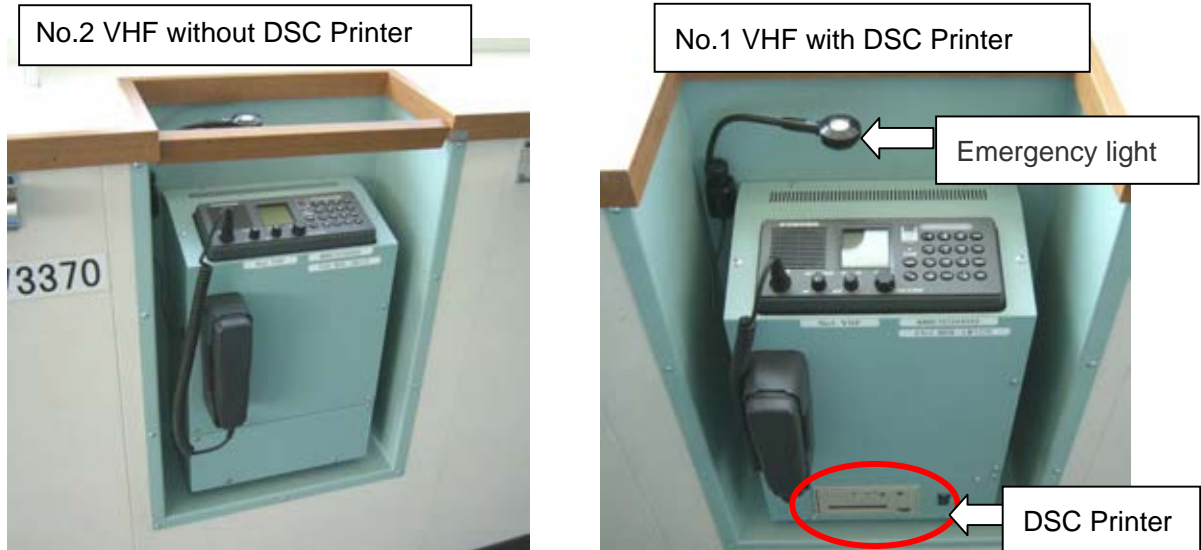

Fig. 4.2.1 VHF console

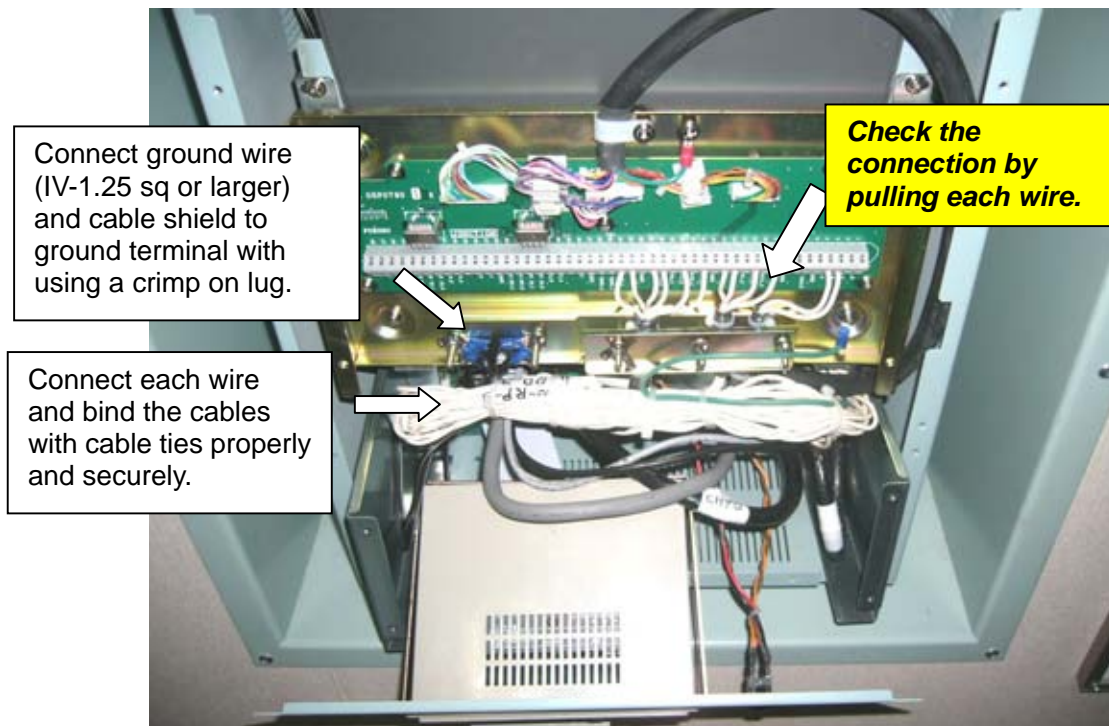

Fig. 4.2.2 Wiring in the VHF console

Wiring to terminal

1. Remove sheath 5 to 6 mm.
2. Set a terminal opener, insert the center conductor in terminal with pushing up .
3. After inserting, check the connection by pulling each wire.

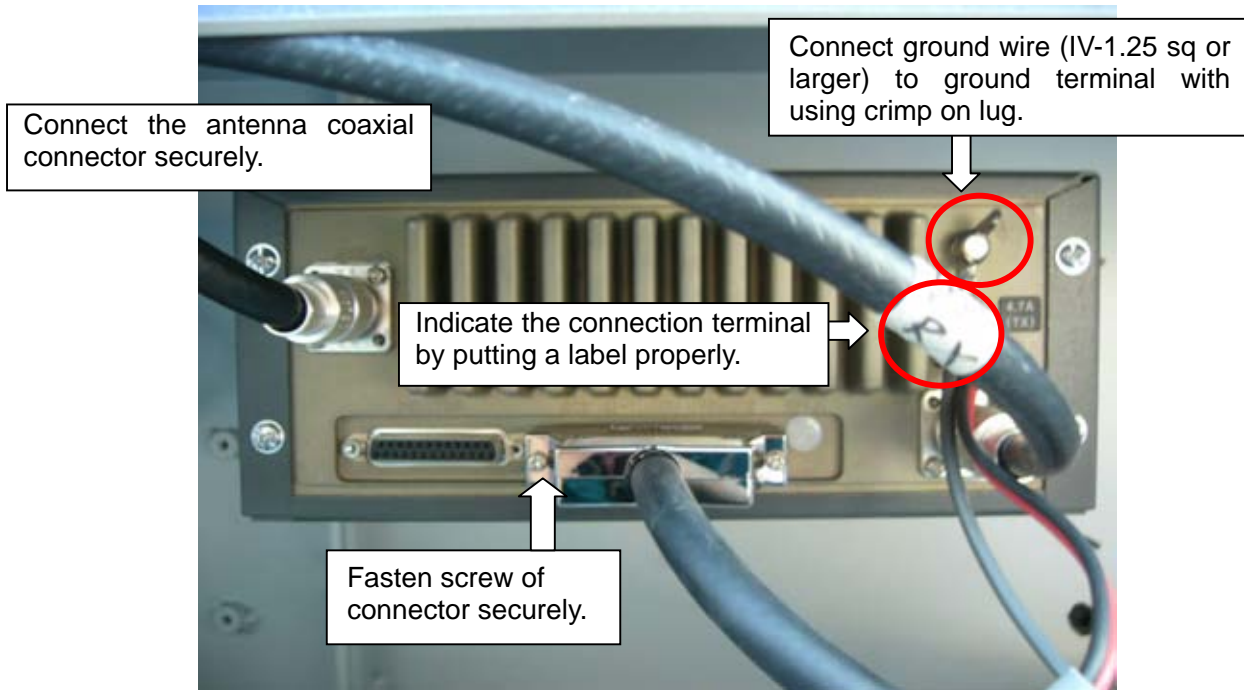
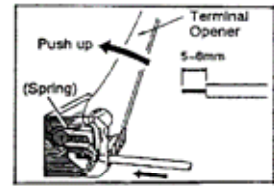

Fig. 4.2.3 Connection of VHF Console

Improper fabrication of M-type connector

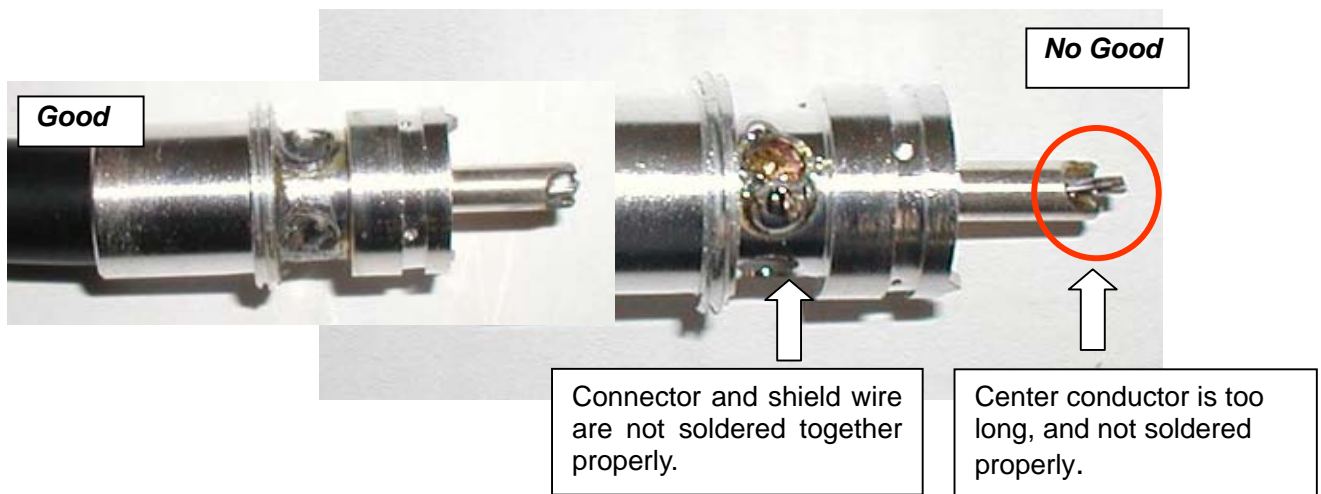

Fig. 4.2.4 Improper making of M-type coaxial connector

4.3 Installation of Remote Station

Maximum 4 remote stations are connected to the junction box.

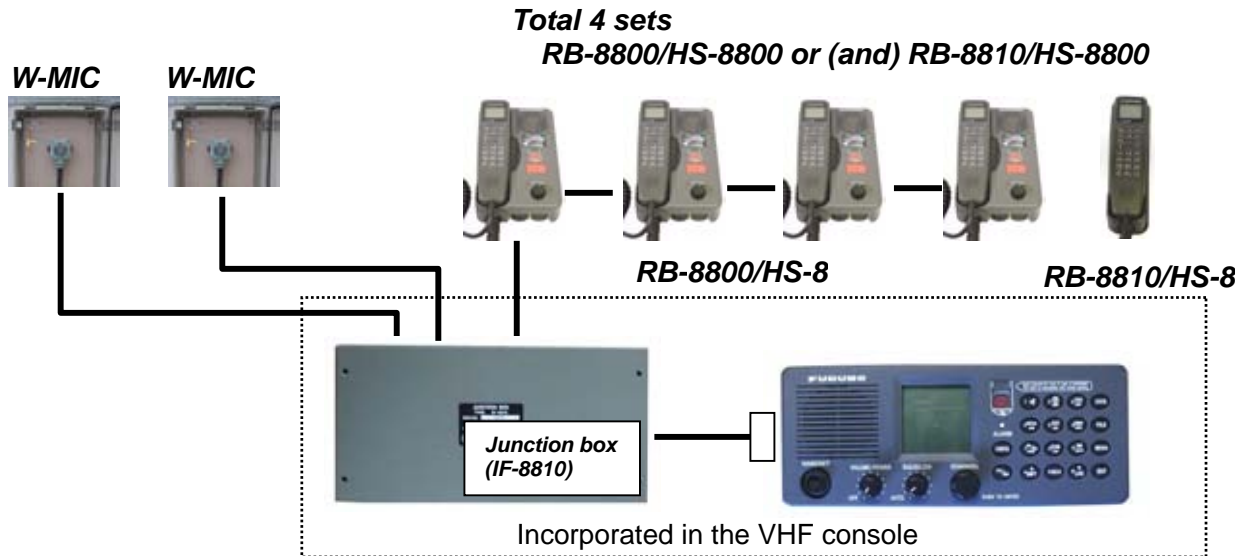

Fig. 4.3.1 Connection of remote station

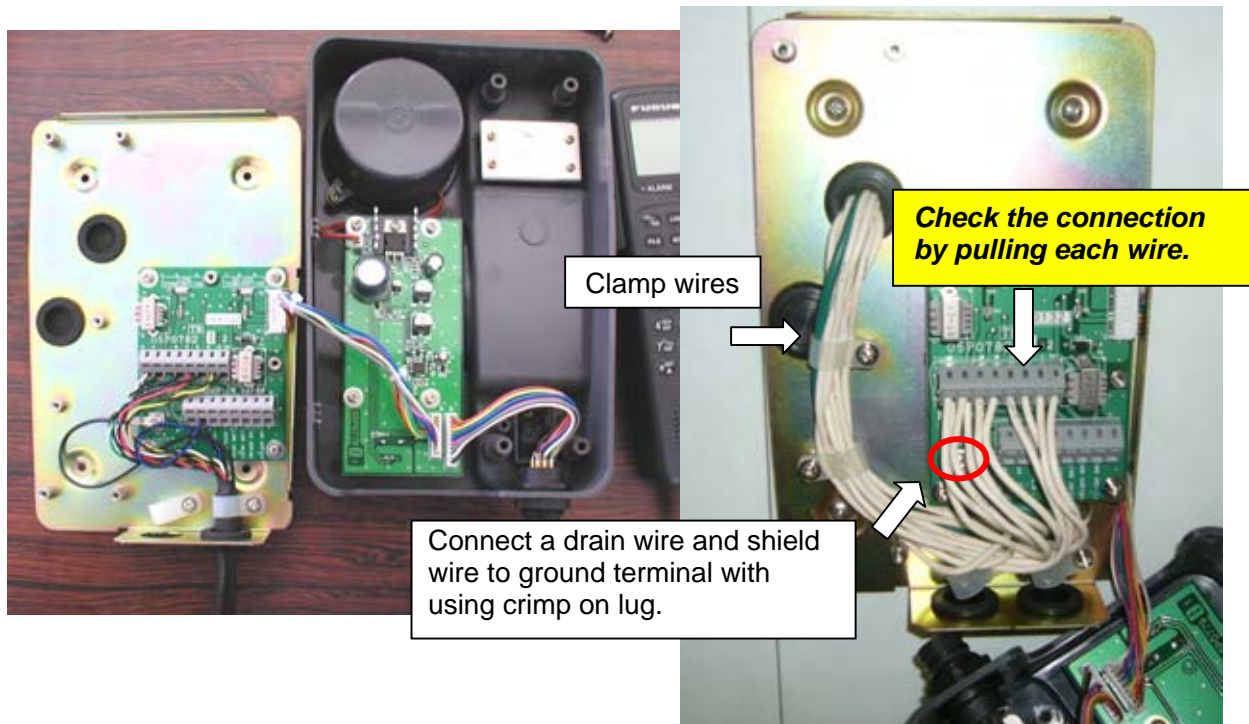

Fig. 4.3.2 Installation for Remote Station: RB-8800/HS-8800

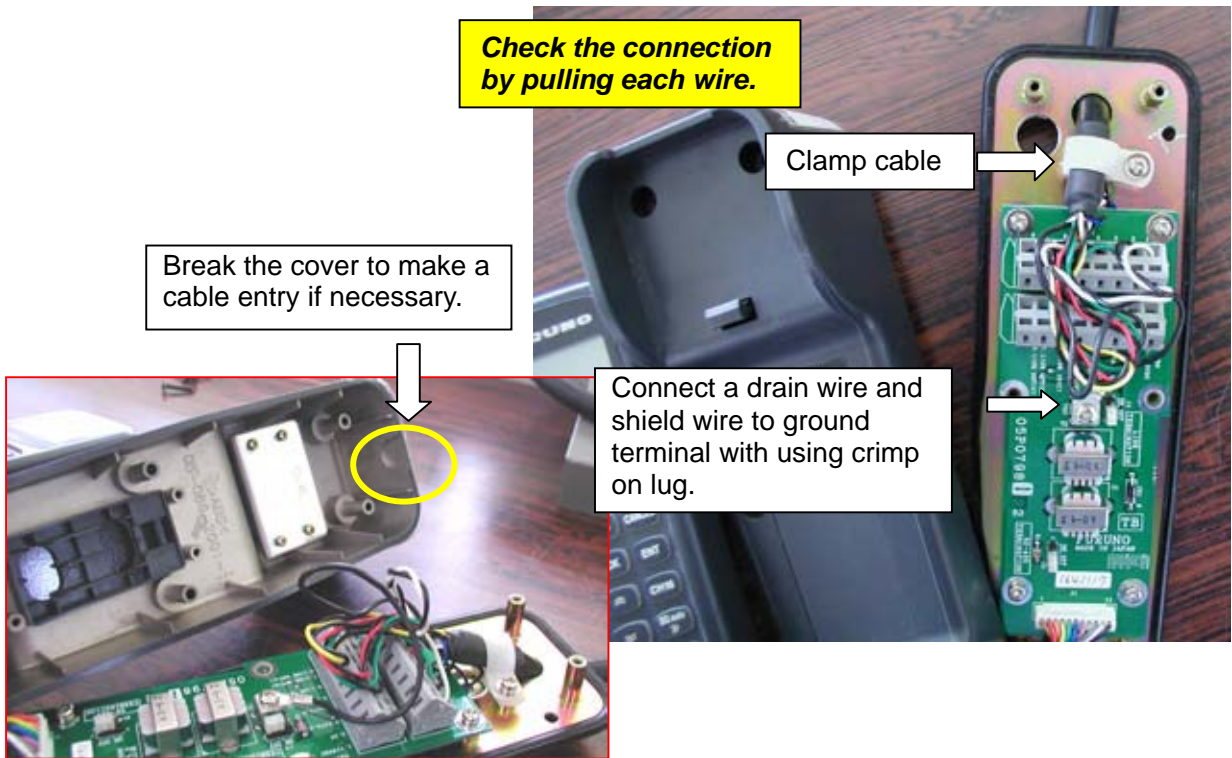

Fig. 4.3.3 Remote station: RB-8810/HS-8800

Set jumpers in the last remote station, the end of line, as shown bellow.

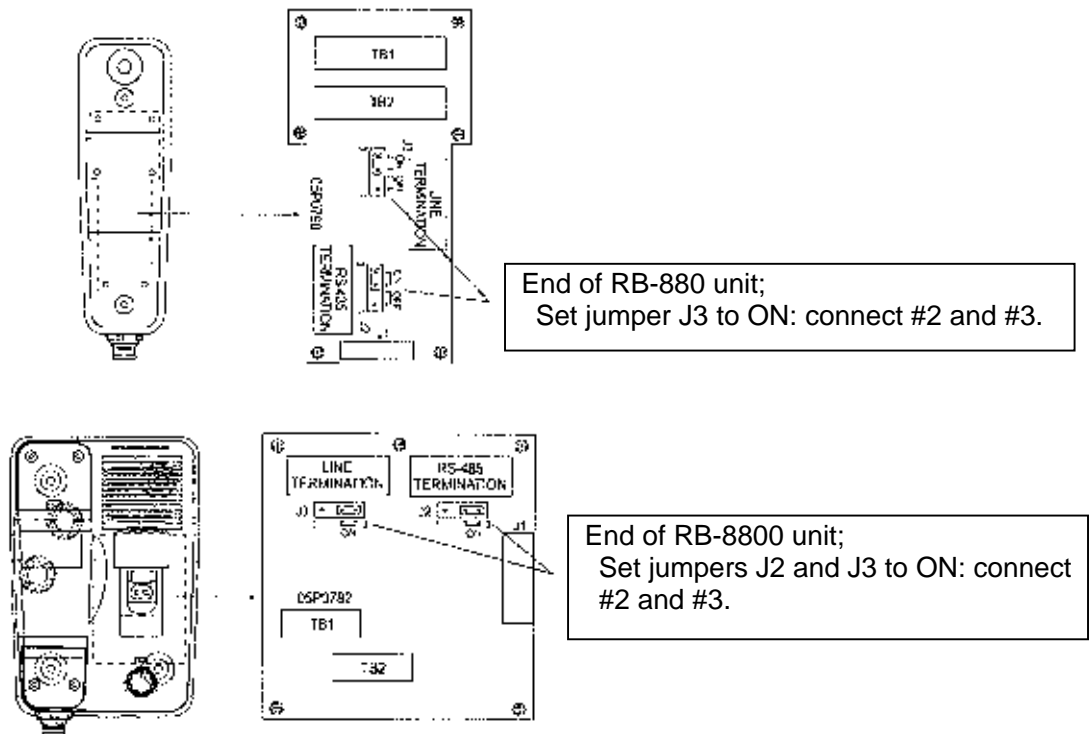

Fig. 4.3.4 Connection of Remote Station: RB-8810/HS-8800

4.4 Installation of VHF Wing Handset

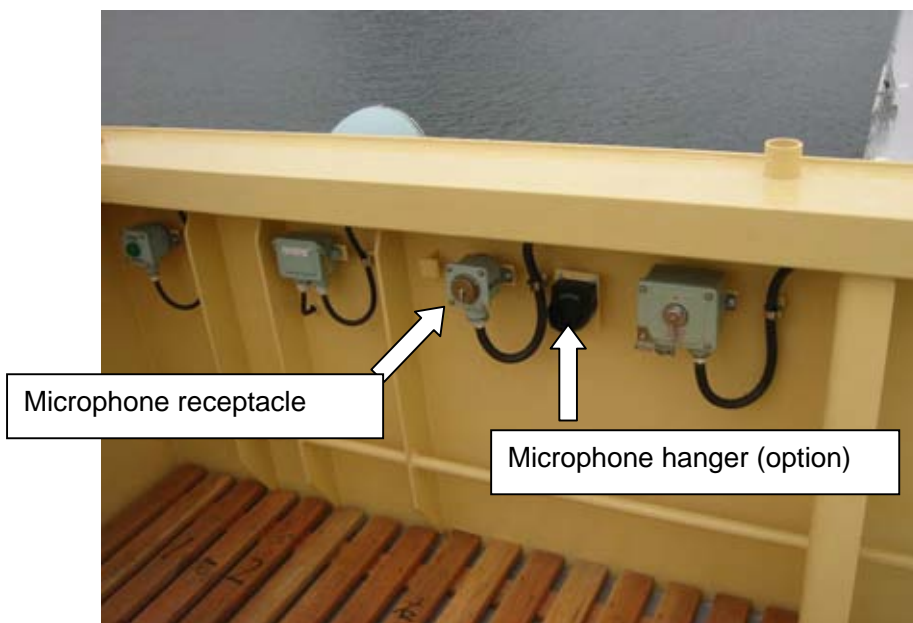

Fig. 4.4.1 Installation of wing handset Case 1

The handset is installed in a watertight box to prevent it from corroding.

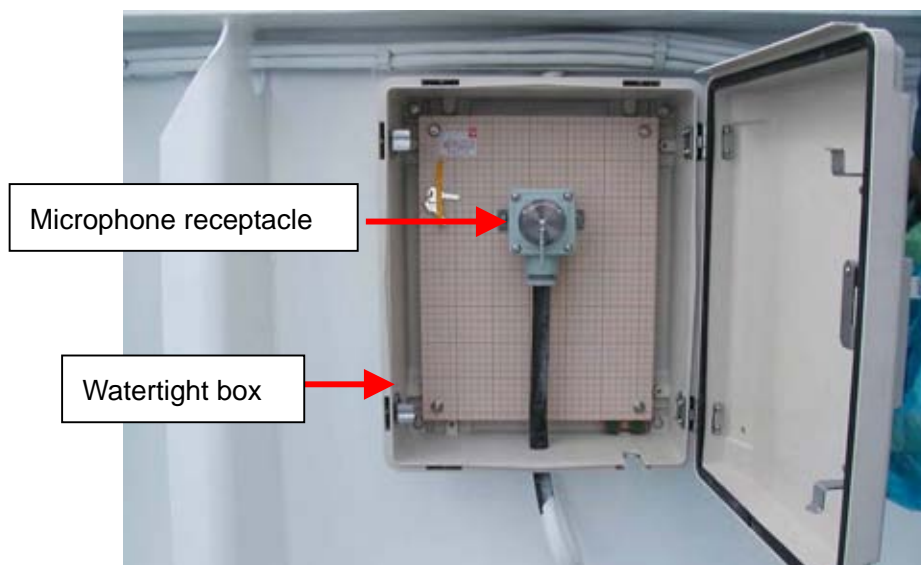

Fig. 4.4.2 Installation of wing handset Case 2

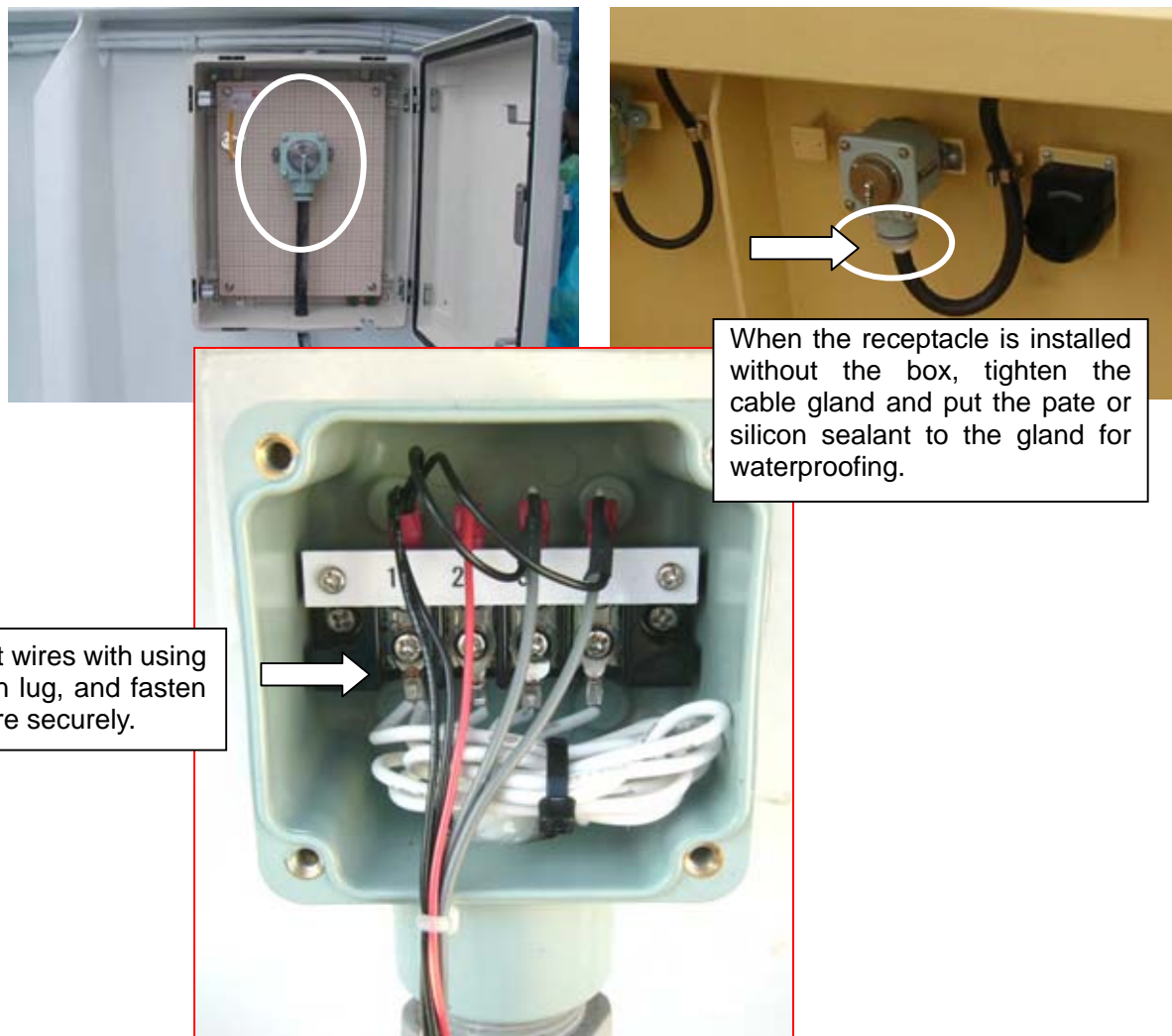

Fig. 4.4.3 Wiring in the handset receptacle

5.1 General installation of Inmarsat Antenna

Select the location where it will have a good view of the sky in all directions and also select a location of low vibration.

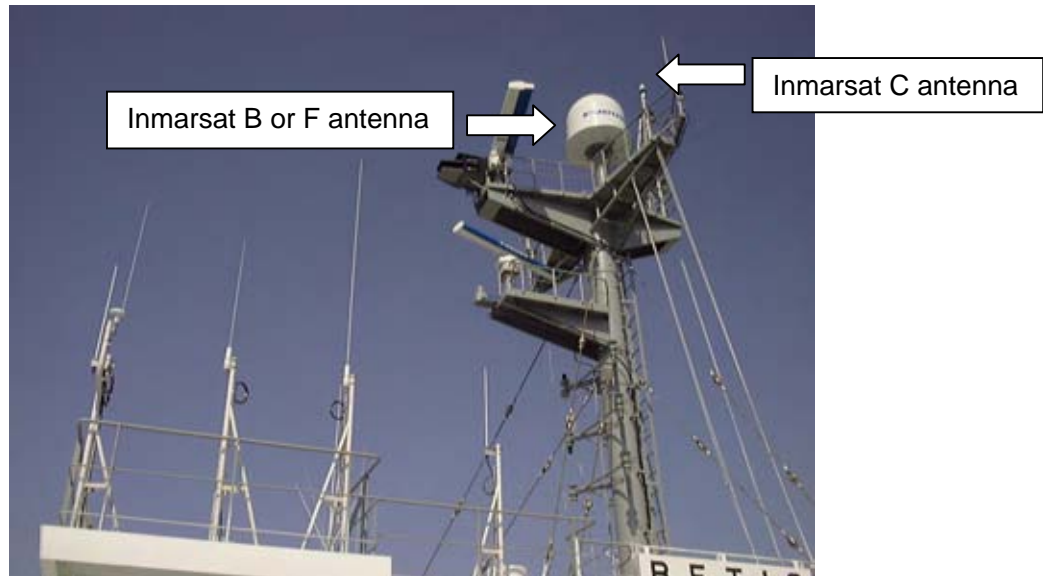

Fig. 5.1.1 Antenna installation-1

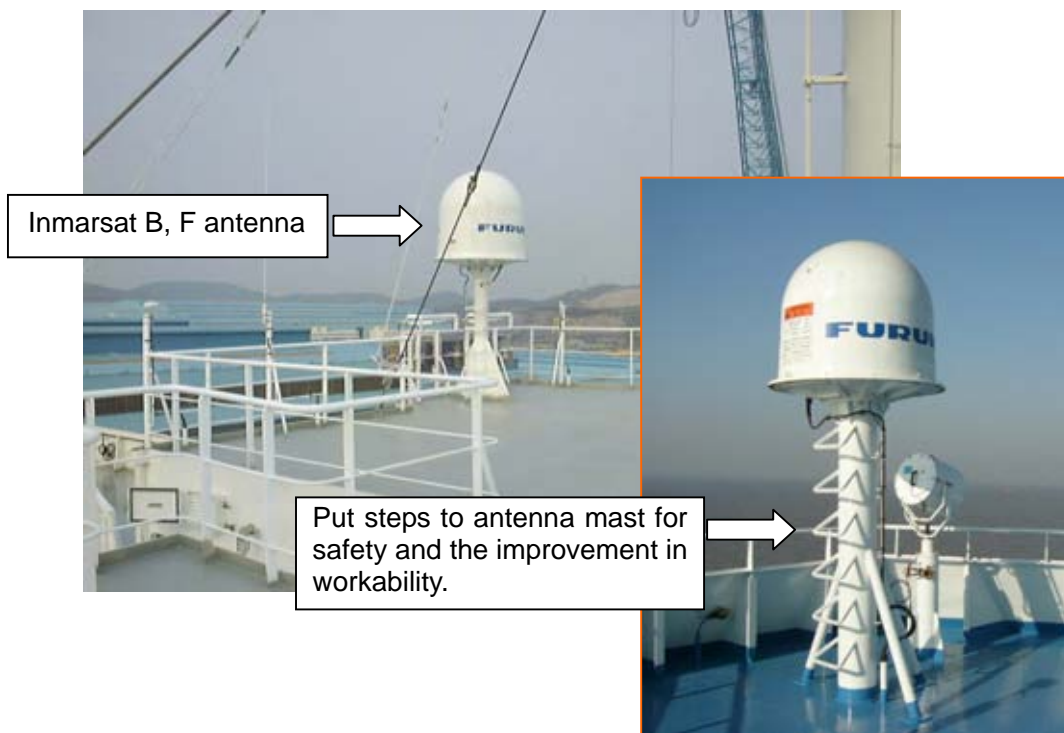

Fig. 5.1.2 Antenna installation-2

5.2 Installation of INMARSAT B

5.2.1 Antenna unit

- * Select the location where it will have a good view of the sky in all directions.
- * Select a location of low vibration
- * Never put rubber mat between the mounting base and the antenna base.
- * Do not cover the drain hole.

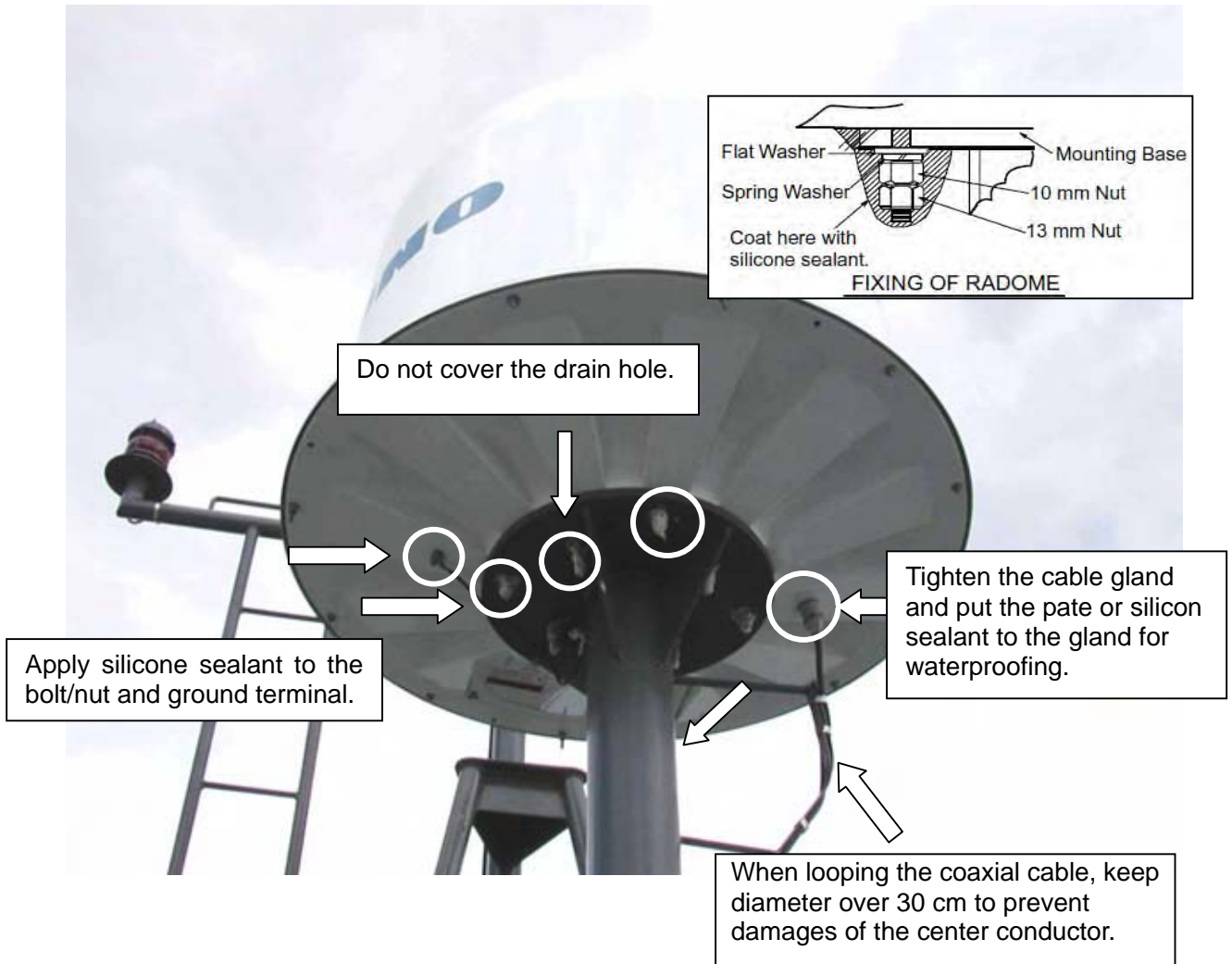

Fig. 5.2.1 Mounting of antenna unit

5.2.2 Radio frequency Radiation hazard label

Install the safety fence keeping distance (6 m) from antenna to separate the antenna from humankind. And, put label keeping distance (6 m) from antenna, so that one can notice RF radiation hazard.

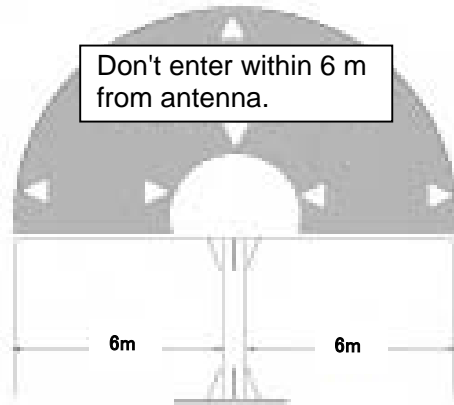

Fig. 5.2.2 Safety Zone

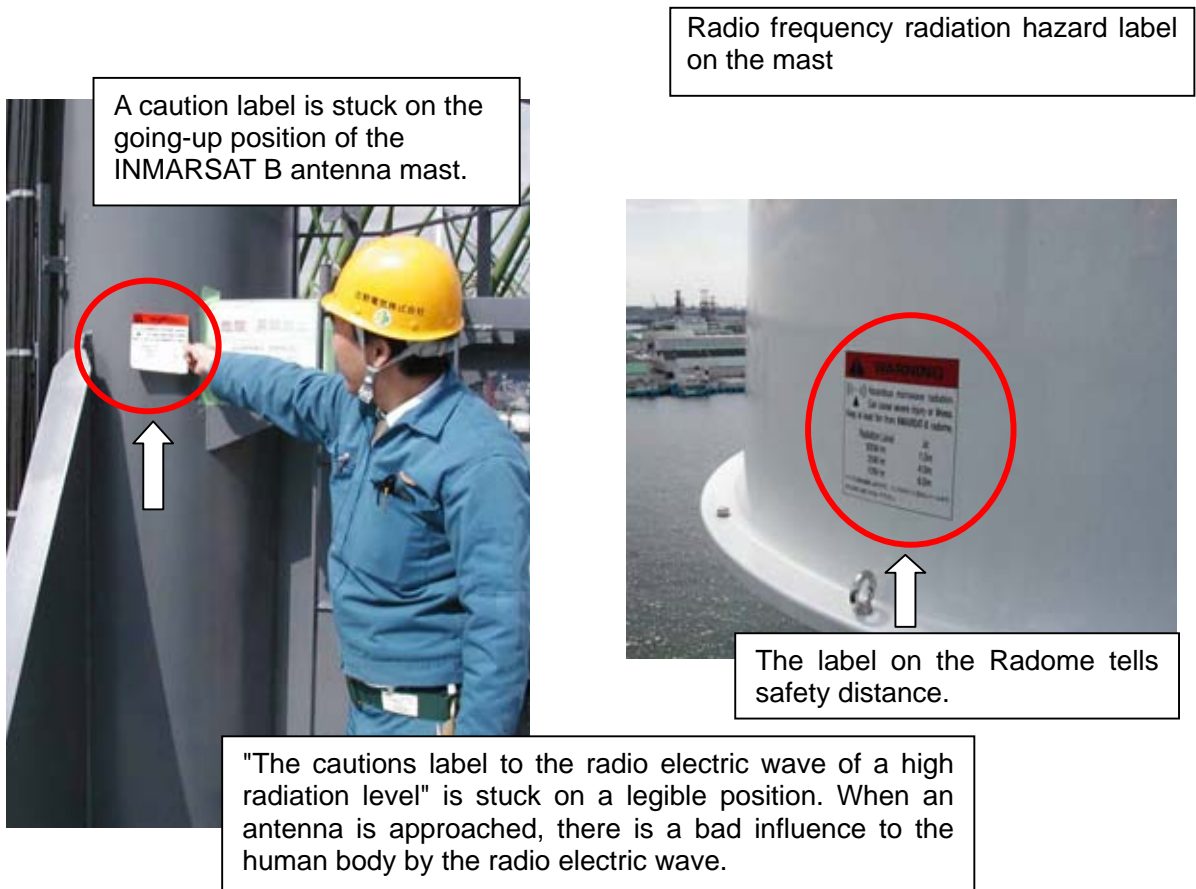

Fig. 5.2.3 Caution label

5.2.3 Connecting Coaxial cable in Radome (FELCOM 82)

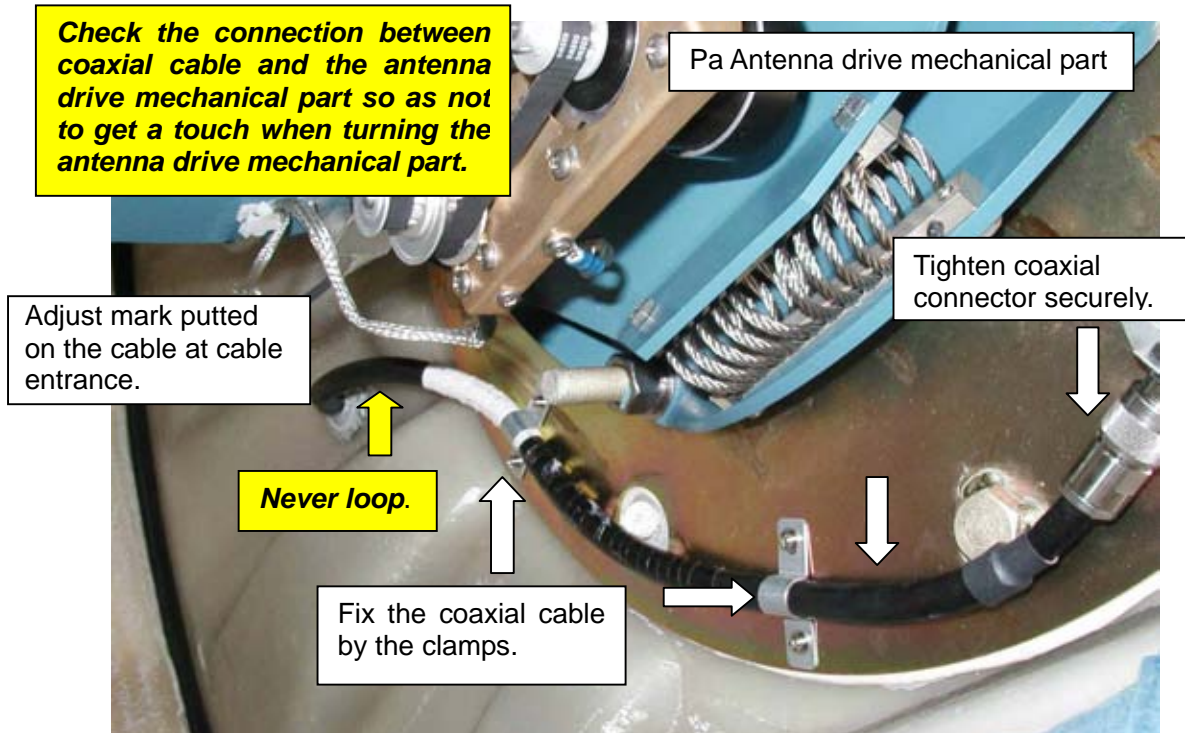

Fig. 5.2.4 Connecting cable in the Radome

5.2.4 Installation of Transceiver unit and Junction box

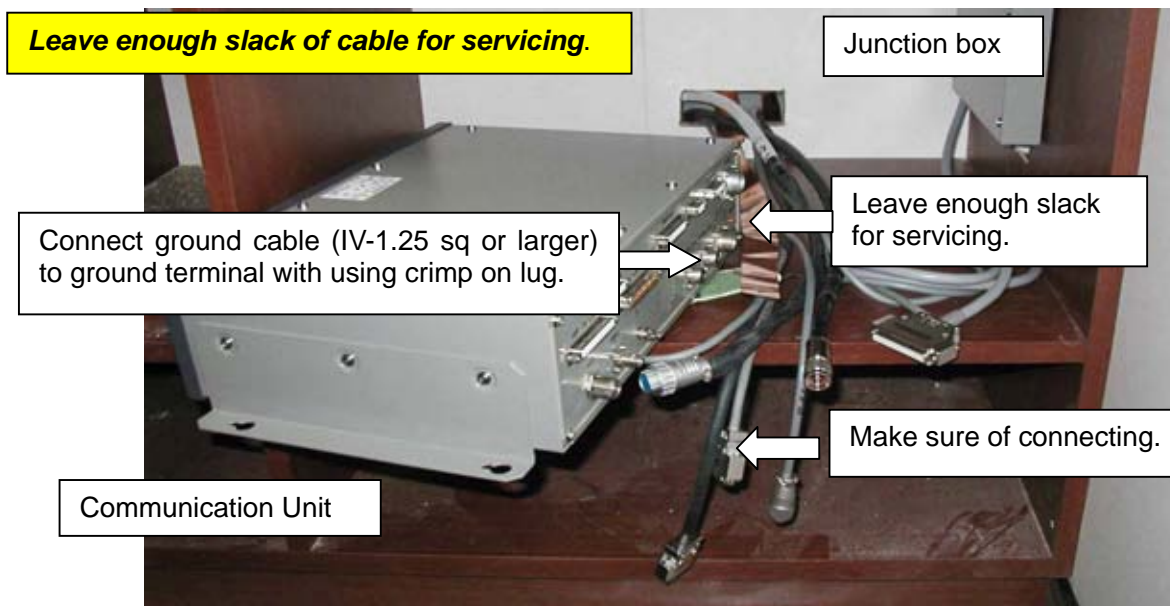

Fig. 5.2.5 Communication Unit

5.2.5 Mounting of FELCOM 82 Handset and TEL Distress Button unit

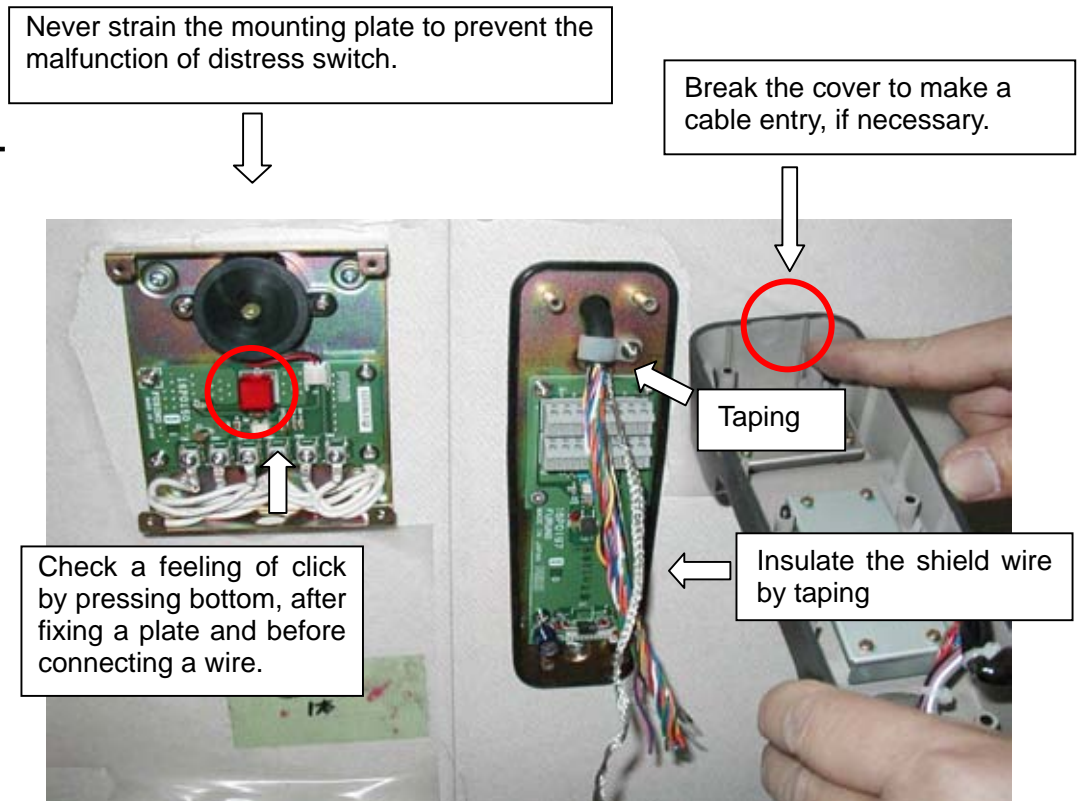

Fig. 5.2.6 Mounting of Handset and TEL DIS Button unit

5.3 Installation of INMARSAT C

5.3.1 Mounting of Antenna unit

- * Installation site: Select the location where it will have a good view of the sky in all directions. Select a location of low vibration
- * Weld the antenna mounting pipe directly to the antenna pole. Mounting it with clamps is not recommended.
- * Apply silicone sealant to the bolt, nut, grounding point and terminal.
- * The diameter of the service (drip) loop must be 30 cm or more.
- * Do not cut or shorten the coaxial cable supplied.

1. Fixing antenna

1. Apply silicone sealant (local supply) to the threads of the pipe.
2. Unscrew three screws to remove the antenna base from the antenna unit.
3. Pass the cable assy TPA5FB0.3NJ5FBA-5DFB (supplied, 300 mm) into the shrink tube (SCM2, supplied).
4. Attach the above cable assy to the connector at the bottom of the antenna unit (upper).
5. Shift up the shrink tube until it touches the bottom of the antenna unit (upper).
6. Heat the shrink tube, and then apply silicone sealant to the upper edge of the tube, also wind self-bonding tape around the lower edge of the shrink tube and then wrap vinyl tape over self-bonding tape.

Note: Between the bottom of the antenna unit (upper) and the end of the taping should be less than 50 mm.

7. Insert the cable protector (supplied) in to the slot at the bottom of the antenna base.
8. Pass the antenna cable through the pipe and antenna base in order. When laying the cable along side the pipe, put the cable aside to pass through the projection in the antenna base.

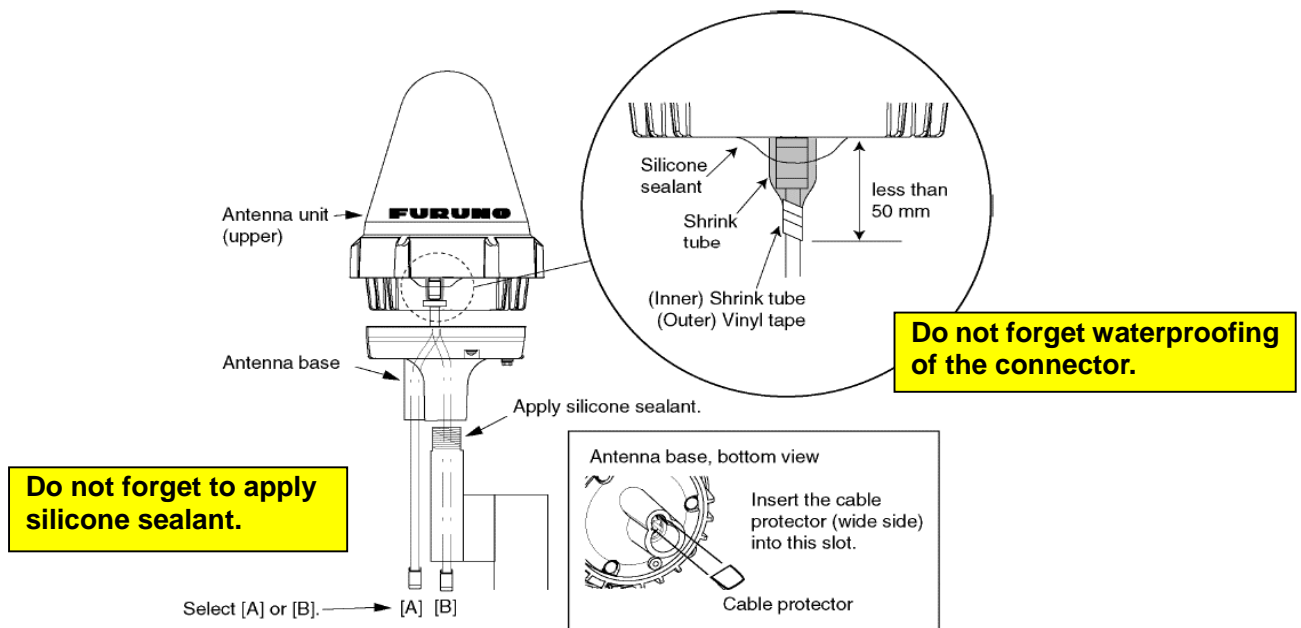

Fig. 5.3.1 Before installing the antenna

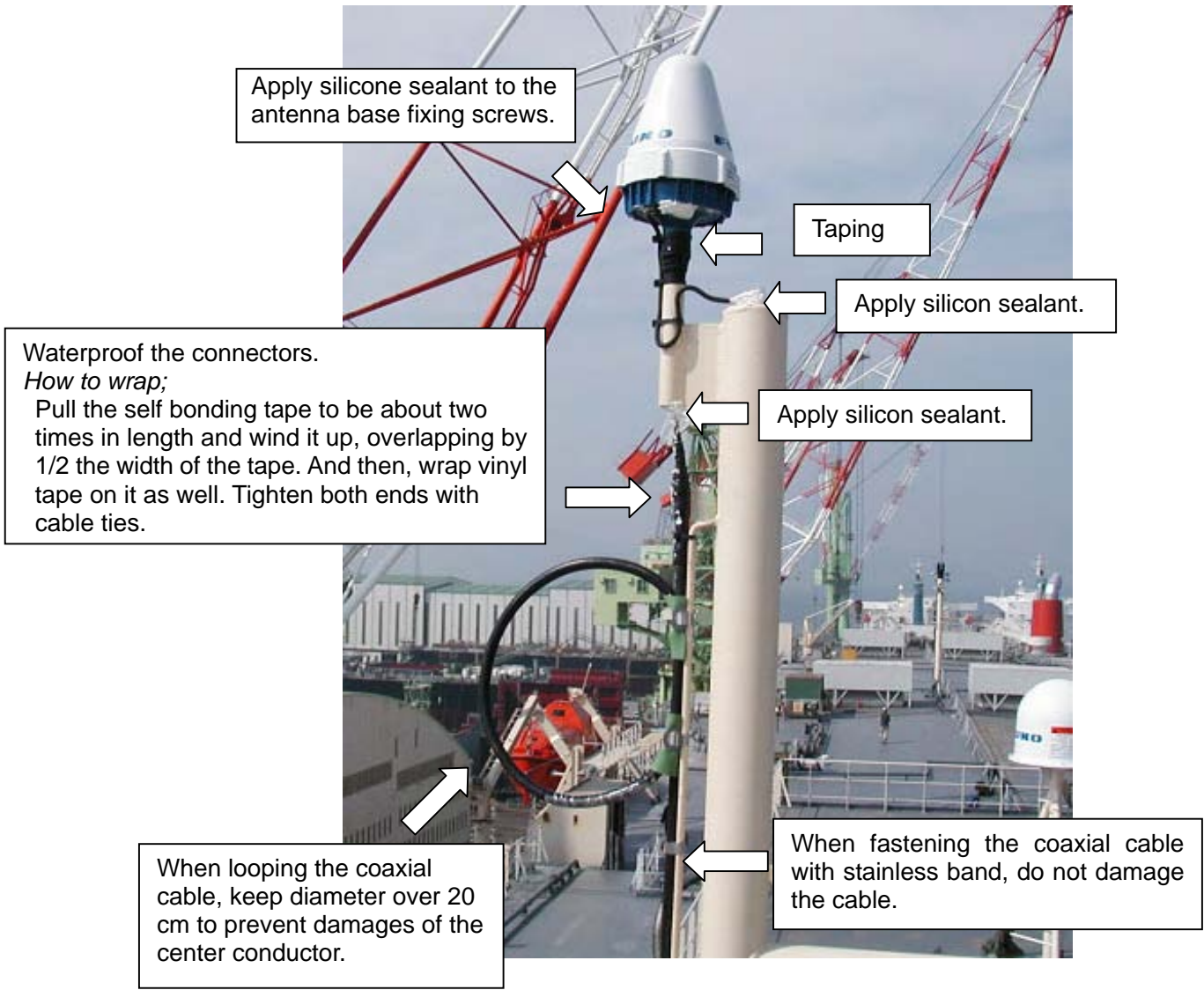
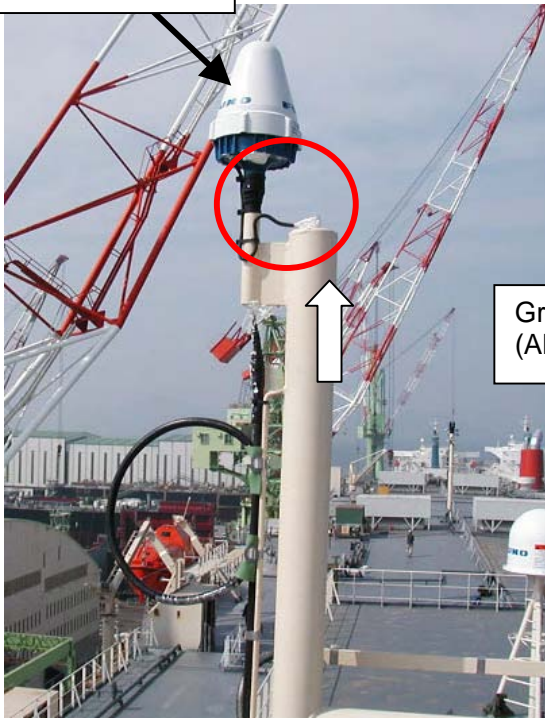

Fig. 5.3.2 Mounting of Antenna

2. Sample of Antenna Installation

In case that the cable is passed through pipe;

Apply silicone sealant to the antenna base fixing screws.



Ground (RW4747) (Alongside of the pipe)

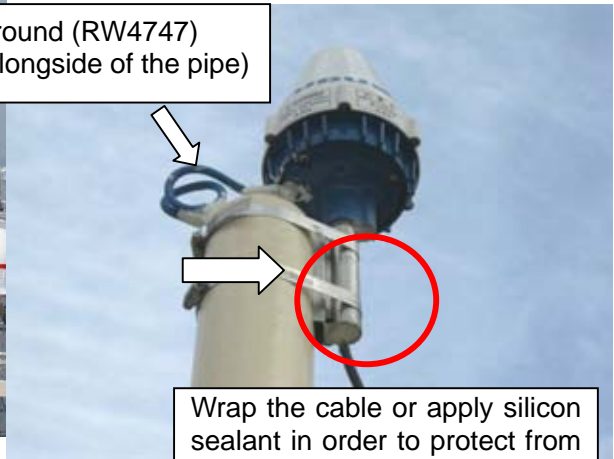

Wrap the cable or apply silicon sealant in order to protect from scratching by the edge of pipe.

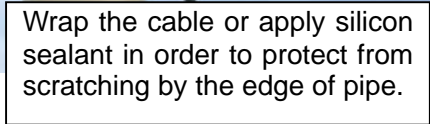

Wrap the cable or apply silicon sealant in order to protect from scratching by the edge of pipe.

Fig. 5.3.3 Example of the installation through the pipe

In case that the cable is fixed alongside the mast;



Ground wire (RW4747) (Alongside of the pipe)

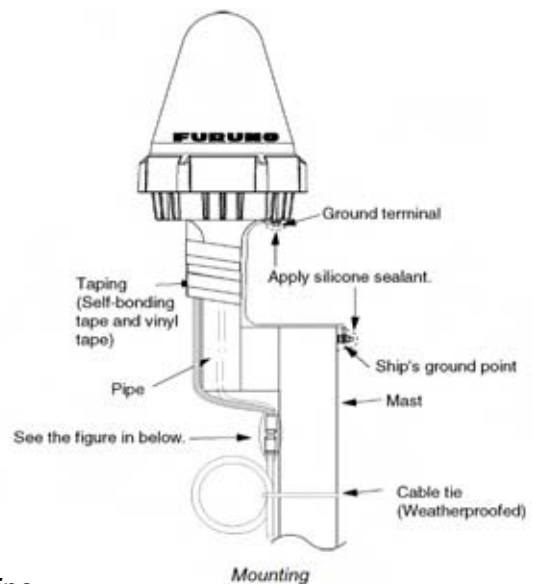

Fig. 5.3.4 Example of the alongside of the pipe

5.3.2 Mounting of Terminal unit

1. Connection in the radio console

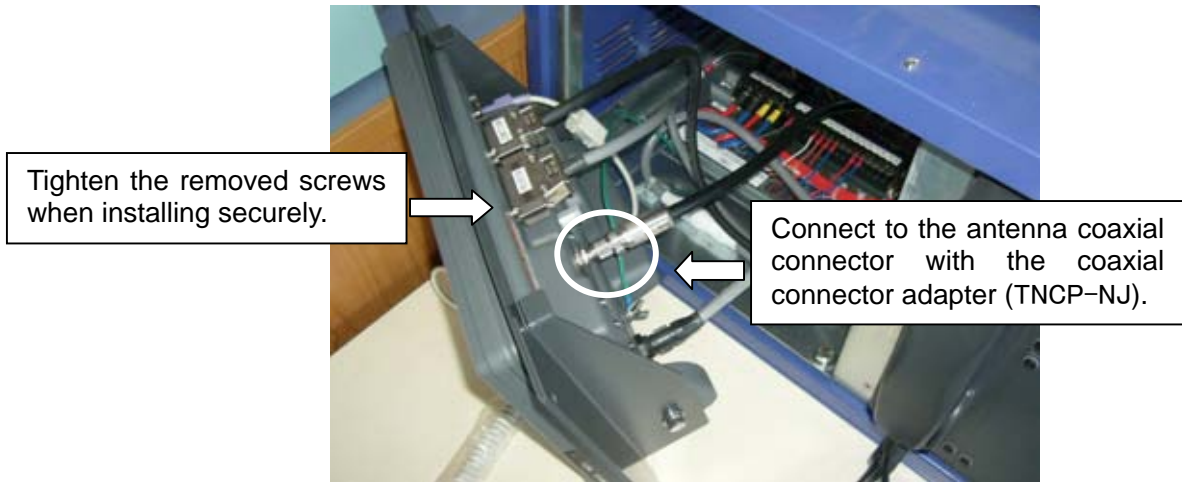
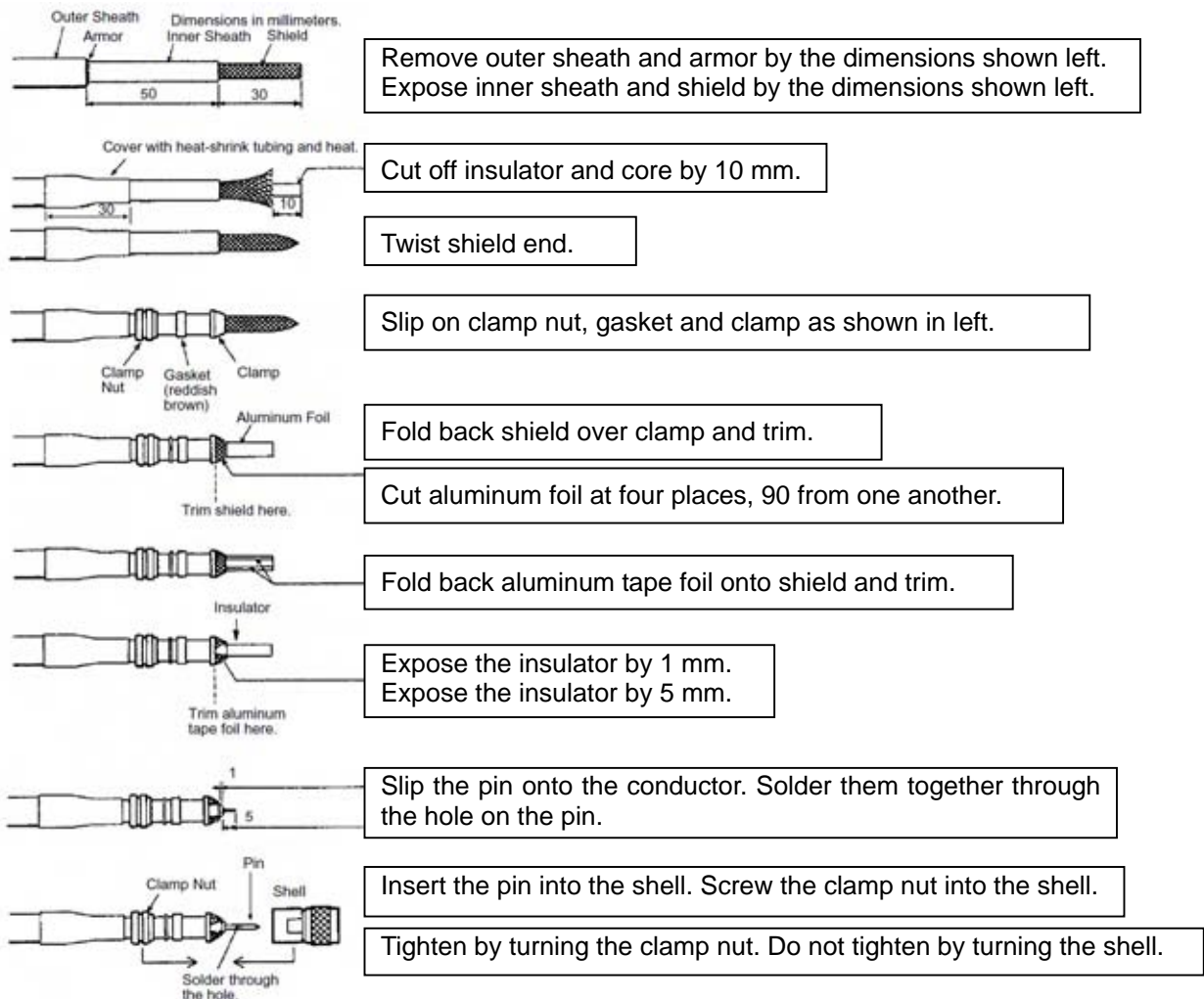

Fig. 5.3.5 Connecting connectors

Fabrication of N-P-8DFB connector



2. Junction Box (IC315), Distress alert/Received call unit (IC305) and Alarm unit(IC306)

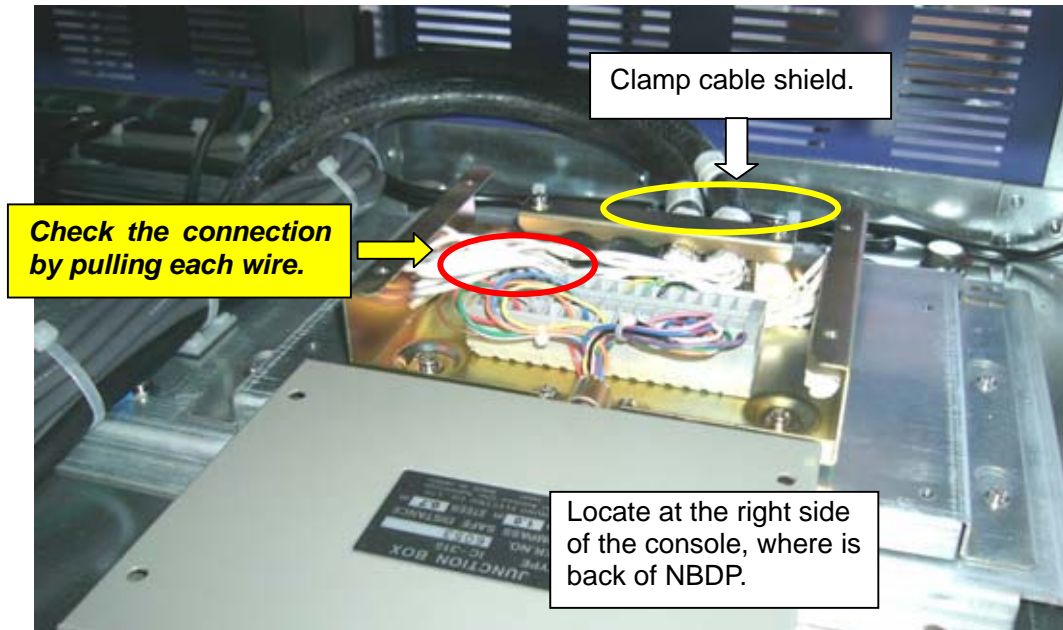

Fig. 5.3.6 Wiring of junction box

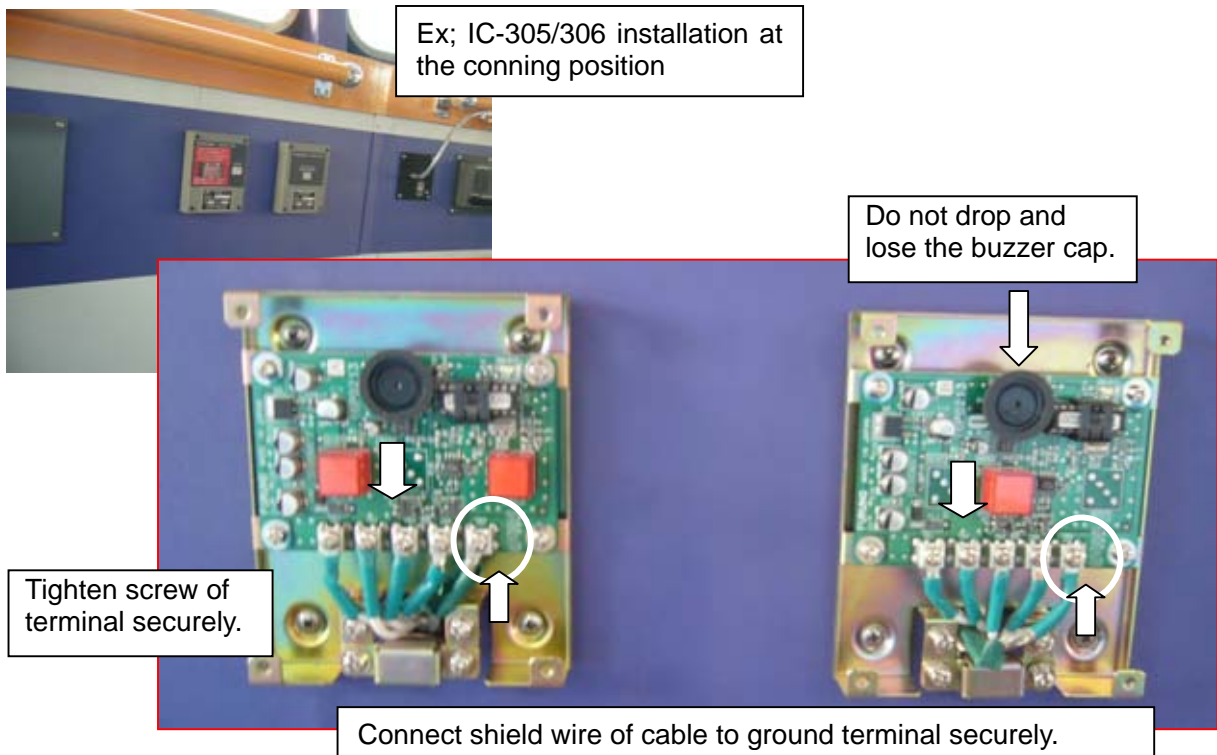

Fig. 5.3.7 Distress Alert/Received Call Unit and Alarm Unit

5.3.3 Installation of SSAS unit

1. Antenna

When installing FELCOM 16 as SSAS equipment,

Because FELCOM 16 is not GMDSS corresponding equipment, the antenna location is not required to GMDSS requirement. However, select the place in good view of sky such as compass deck.

Notice of antenna installation

1. When installing the both antenna of FELCOM 15 and 16 at the closed place. Keep distance at least 1.5 m between them having level difference more than 40 cm (15 degrees down from another antenna).
2. Keep distance more than 5 m between the antennas of FELCOM 15/16 and the terminal unit "IC-215".
3. Keep distance more than 3 m between the antennas of FELCOM 15/16 and the communication unit "IC-216" of FELCOM 16.

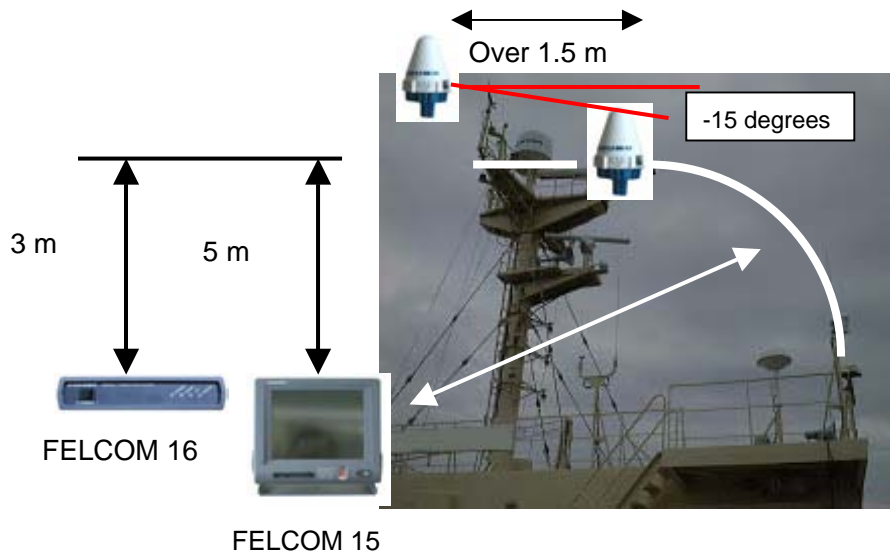

Keep distance more than 3 m between the antennas of FELCOM-15/16 and the communication unit "IC-216" of FELCOM-16.

Fig. 5.3.8 Relationship among antennas and terminal/communication units

2. Mounting of FELCOM 16 Communication unit

The communication unit and junction box of FELCOM 16 are installed in the place where is not conspicuous, such as storage space.

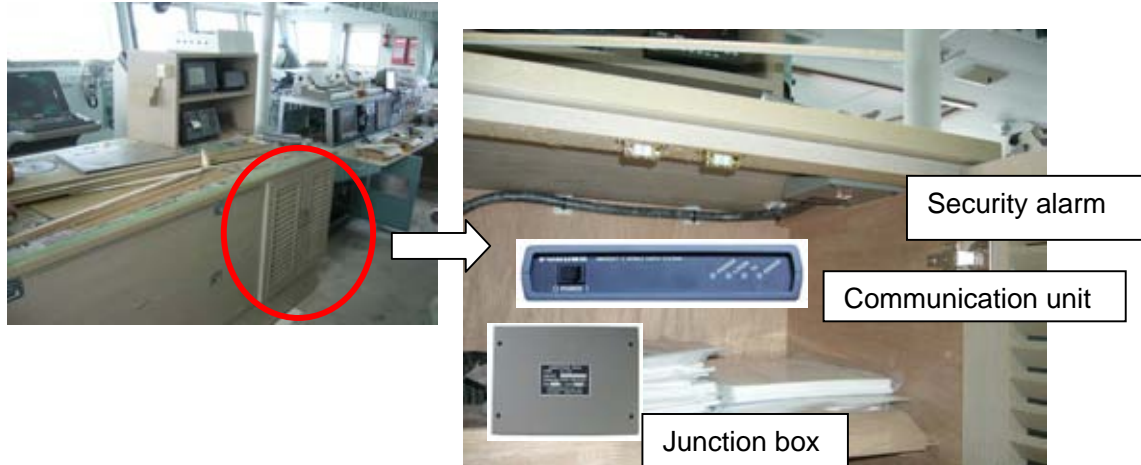

Fig. 5.3.9 Installation of communication unit and junction box

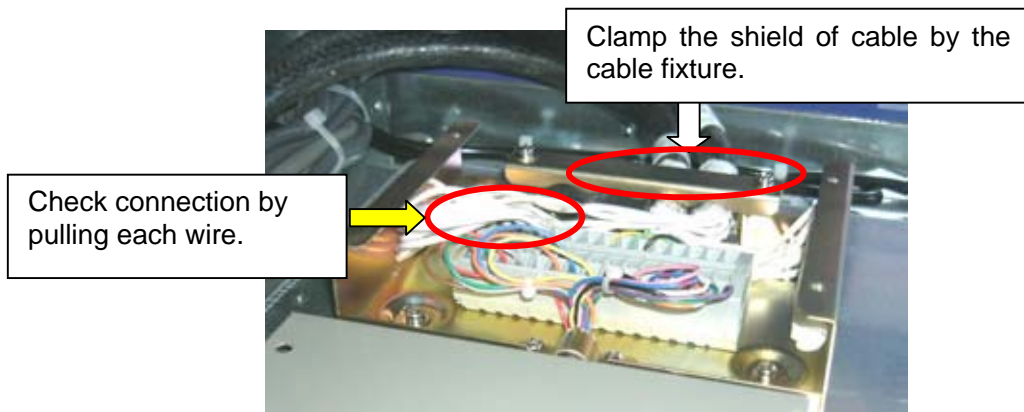

Fig. 5.3.10 Wiring in junction box

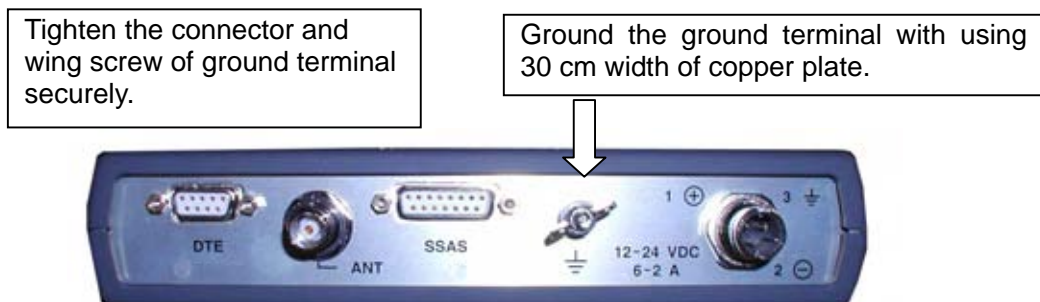

Fig. 5.3.11 Wiring of communication unit

3. Mounting of IC-307

The Security alert signal is generated from the bridge. In addition, it must be able to activate from one or more place except bridge.

Install the "IC-307" at the place where operator can easily press the switch, and at the place where it is not pressed carelessly.

Alert unit is installed at the place where it is not found by pirates easily, such as under the table near the radio console or under the table in the captain room.

Installation in the bridge

e.g.) Install IC-307 under the table near the radio console

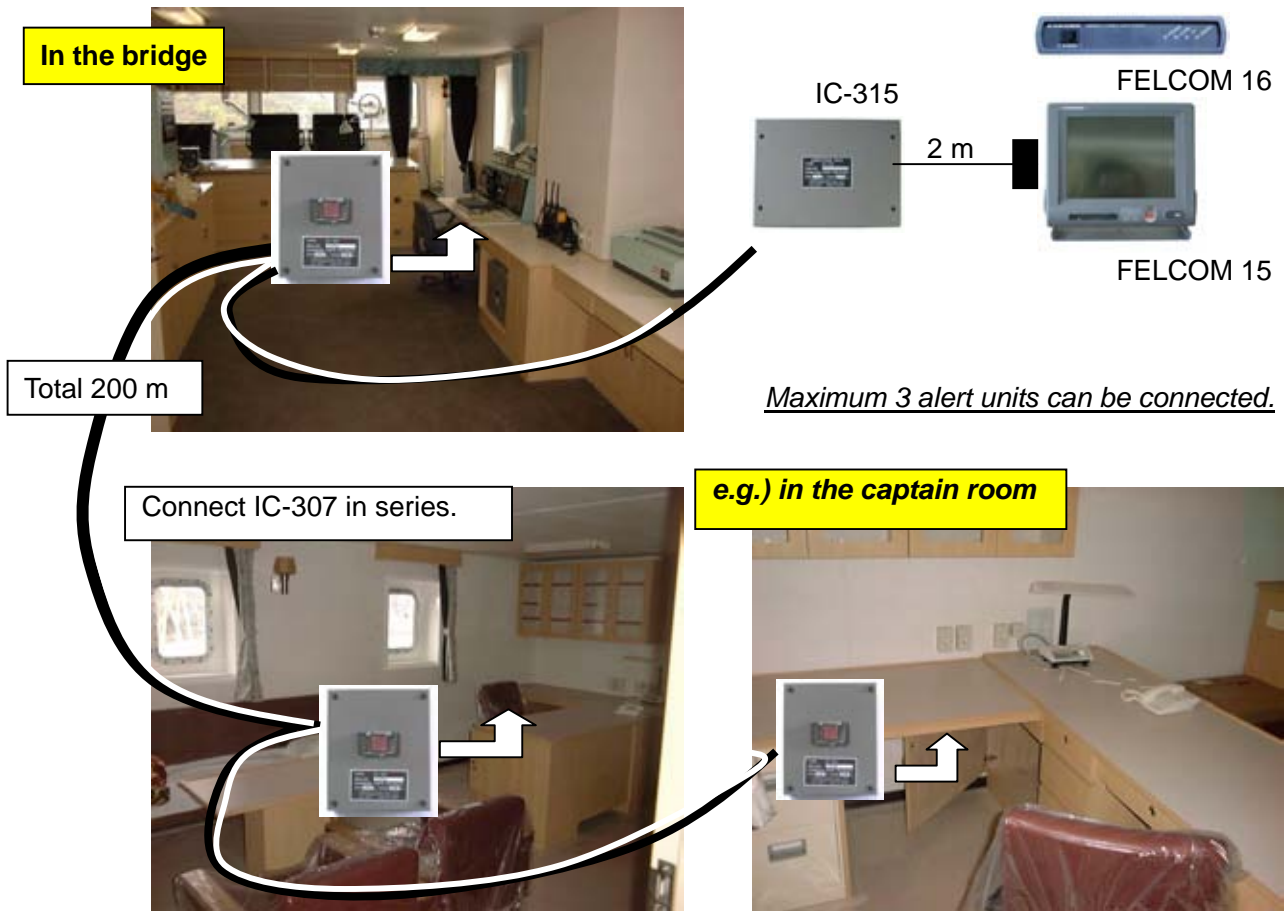

Another place of installation;
Under the table in the captain room

Fig. 5.3.12 Mounting of SSAS Alert Unit

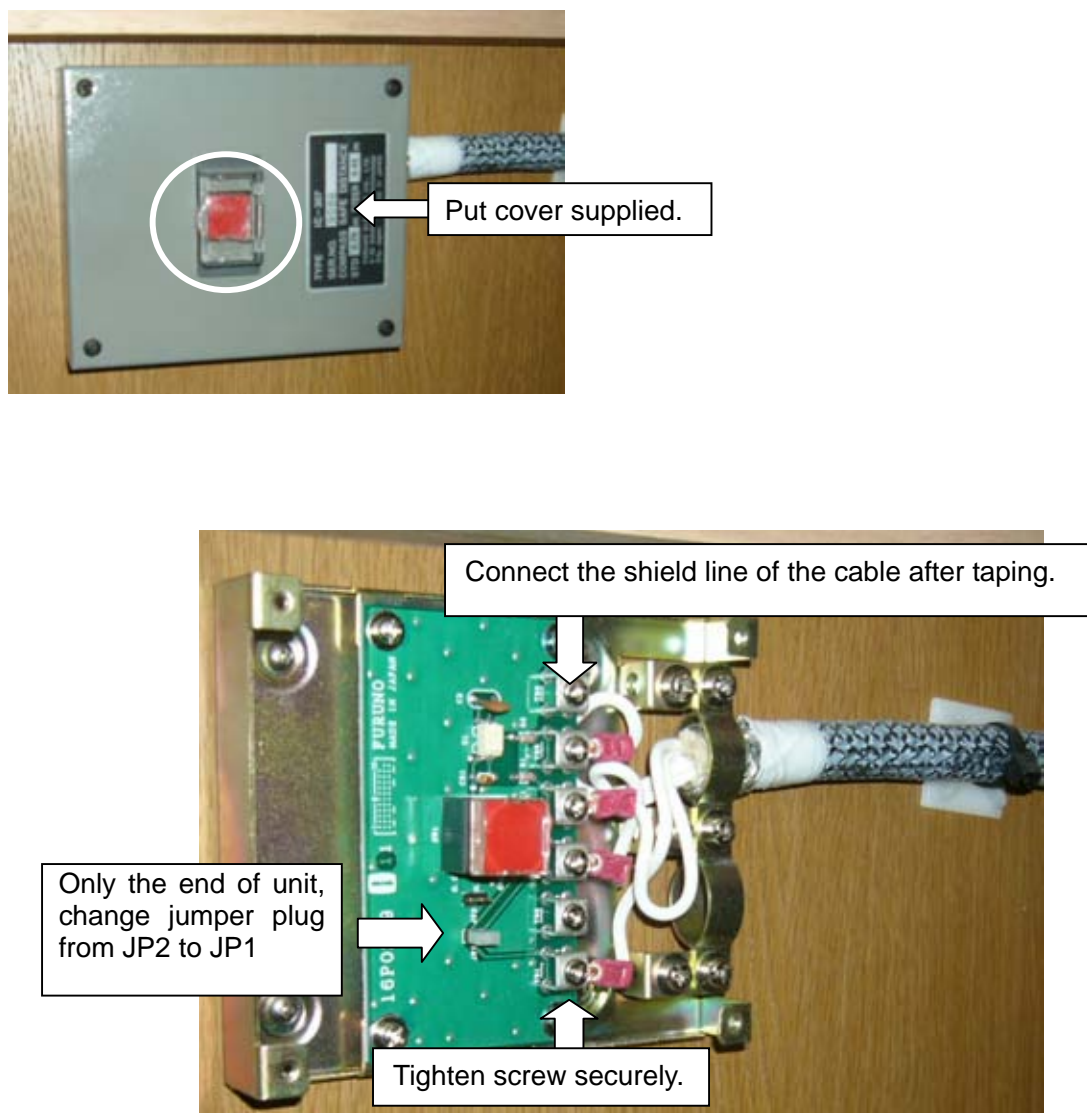

Fig. 5.3.13 Installation of SSAS Alert Unit

5.4 Installation of INMARSAT F

5.4.1 Mounting of Antenna unit

- * Select the location where it will have a good view of the sky in all directions.
- * Select a location of low vibration
- * Never put rubber mat between the mounting base and the antenna base.
- * Do not cover the drain hole.
- * For the antenna side, the connector is fixed to the coaxial cable.

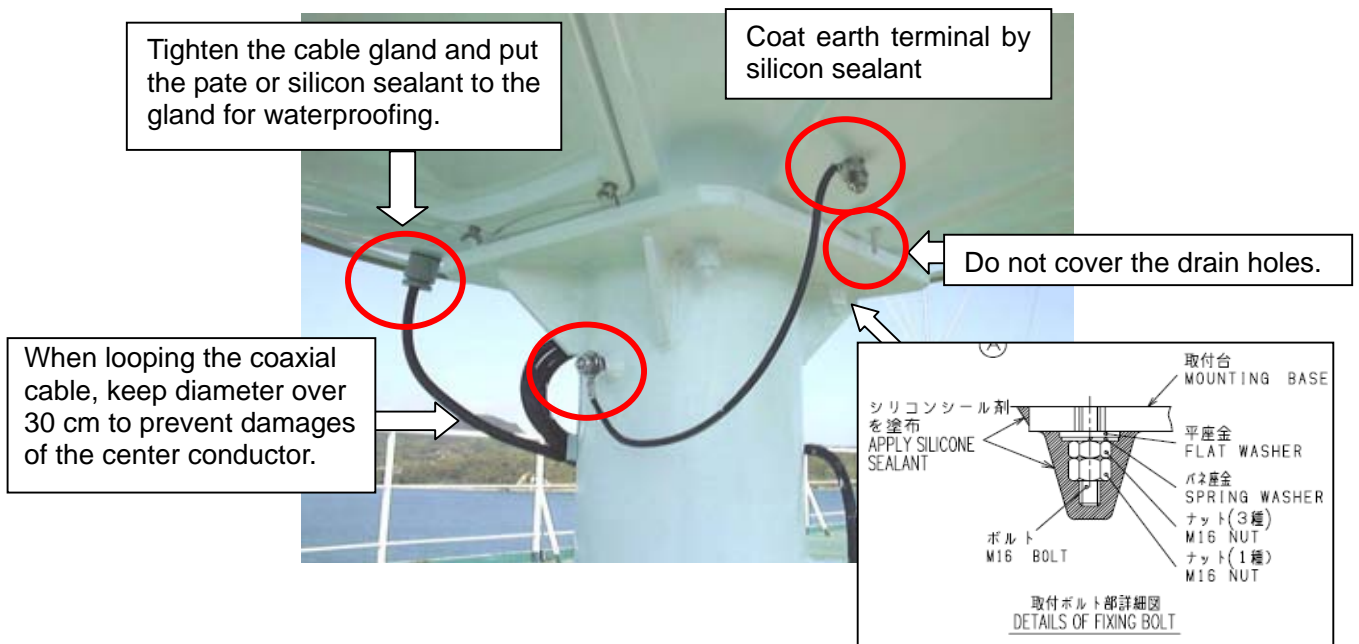

Fig. 5.4.1 Mounting of antenna unit

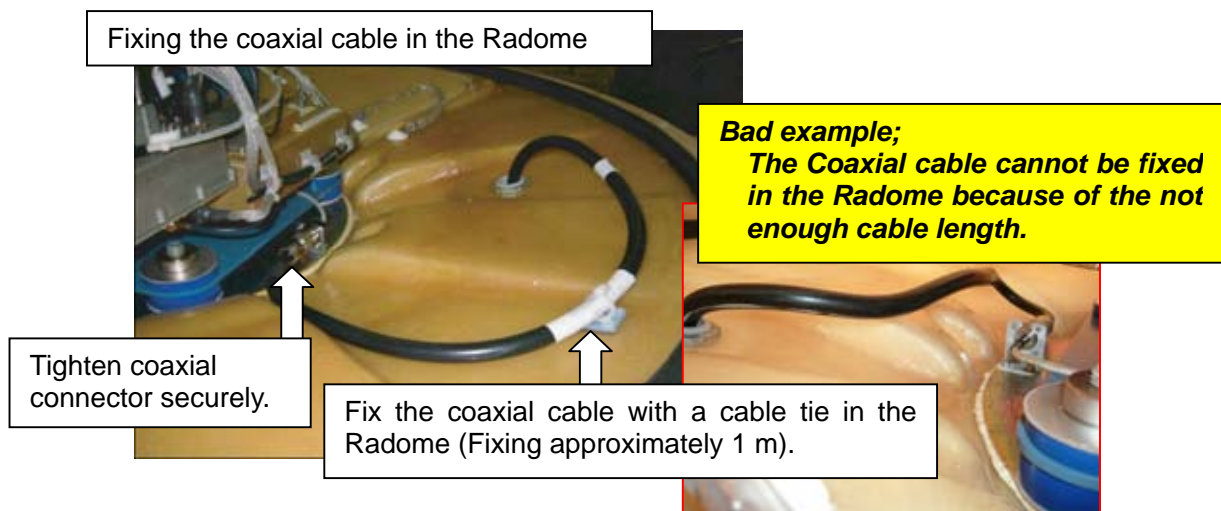

Fig. 5.4.2 Connecting cable in radome

5.4.2 Radio frequency Radiation hazard label

Install the safety fence keeping distance (4 m) from antenna to separate the antenna from humankind. And, put label keeping distance (4 m) from antenna, so that one can notice RF radiation hazard.

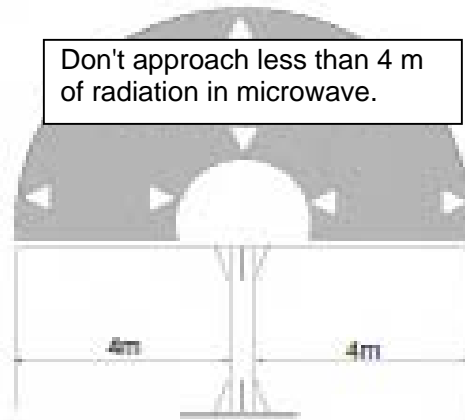

Fig. 5.4.3 Safety Zone

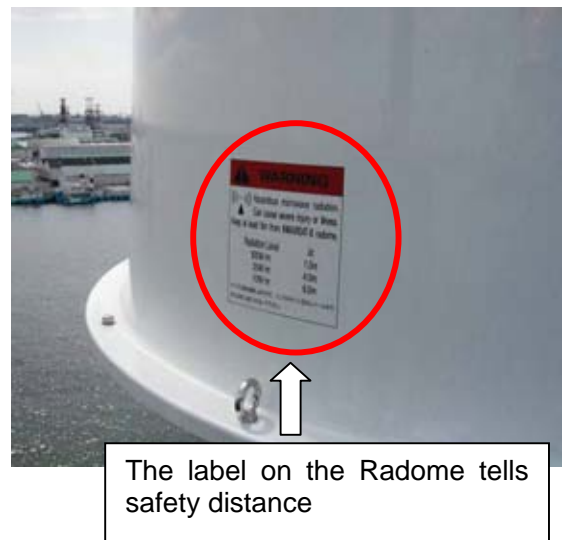
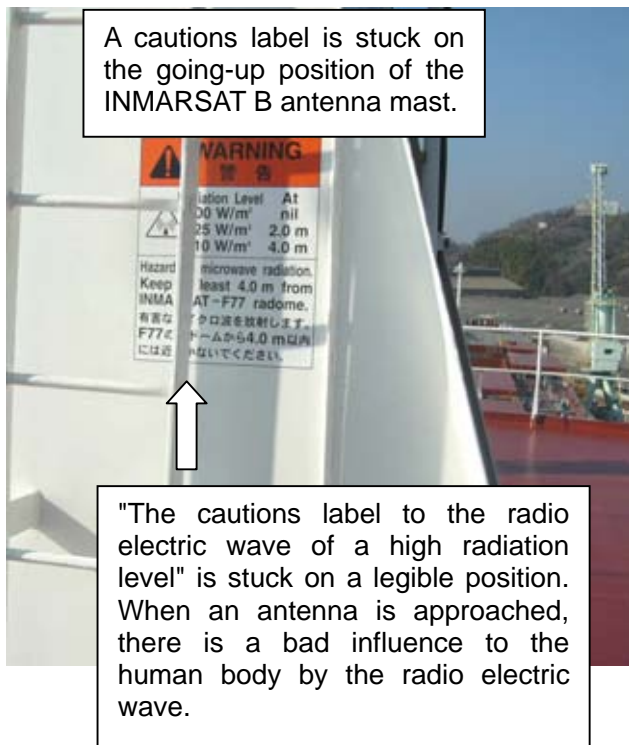

Fig. 5.4.4 Caution label

5.4.3 Mounting of BDE

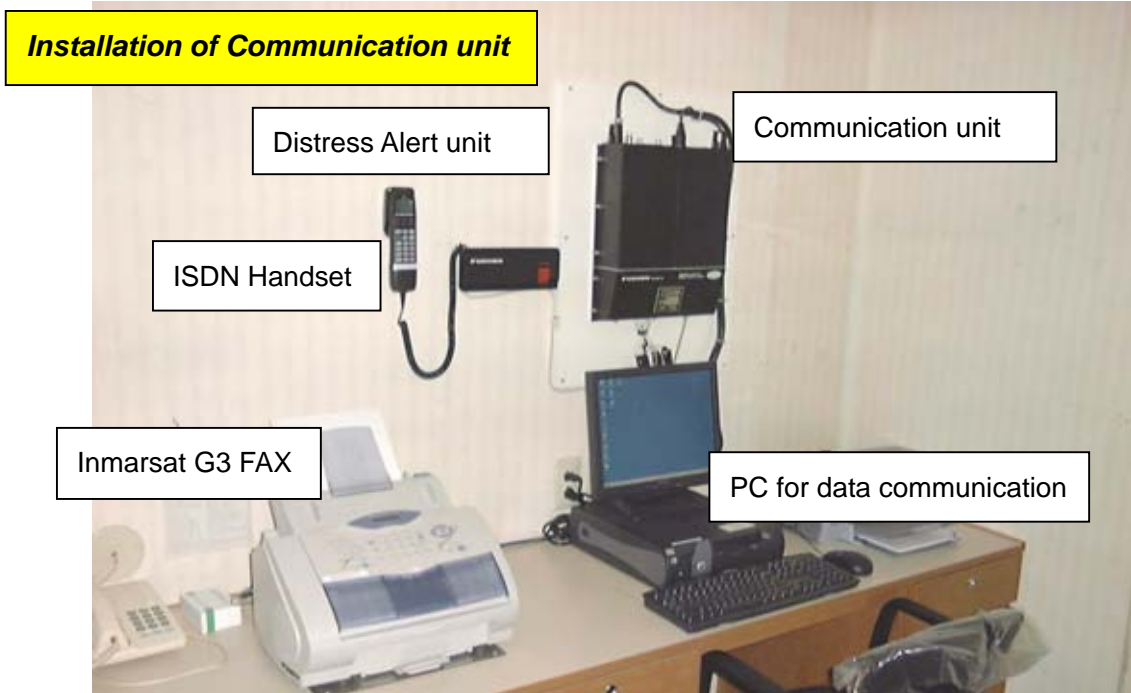

Fig. 5.4.5 Installation of BDE

5.4.4 Wiring of Communication unit

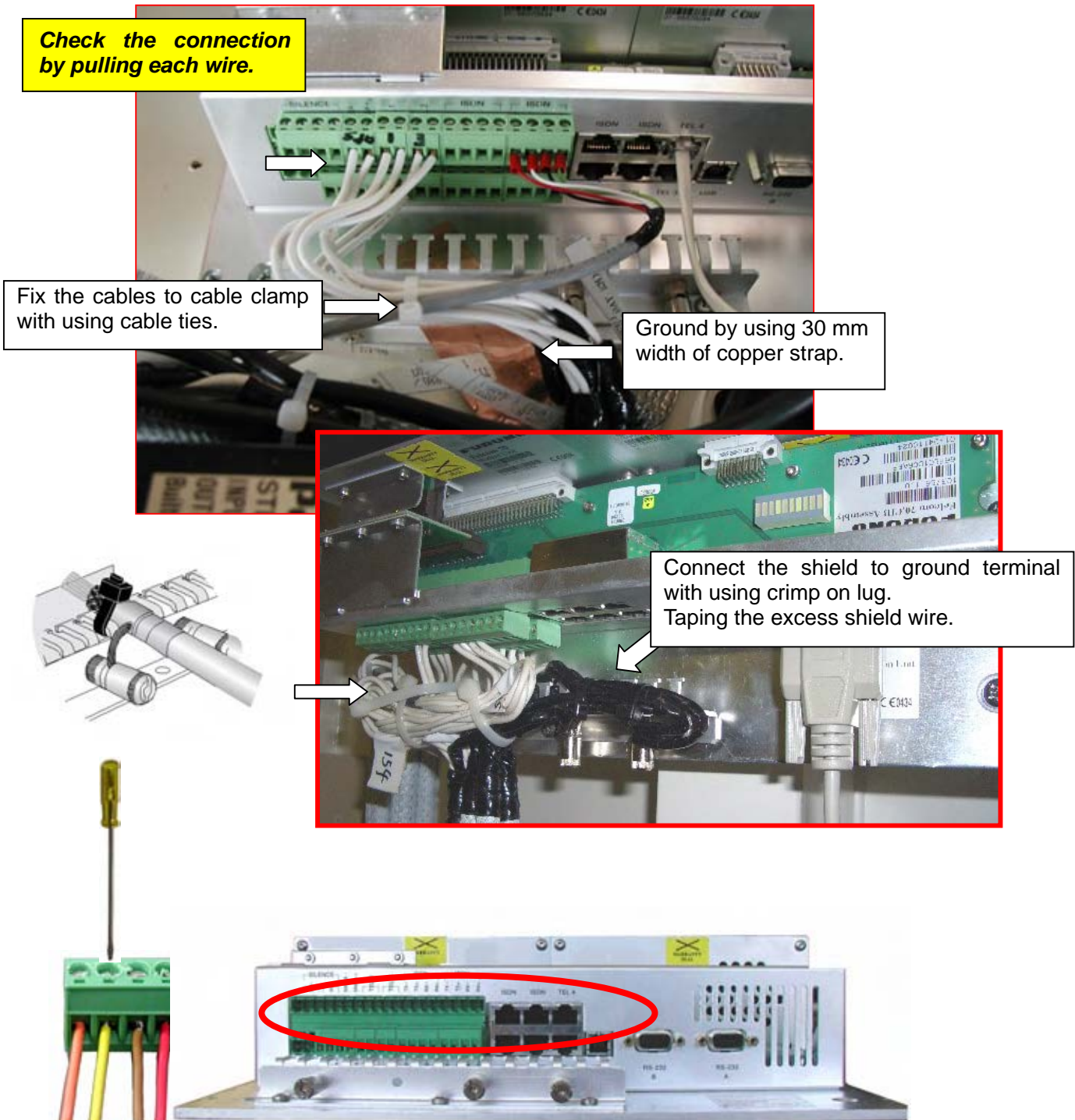

Fig. 5.4.6 Wiring of Communication unit

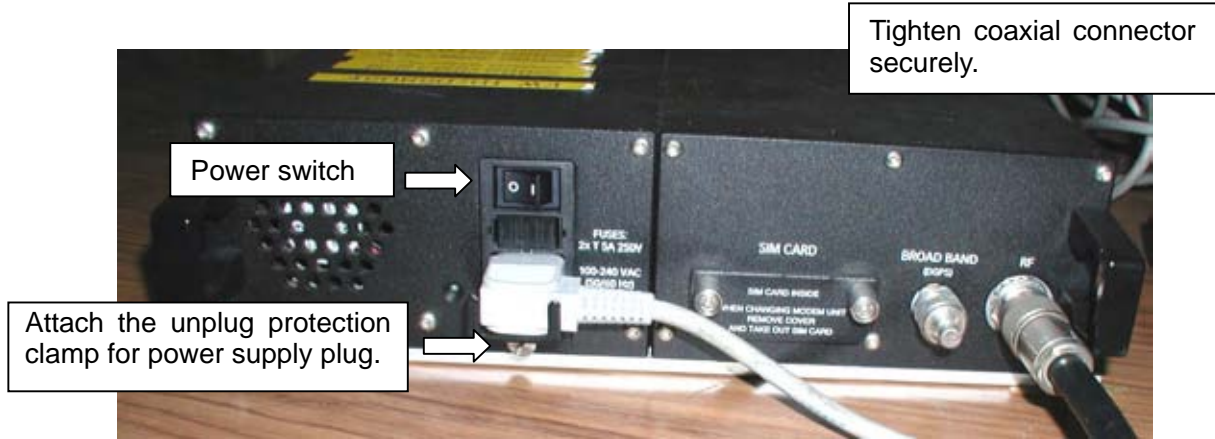
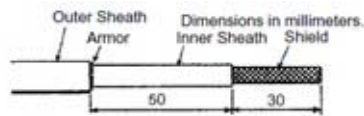
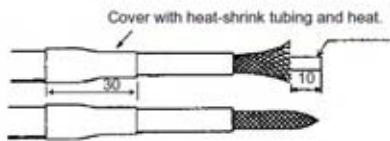

Fig. 5.4.7 Rear panel of Communication unit

Fabrication of N-P-8DFB



Remove outer sheath and armor by the dimensions shown left. Expose inner sheath and shield by the dimensions shown left.



Remove insulator and core by 10 mm.

Twist shield end.

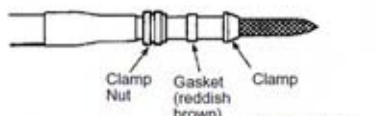

Slip on clamp nut, gasket and clamp as shown left.

Fold back shield over clamp and trim.

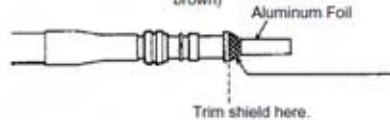

Cut aluminum foil at four places, 90 from one another.

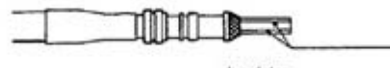

Fold back aluminum tape foil onto shield and trim.

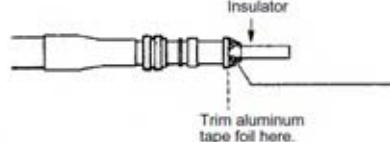

Expose the insulator by 1 mm. Expose the insulator by 5 mm.

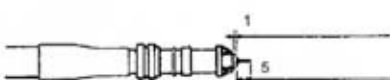

Slip the pin onto the conductor. Solder them together through the hole on the pin.

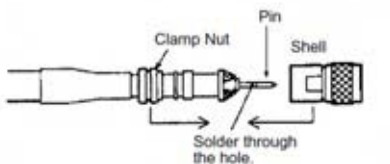

Insert the pin into the shell. Screw the clamp nut into the shell.

Tighten by turning the clamp nut. Do not tighten by turning the shell.

5.4.5 Wiring of Distress Alert unit

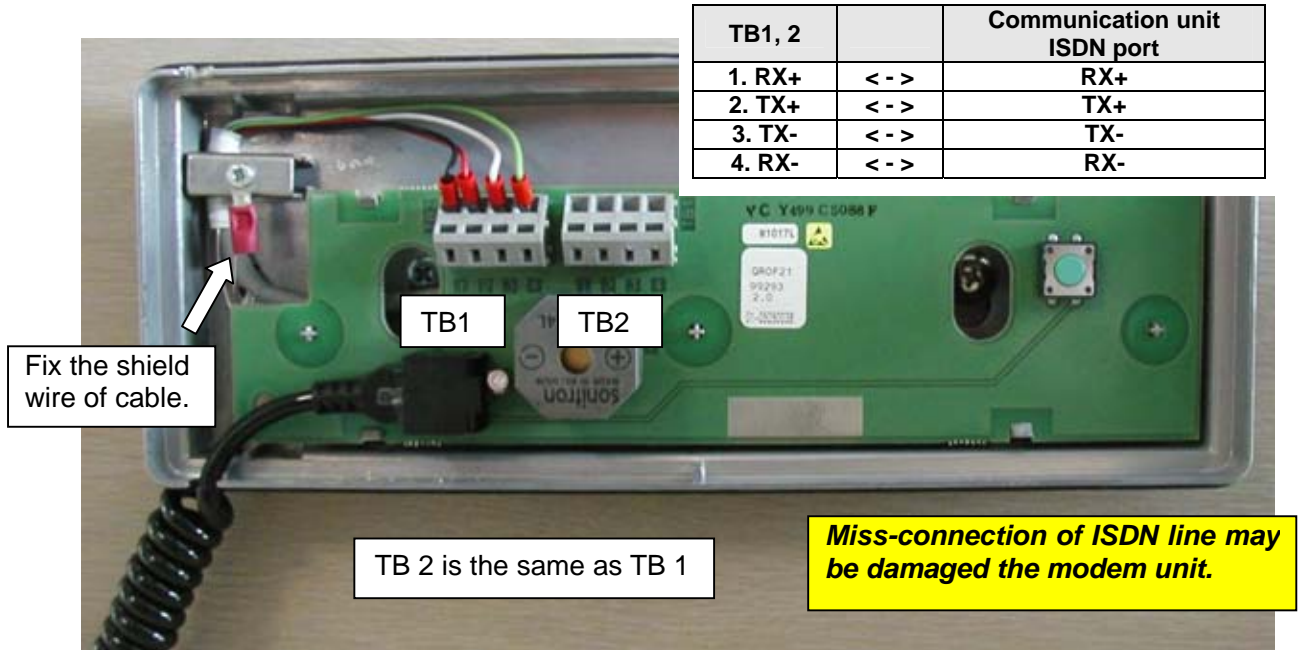

Fig. 5.4.8 Distress Alert unit

When connecting another Distress Alert unit or ISDN Wall Socket, make cable entrance of "8 mm hole" with a drill.

1. Remove the PC board from the distress alert unit before making a hole.
2. Make hole at the position "a", "b" or "c" in accordance with the cable run.
3. Smooth the inner and outer edge of hole.

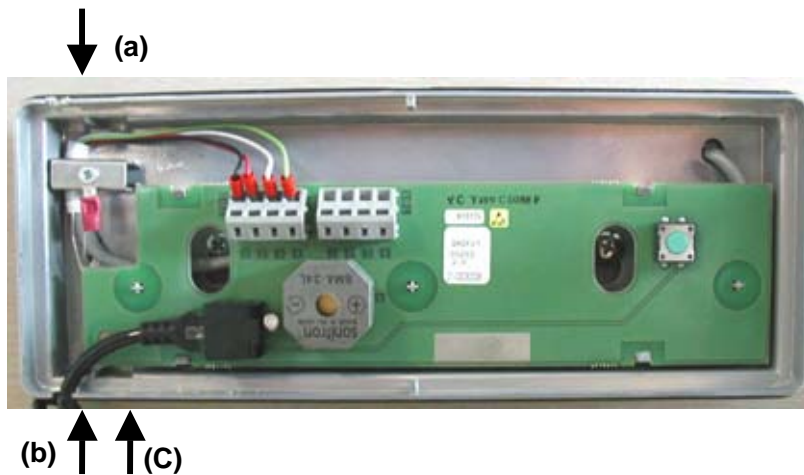

Fig. 5.4.9 Modified Distress Alert unit

5.4.6 Connection of ISDN devices

ISDN devices are connected to the ISDN outlet on the Communication unit either terminal blocks or RJ45 jacks.

The ISDN bus can be connected to one of the ISDN outlets. Maximum extension length is 100 m, min. 0.22 mm. In this case, the cable length connected to other outlets must be less than 10 m.

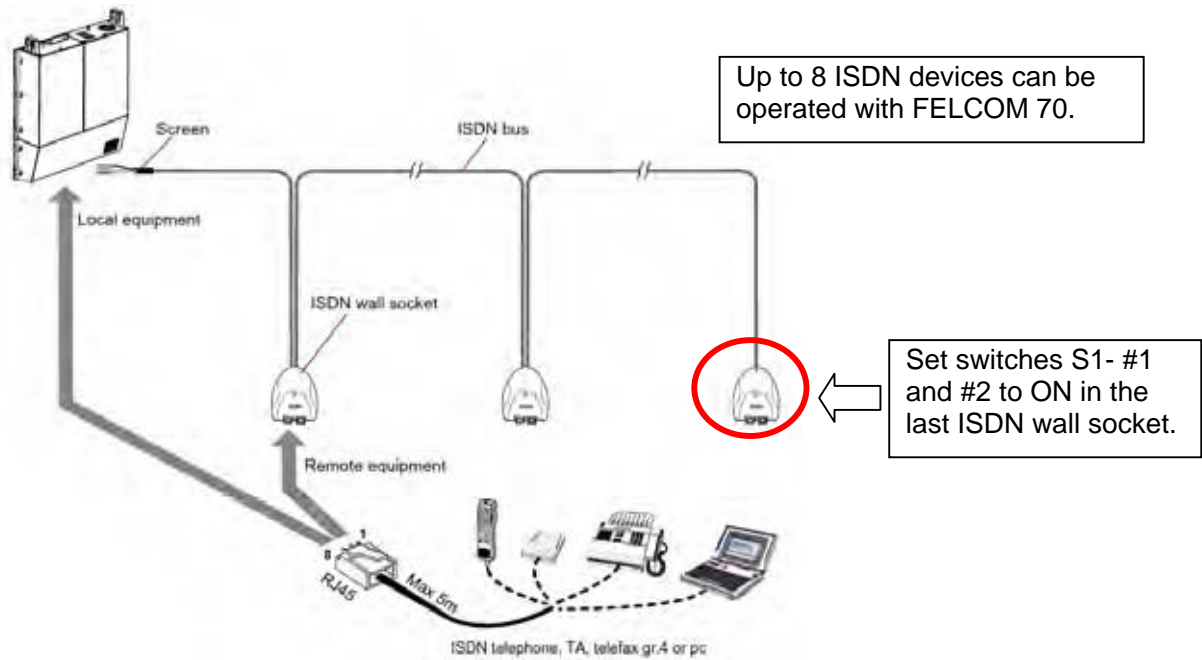

Fig. 5.4.10 Connection of ISDN equipments

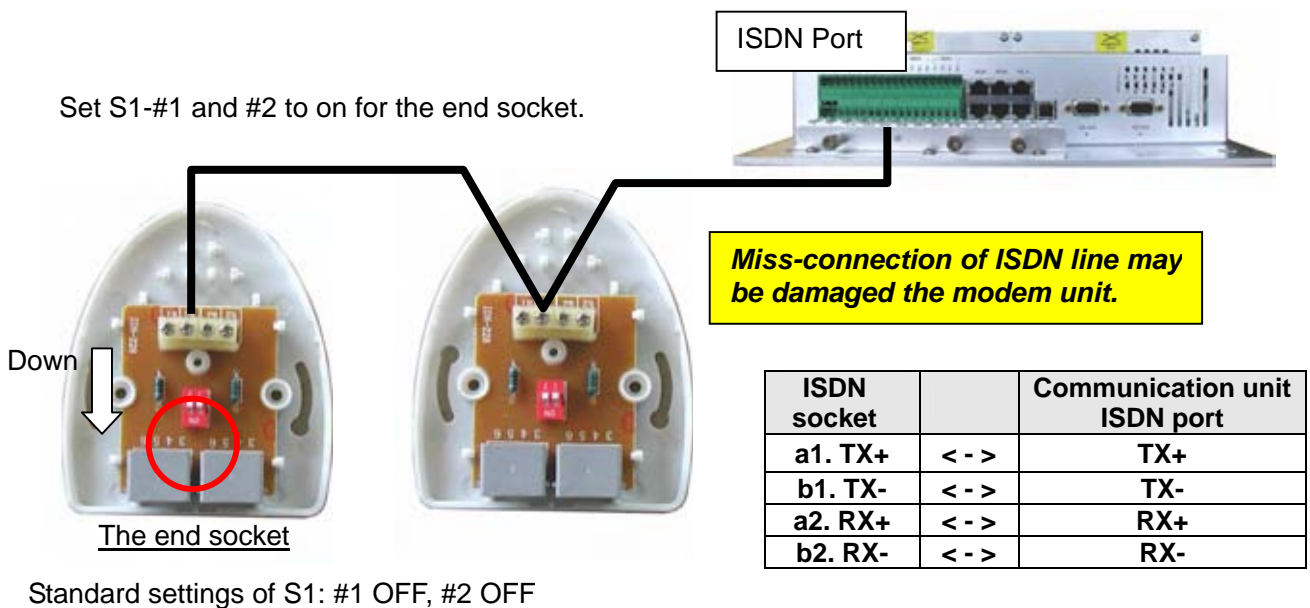

Fig. 5.4.11 Wiring in ISDN Wall Socket

5.4.7 Connection of Analogue Telephone/G3 FAX (option)

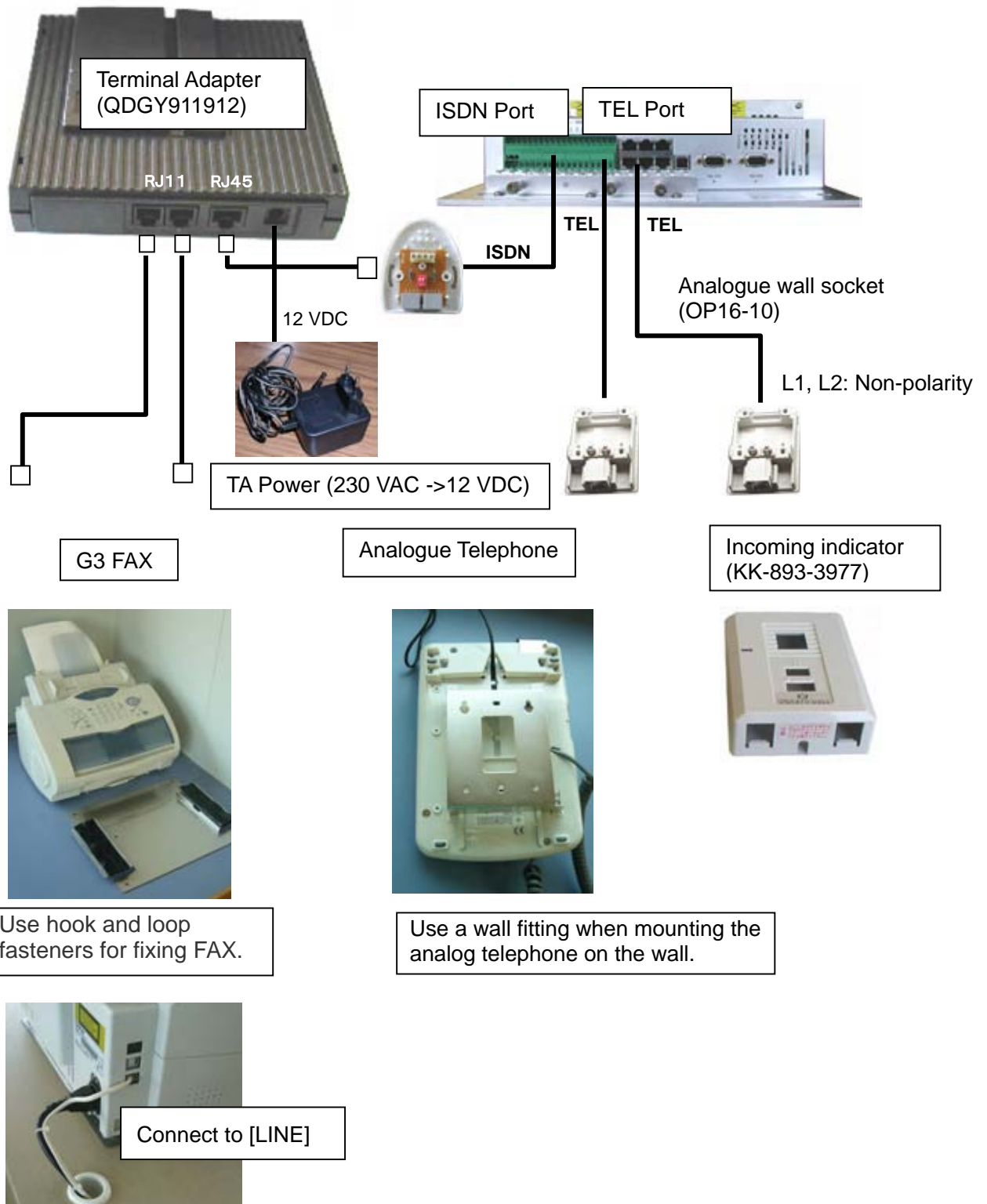

Fig. 5.4.12 Connection of Analogue devices

6.1 Installation of NAVTEX

6.1.1 Mounting of NAVTEX antenna

- * Fix antenna to antenna mast with hose clamp and mounting bracket securely.
- * Waterproof the junction part of coaxial cable with self-bounding tape and vinyl tape properly.
- * Loop excess coaxial cable having diameter over 20 cm to prevent damaging the center conductor.

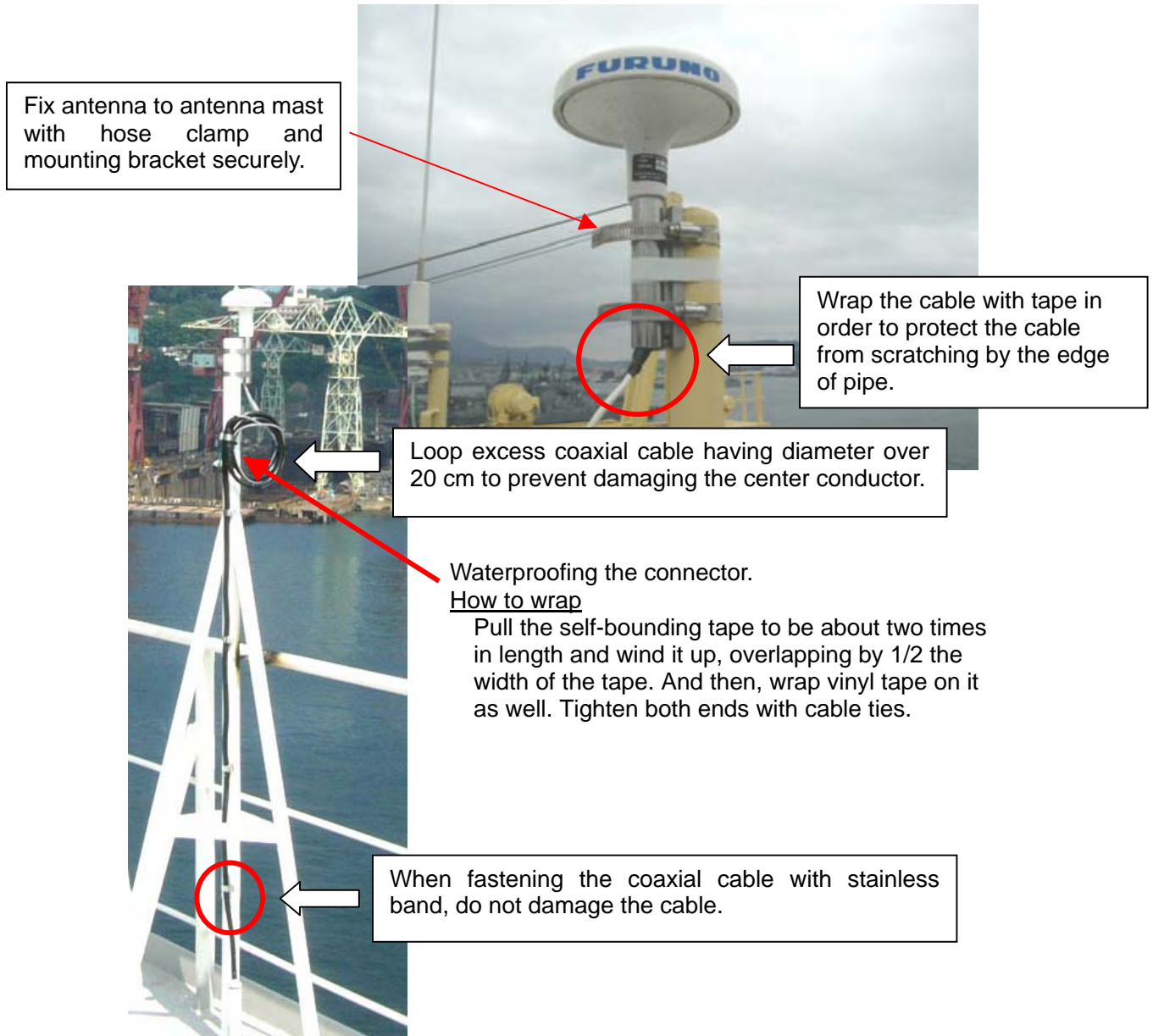

Fig. 6.1.1 Mounting of NAVTEX antenna

6.1.2 NAVTEX Display unit

Install the NAVTEX display unit in the wheelhouse.

NX-700A: Built-in printer type



Front view



Rear view

NX-700B: No printer type



Front view



Rear view

Fig. 6.1.2 NAVTEX display unit

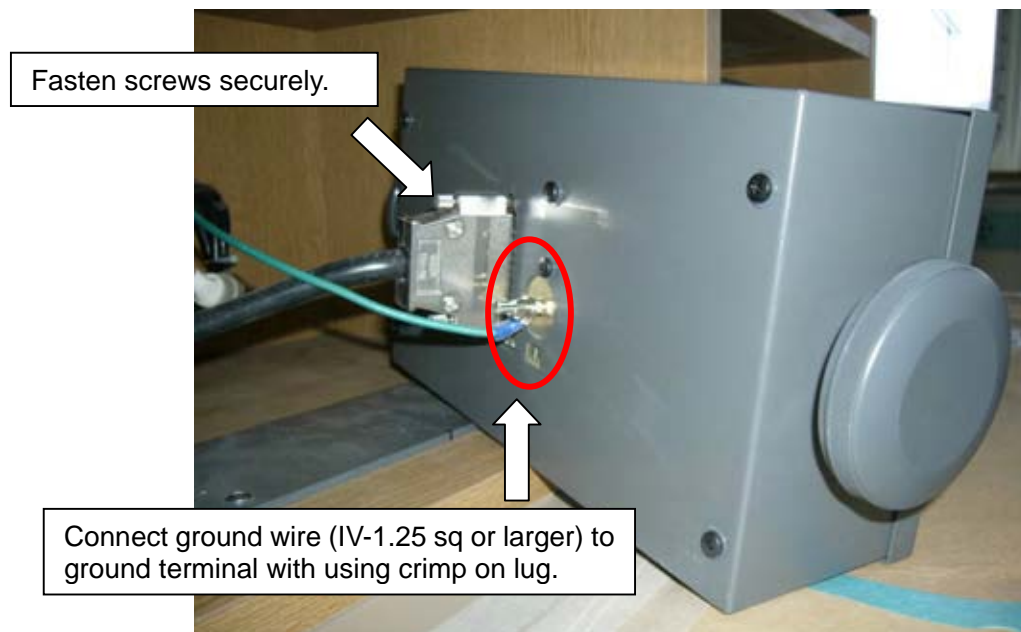

Fig. 6.1.3 Connection

6.1.3 NAVTEX Receiver unit

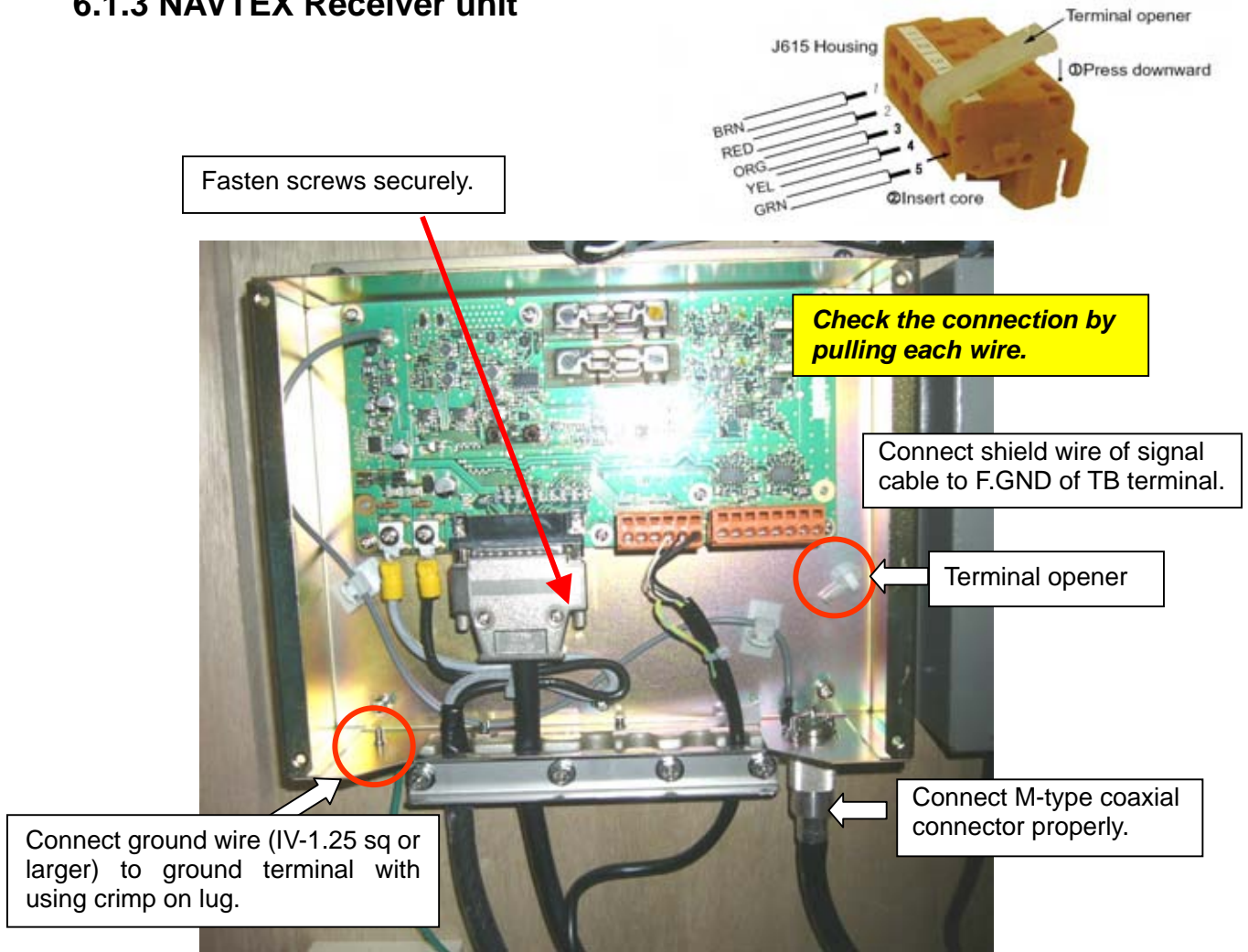

Fig. 6.1.4 Connection of the Receiver unit

Improper fabrication

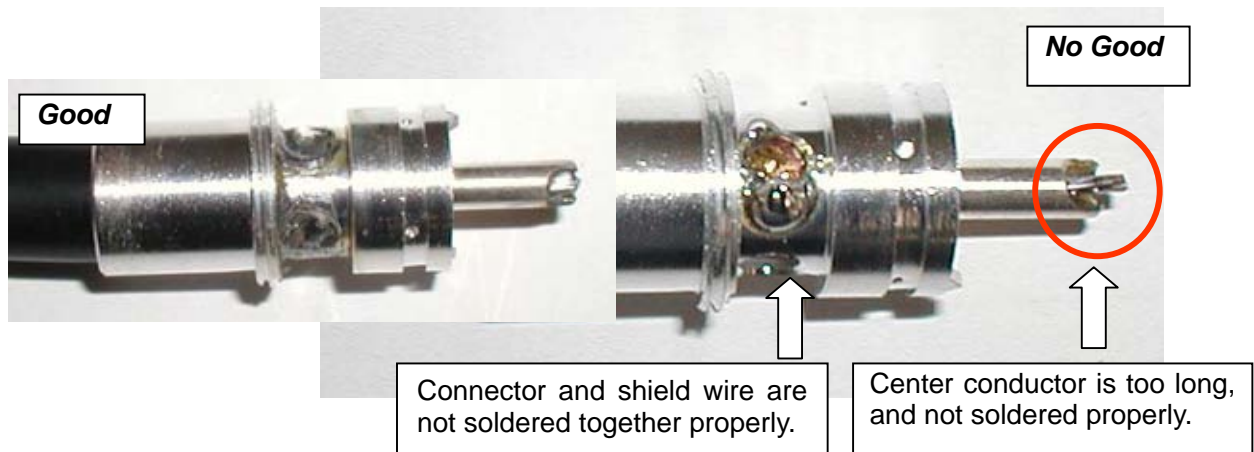

Fig. 6.1.5 Improper fabrication

6.2 Installation of FAX Receiver

6.2.1 Mounting of Antenna

- * Fix antenna to antenna mast with hose clamp and mounting bracket securely.
- * Waterproof the junction part of coaxial cable with self-bounding tape and vinyl tape properly.
- * Loop excess coaxial cable having diameter over 20 cm to prevent damaging the center conductor.
- * Ground the antenna having whip antenna (FAX-5) properly to improve the S/N ratio.

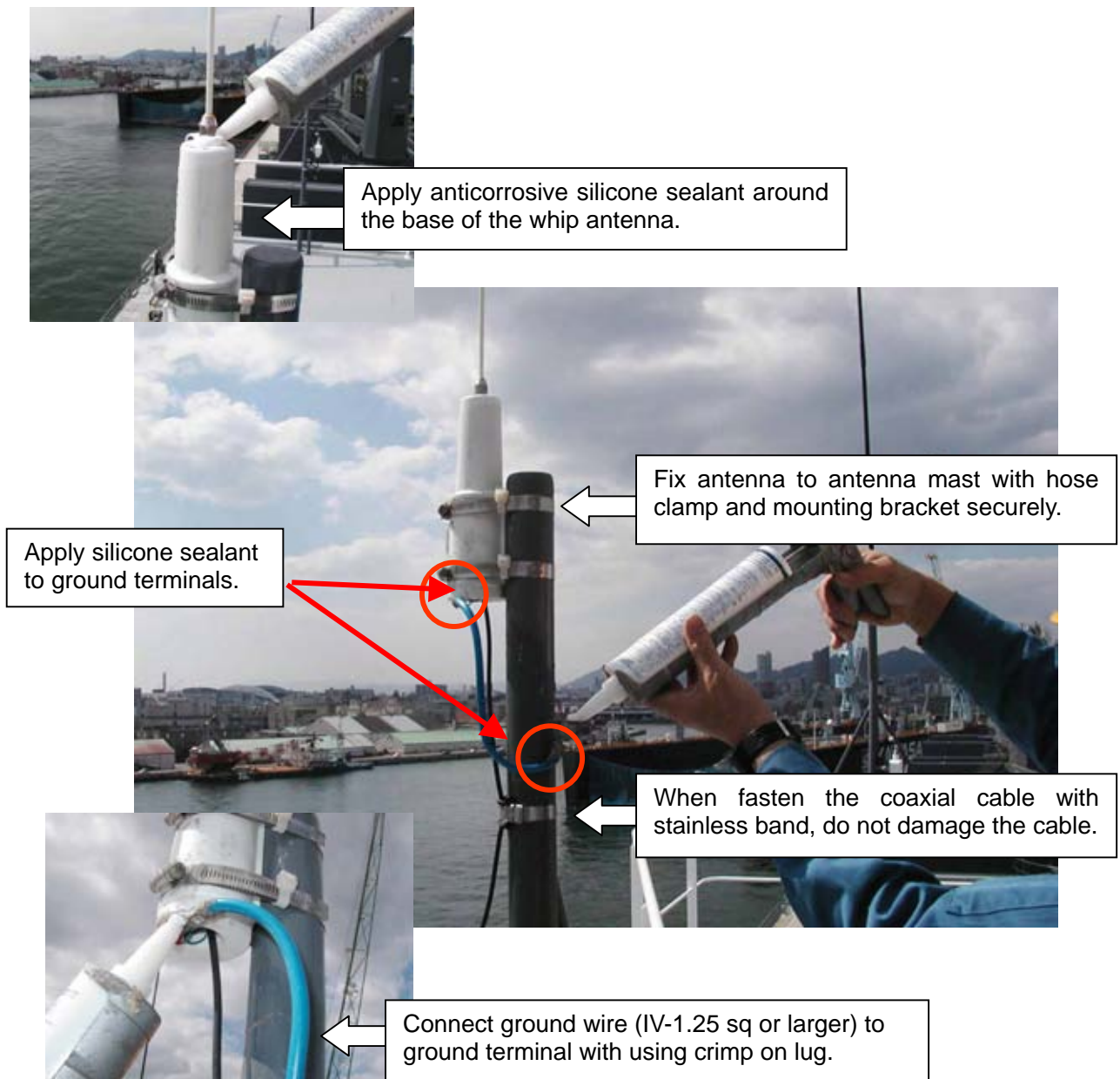

Fig. 6.2.1 Mounting of FAX antenna-1



Loop excess coaxial cable having diameter over 20 cm to prevent damages of the center conductor.

Waterproofing the connector.

How to wrap

Pull the self-bounding tape to be about two times in length and wind it up, overlapping by 1/2 the width of the tape. And then, wrap vinyl tape on it as well. Tighten both ends with cable ties.

Fig. 6.2.2 Mounting of FAX antenna-2

6.2.2 Installation of FAX Receiver

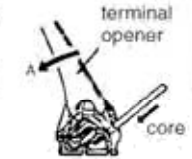

Fig. 6.2.3 Mounting of FAX receiver

1. Remove the end of each core by 5-6 mm. 
2. As shown in the figure, set the opener in a terminal. While pulling the opener downward, insert the core. 
3. Release the opener. Tug on the core to confirm it is inserted properly.

Check the connection by pulling each wire.

Make connection without fault, and bind wires with cable ties.

Connect ground wire (IV-1.25 sq or bigger) to ground terminal with using crimp on lug.

Fig. 6.2.4 Grounding and wiring of FAX-215 receiver

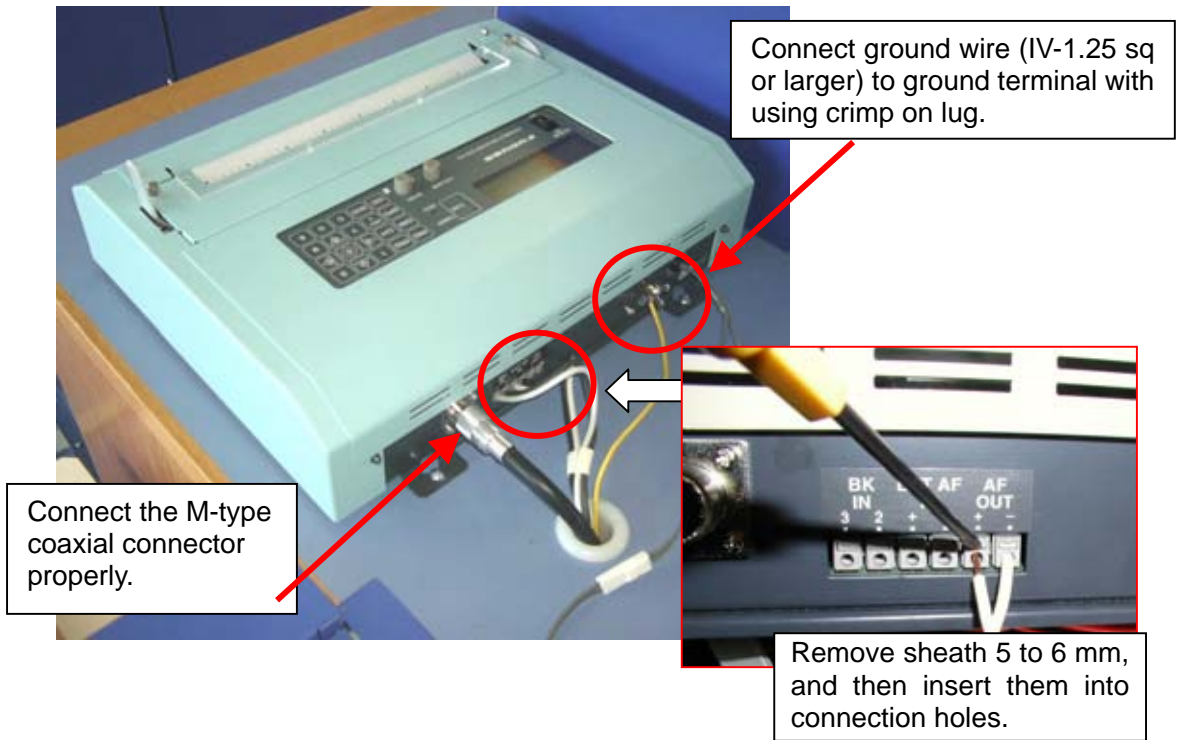

Fig. 6.2.5 Connection of FAX-410

Improper fabrication

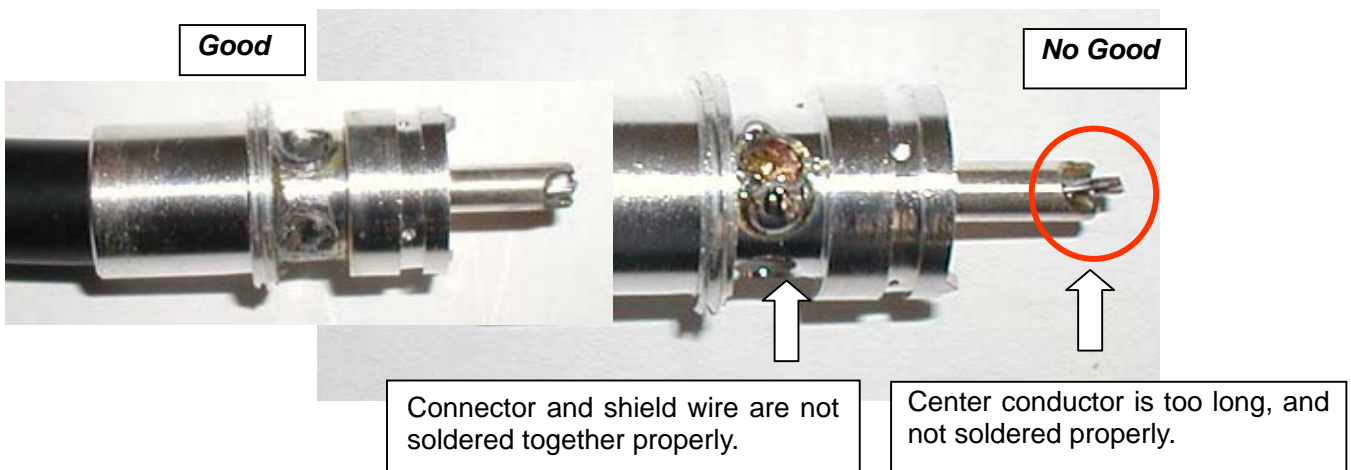

Fig. 6.2.6 Improper fabrication

7.1 Mounting of GPS antenna

- * Fix antenna to antenna mast with hose clamp and mounting bracket securely.
- * Waterproof the junction part of coaxial cable with self-bonding tape and vinyl tape properly.
- * Loop excess coaxial cable having diameter over 20 cm to prevent damaging the center conductor.
- * Ground the antenna unit with a whip antenna (GPA-018/018S) properly to improve the S/N ratio.

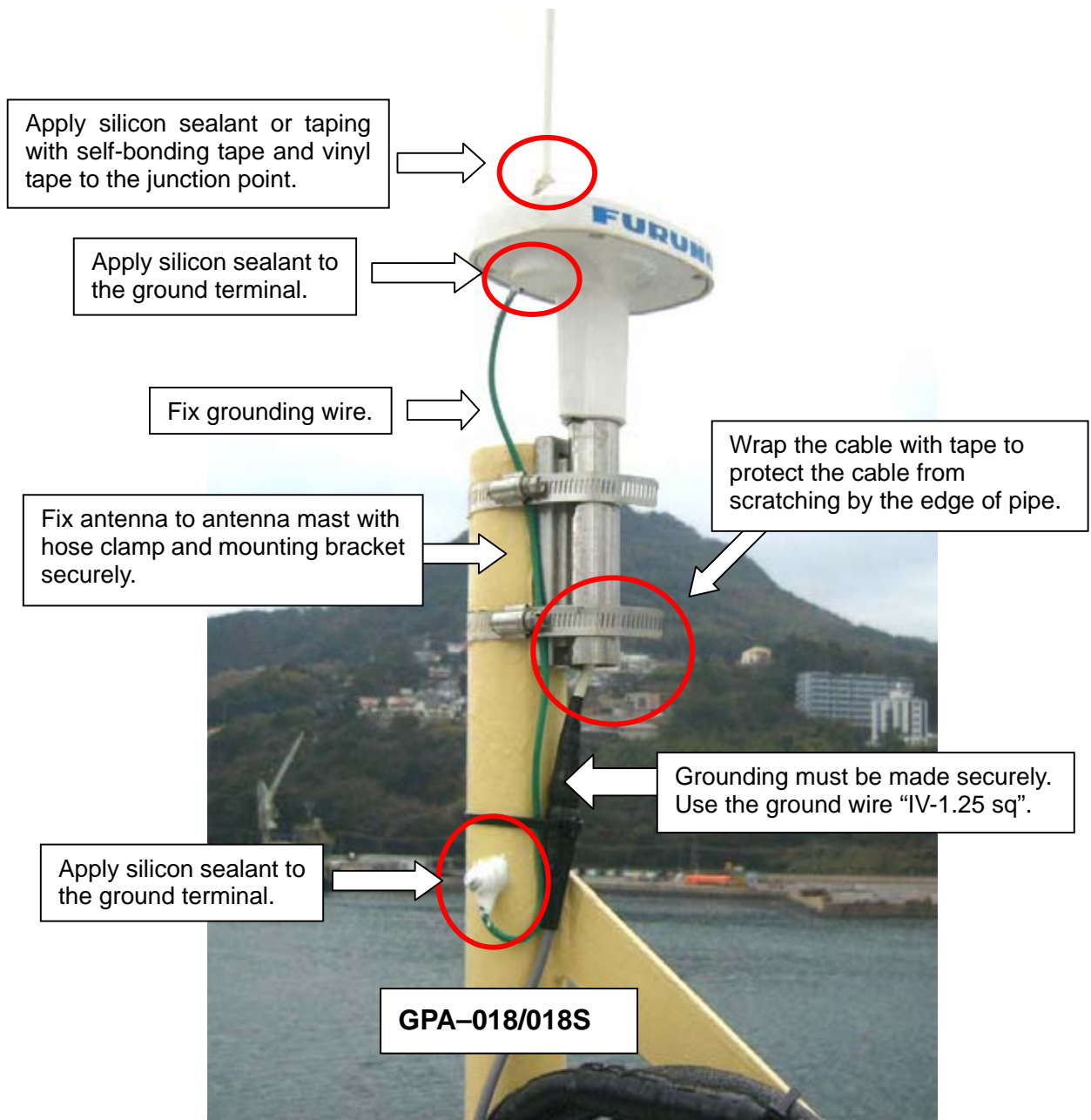

Fig. 7.1.1 Mounting of GPS antenna-1



Loop excess coaxial cable having diameter over 20 cm to prevent damages the center conductor.

Waterproofing the connectors.

How to wrap

Pull the self-bonding tape to be about two times in length and wind it up, overlapping by 1/2 the width of the tape. And then, wrap vinyl tape on it as well. Tighten both ends with cable ties.

When fastening the coaxial cable with stainless band, do not damage the cable.

Fig. 7.1.2 Mounting of GPS Antenna-2

Fabrication of N-P-8DFB

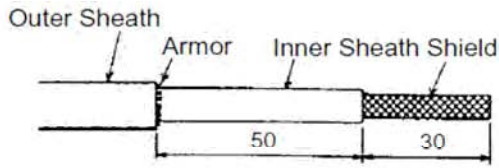

Remove outer sheath and armor by the dimensions shown left.
Expose inner sheath and shield by the dimensions shown left.

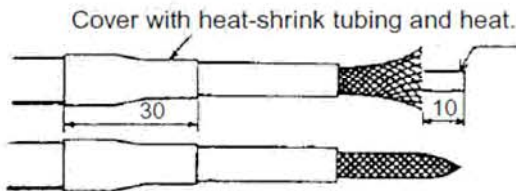

Cut off insulator and core by 10mm.

Twist shield end.

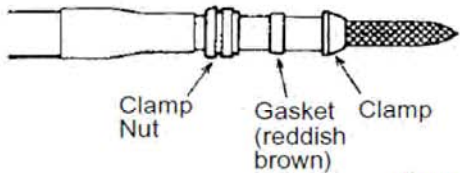

Clip on clamp nut, gasket and clamp as shown left.

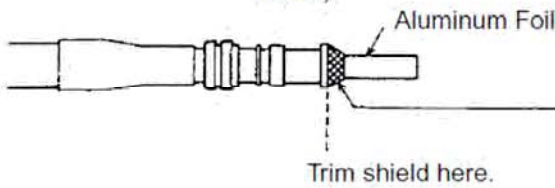

Fold back shield over clamp and trim.

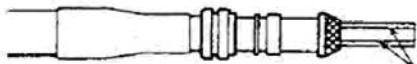

Cut aluminum foil at four places, 90° from one another.

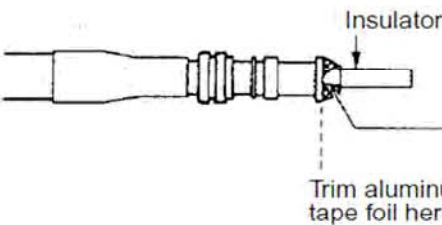

Fold back aluminum foil onto shield and trim.



Expose the insulator by 1mm.

Expose the core by 5mm.

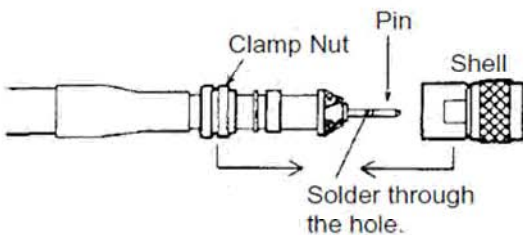

Slip the pin onto the conductor. Solder them together through the hole on the pin.

Insert the pin into the shell. Screw the clamp nut into the shell.
(Tighten by turning the clamp nut. Do not tighten by turning the shell.)

Never turn the shell.

7.2 Mounting of GPS Display unit

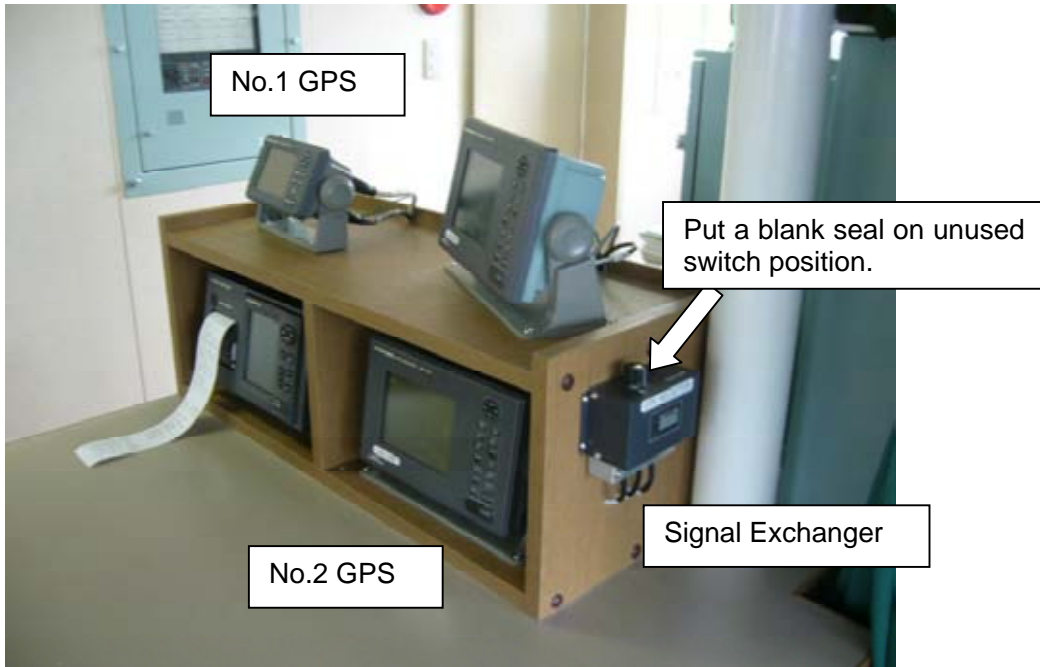

Fig. 7.2.1 Mounting of GPS display unit

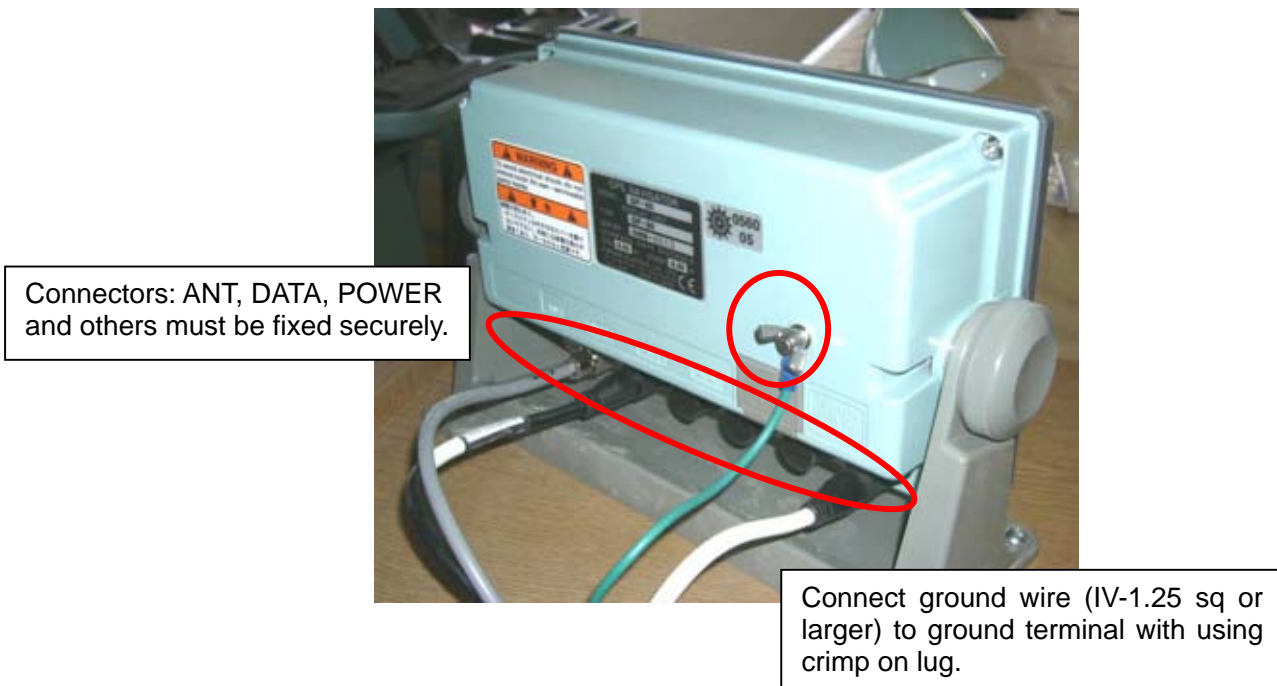
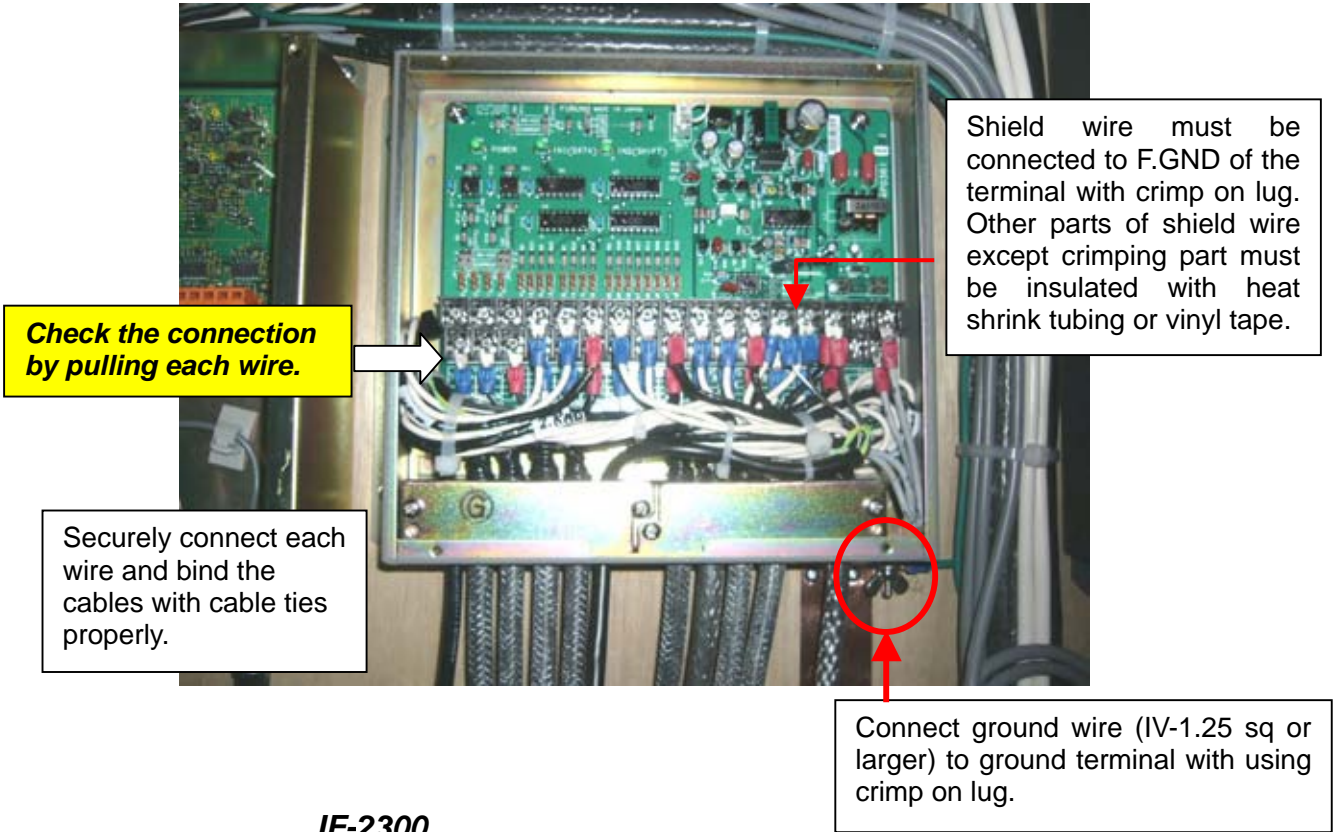

Fig. 7.2.2 Connections of GPS

7.3 Mounting of GPS Multi-Distributor

MD-550



IF-2300

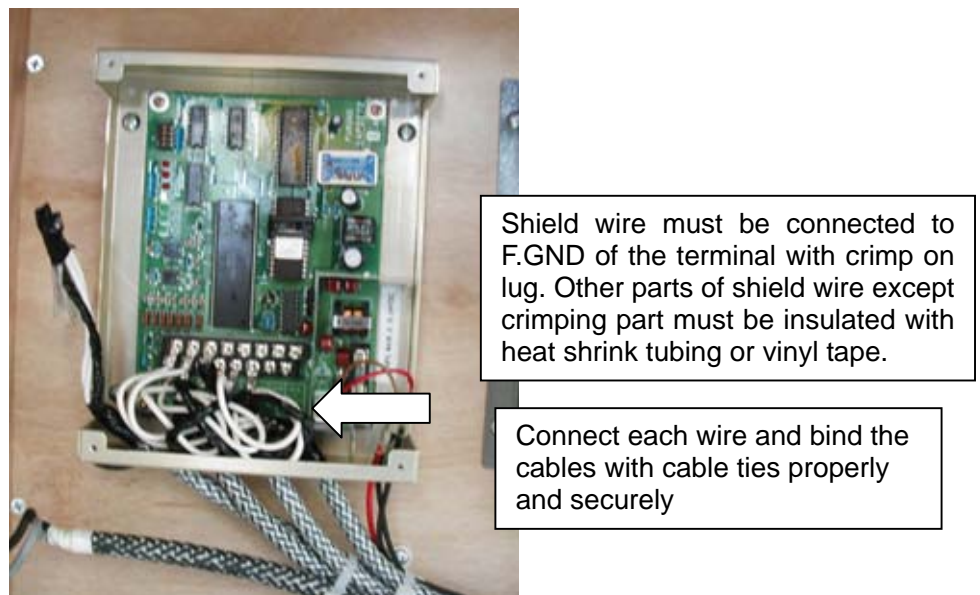

Fig. 7.3.1 Installation of IF-2300

8.1 Mounting of AIS antenna

- * Fix antenna with antenna fixing bracket securely.
- * Waterproof the junction part of coaxial cable with self-bonding tape and vinyl tape properly.
- * Loop excess coaxial cable having diameter over 20 cm to prevent damages of the center conductor.

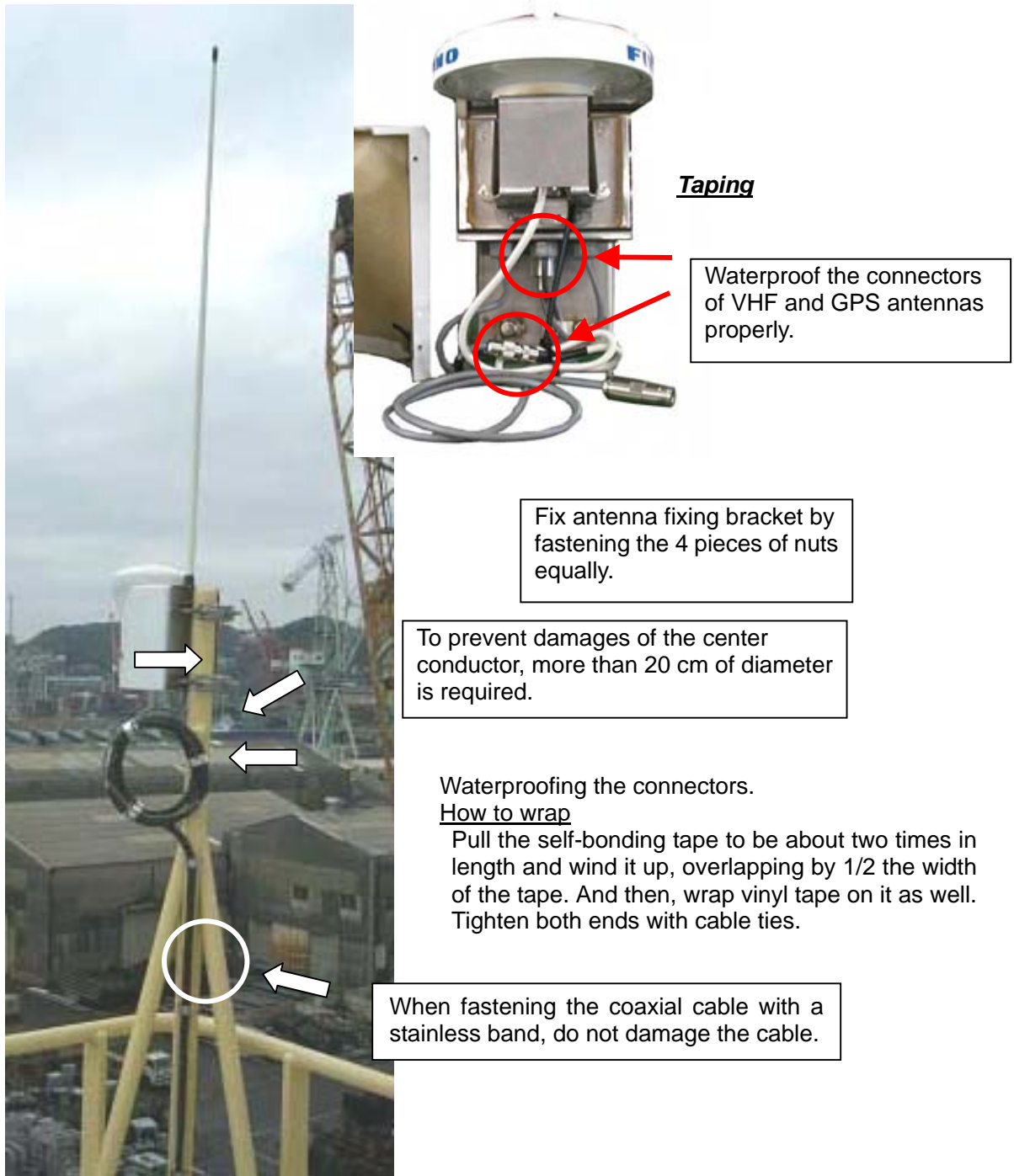

Fig. 8.1.1 Mounting of AIS antenna

8.2 Mounting of AIS Display and Transponder units

8.2.1 AIS Display unit : FA-1502

The AIS display unit is installed at where the ship's officer controls the ship, where the ship's officer can operate AIS easily, or at the coning position. For example, beside of radar display unit, ECDIS display unit or center of the coning position.



Fig. 8.2.1 AIS Display unit



Fig. 8.2.2 Connection of AIS Display unit

8.2.2 AIS Transponder unit: FA-1501



Connect ground wire (IV-1.25 sq or larger) to ground terminal using with a crimp on lug.

Fig. 8.2.3 AIS Transponder unit

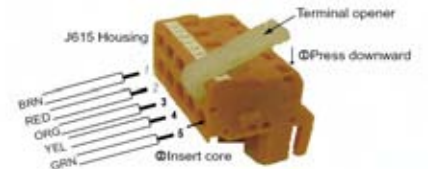

Terminal opener

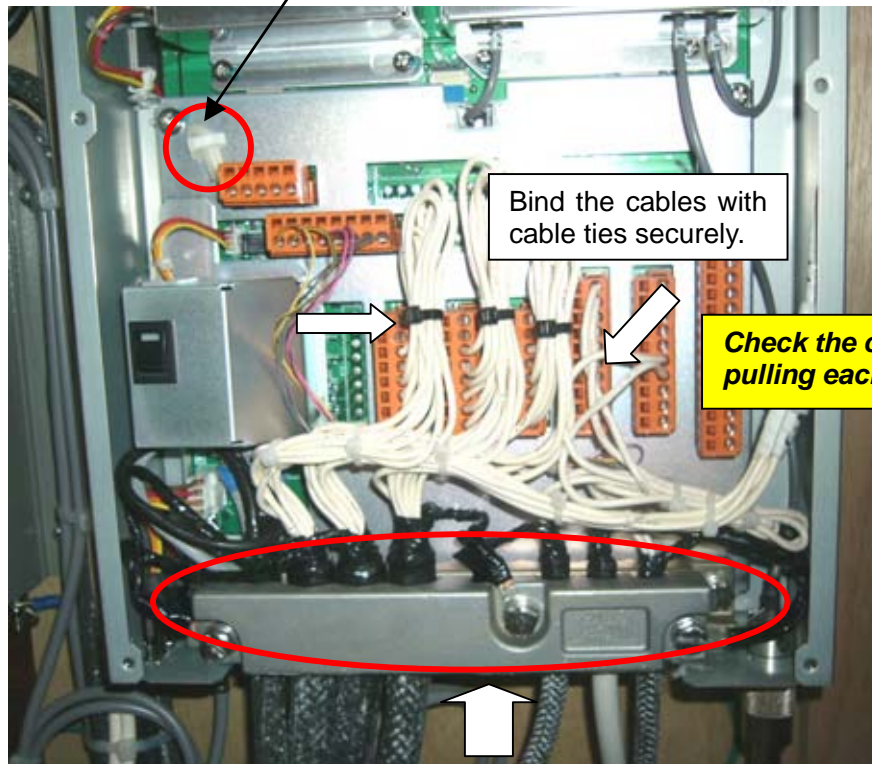

Bind the cables with cable ties securely.

Check the connection by pulling each cable.

Connect shield wire to cable crimp using with a crimp on lug. Other parts of shield wire except for crimping part must be insulated with heat shrink tubing or vinyl tape.

Fig. 8.2.4 Wiring in the AIS transponder unit

8.2.3 AIS Power Supply: PR-240-CE

AIS and connected sensors (e.g. GPS) should be connected ship's main source and other source, such as emergency source or reserve source.

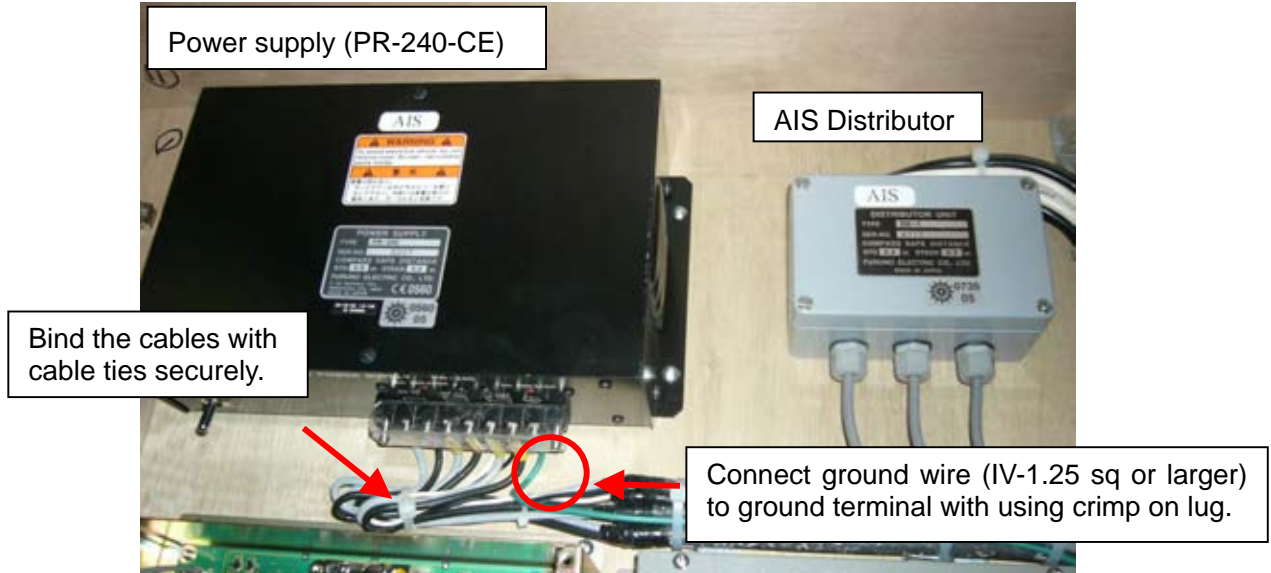

Fig. 8.2.5 Wiring of Power supply unit

PR-240-CE has already set to a 200 - 230 VAC in the factory. If the AC input power source is 100 VAC - 115 VAC, change the tap connection and terminal board connection as below. Attach label supplied as accessories to the check mark on the front panel according to the AC input power source.

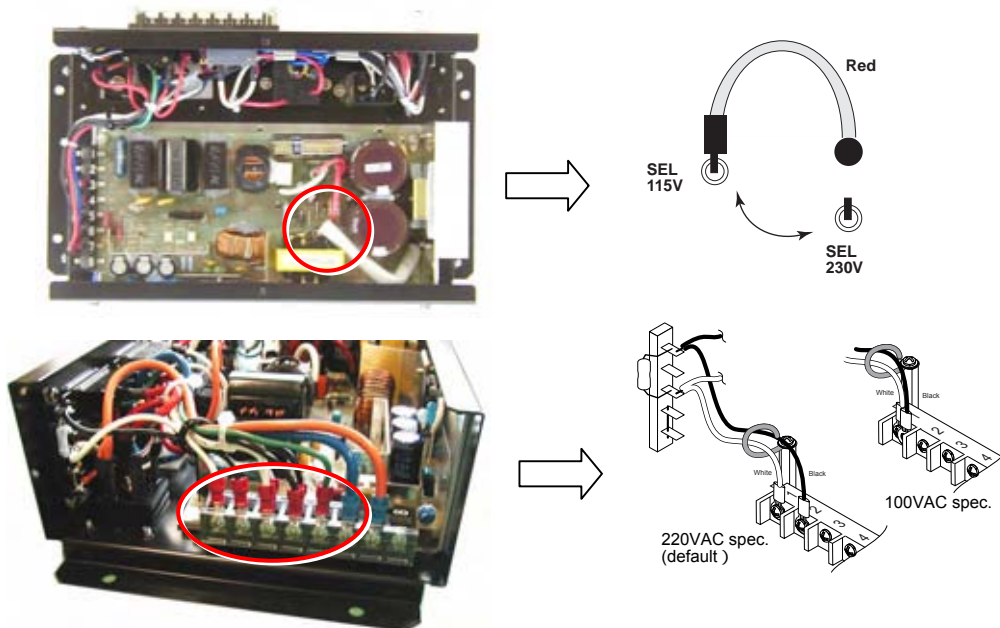

Fig. 8.2.6 Changing Ship's Mains Specifications of PR-240-CE

8.2.4 Pilot Plug

All ships who navigate the Panama canal, the Saint Lawrence river and enter a port of the USA are required the pilot plug for the AIS. And also required AC plug for the PC at near the pilot plug.

The pilot plug is installed at where the pilot commands the navigation, such as coning position. Pilot Plug should apply [AIS Pilot Plug] label, and the AC plug should apply the label of [Receptacle for Pilot PC] too.

Receptacle should be USA Standard (NMEA 5-15R) 120V AC triple plug.

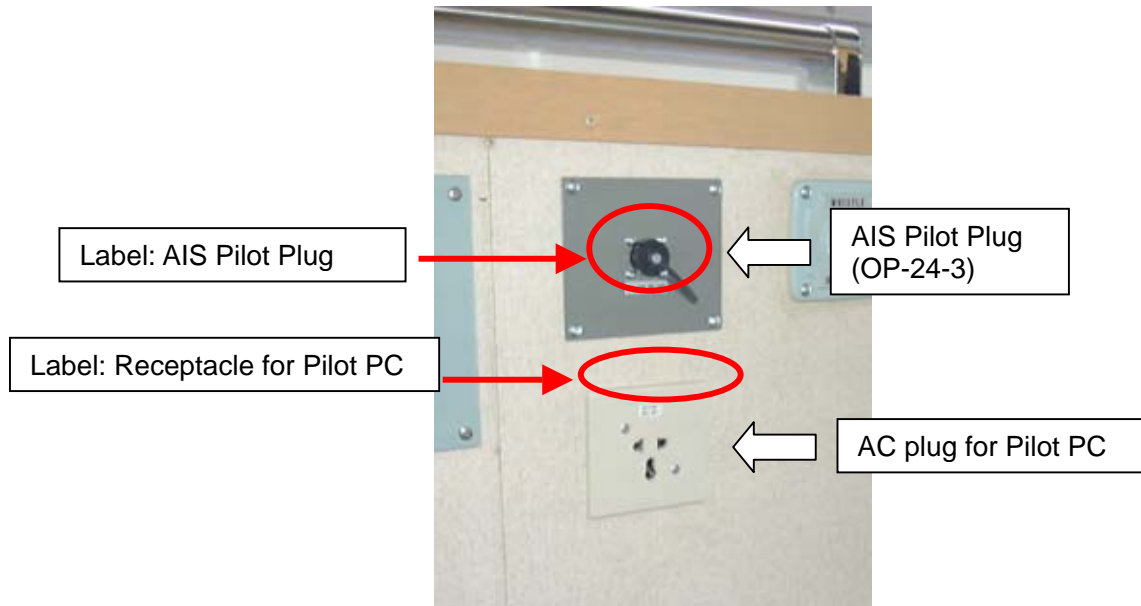
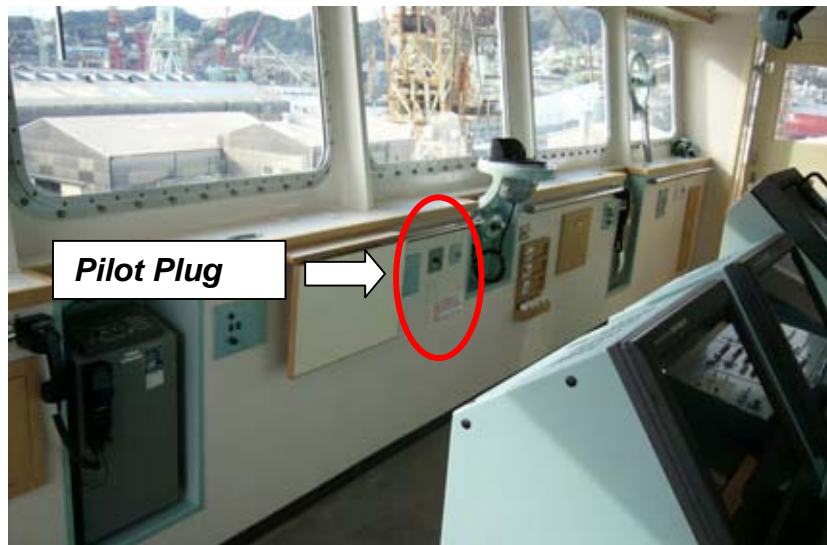

Fig. 8.2.7 Mounting of Pilot Plug

9.1 VR-5000: Installation of Data Collecting unit (DCU)

9.1.1 Mounting of DCU

The DCU is fixed by using 4 holes in the bottom plate (shipyard supplied; welding to hull) onto the supplied shock absorber with M10 bolts (x 4) as follows.

Fix the shock absorber onto the DCU mounting base arranged by the shipyard with four M10 bolts, put the cover over the shock absorber, fix the cover with supplied screws, and then fix the DCU to the shock absorber.

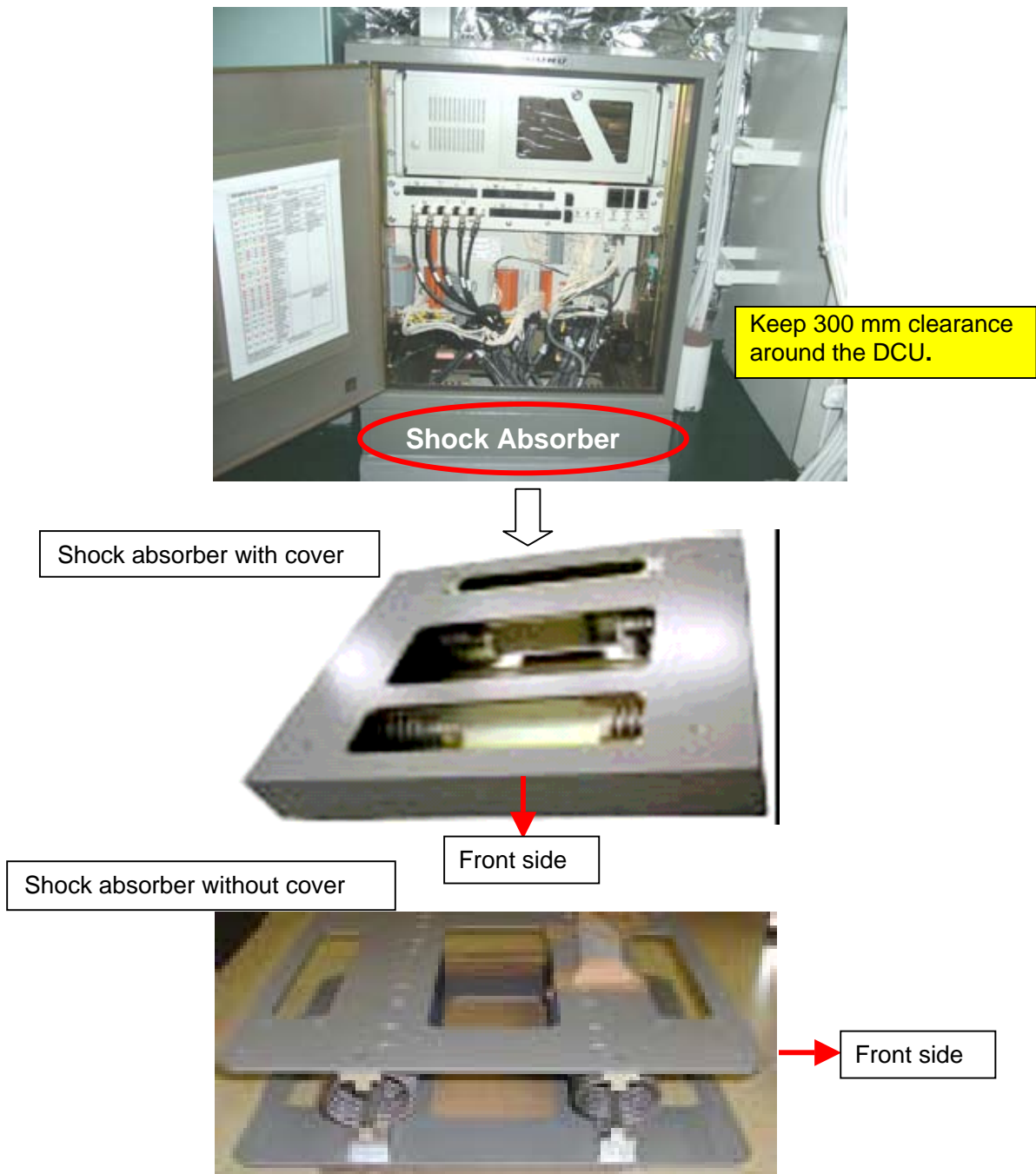

Fig. 9.1.1 Mounting of DCU

Wide cable entrance of cover must be front side of the DCU.
If the direction is inverted, because the balancer fixed to shock absorber does not work properly.

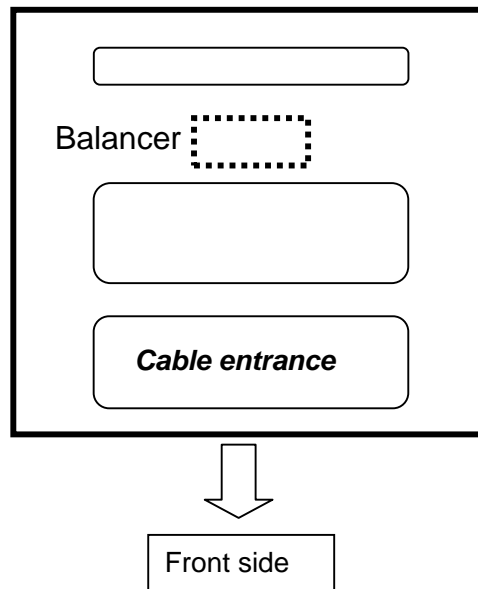
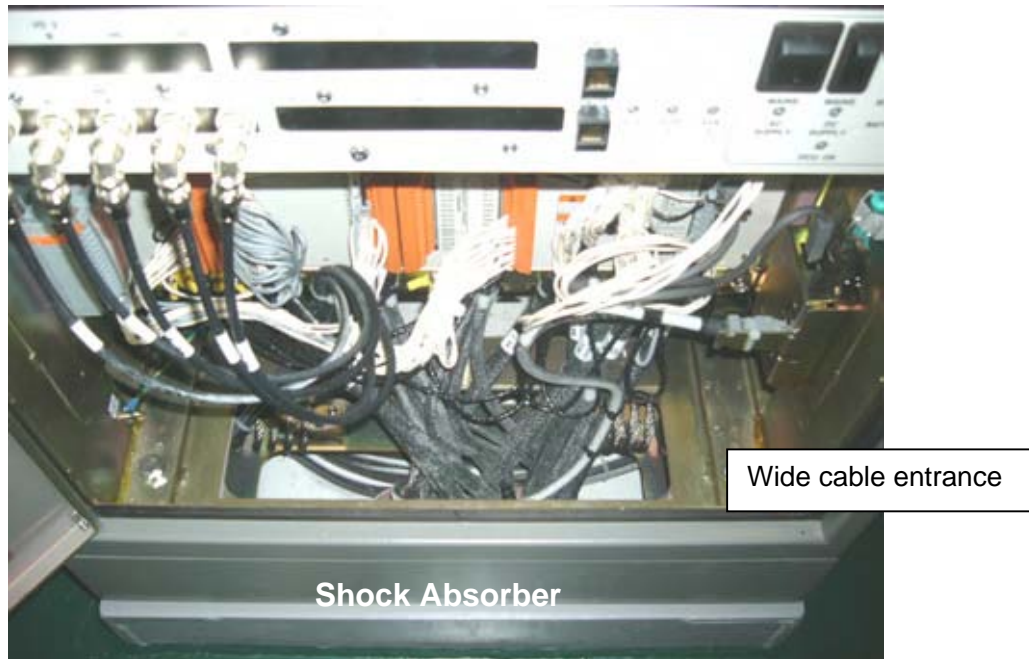

Fig. 9.1.2 Mounting of Shock Absorber

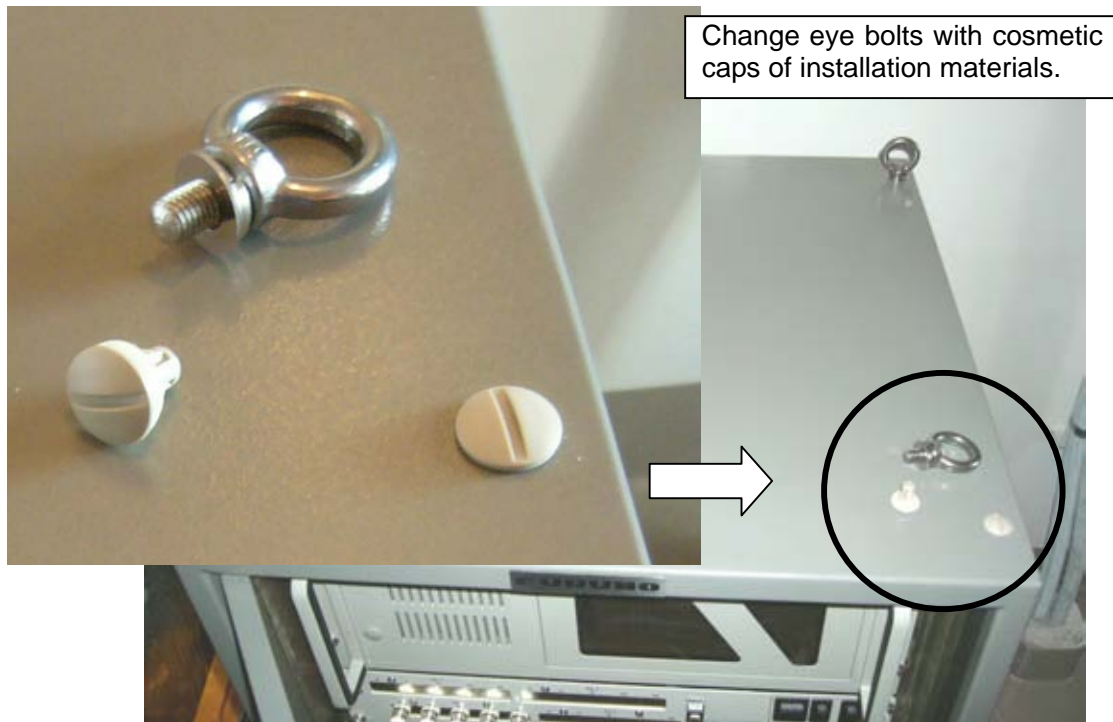

Fig. 9.1.3 Changing eye bolts with cosmetic caps

Note:

The DCU (data correcting unit) has anti-vibration system. If service space around the DCU is blocked, anti-vibration system does not work properly, and it causes the damage of the hard-disc or PC board of the DCU.

9.1.2 Wiring of DCU

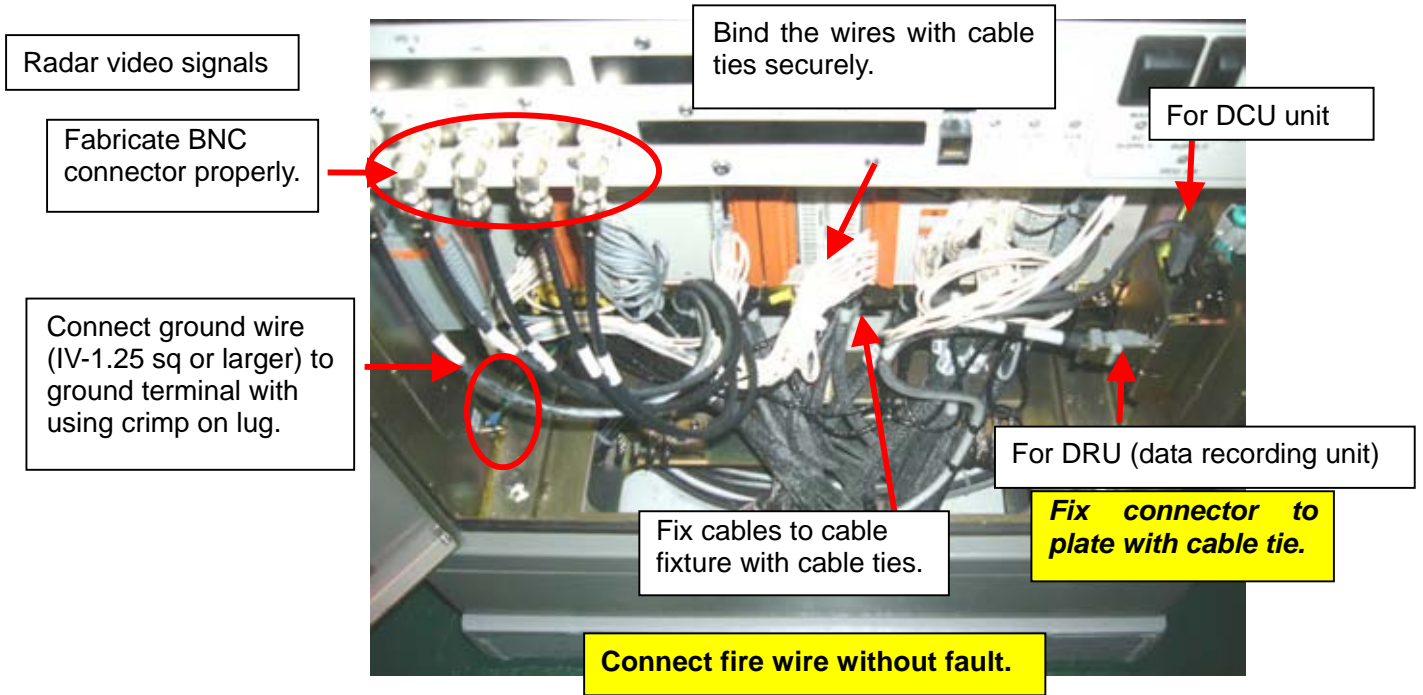

Fig. 9.1.4 Wiring of DCU-1

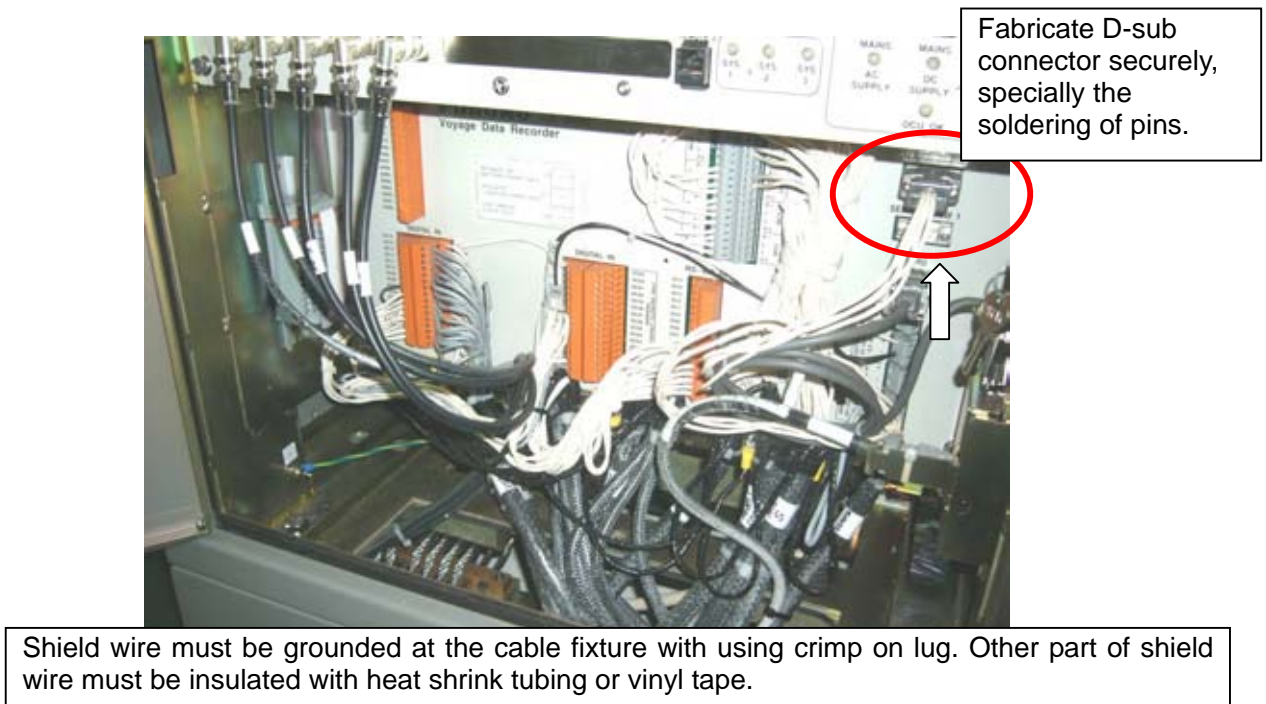
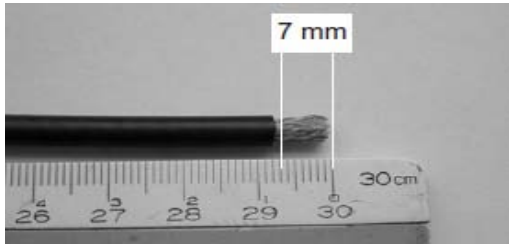
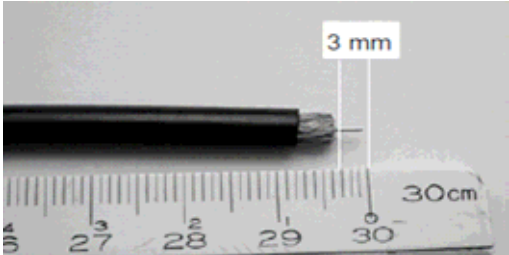

Fig. 9.1.5 Wiring of DCU-2

Fabrication of BNC connector



1. Cut off a cable jacket only 7 mm.
Don't damage the insulator in this time.



2. Strip shield and insulator by 3 mm.



3. Slip clamping nut, washer and gasket to the cable. Insert clamp to cable and fold back shield.

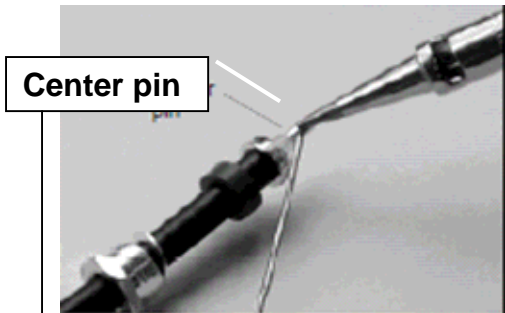

4. Put solder on core thin slightly.

5. Insert center pin to core and solder through pin hole.

“Do not melt the insulator by heating.”

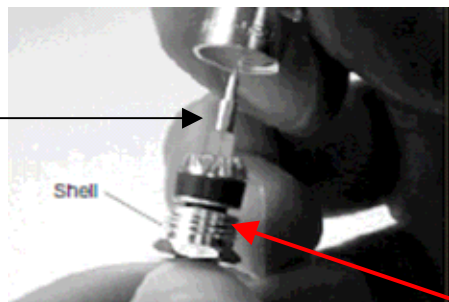

6. Screw the shell into cable.

Do not screw connector housing otherwise the core may be damaged.

Shell



9.2 VR-5000: Installation of Remote Alarm Panel and MIC

9.2.1 Remote alarm panel

Install the Remote alarm panel in the wheelhouse.

Example: Remote Alarm Panel installed on the switch panel



Fig. 9.2.1 Mounting of Remote Alarm Panel

9.2.2 Mounting of Bridge Microphone

Microphones are installed for recording all sound in the bridge. A maximum of 6 microphones can be connected to DRL.

For example:

It should be installed in the ceiling above chart-table, radar console, GMDSS console, engine telegraph and steering stand.

Note:

When the microphone is attached in the ceiling with the height of 2 m, it can record in the range with a diameter of 10 m.

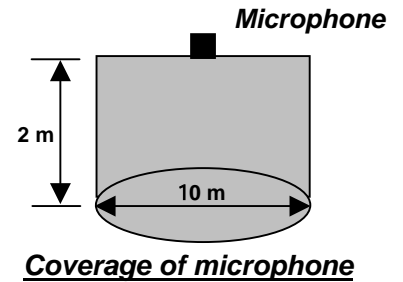

Around the ceiling near the GMDSS console

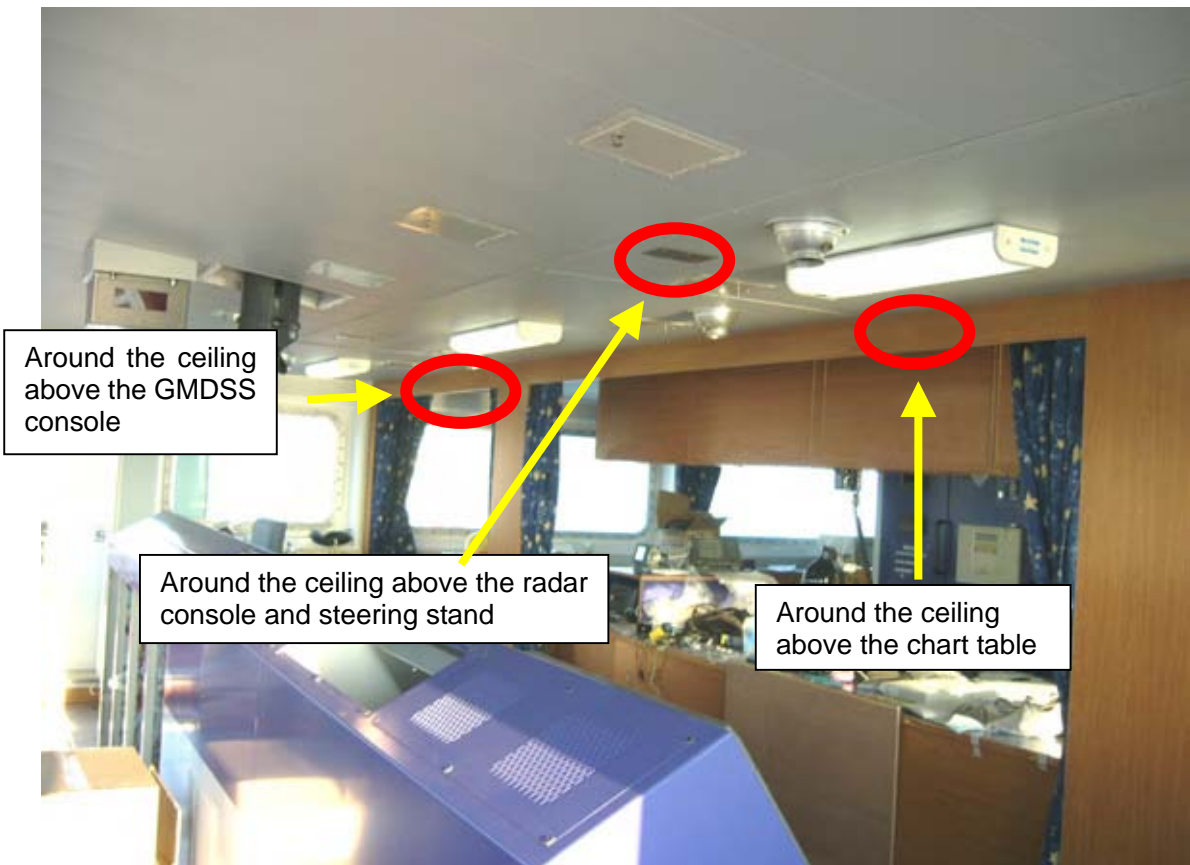

Fig. 9.2.2 Example of mounting the microphone

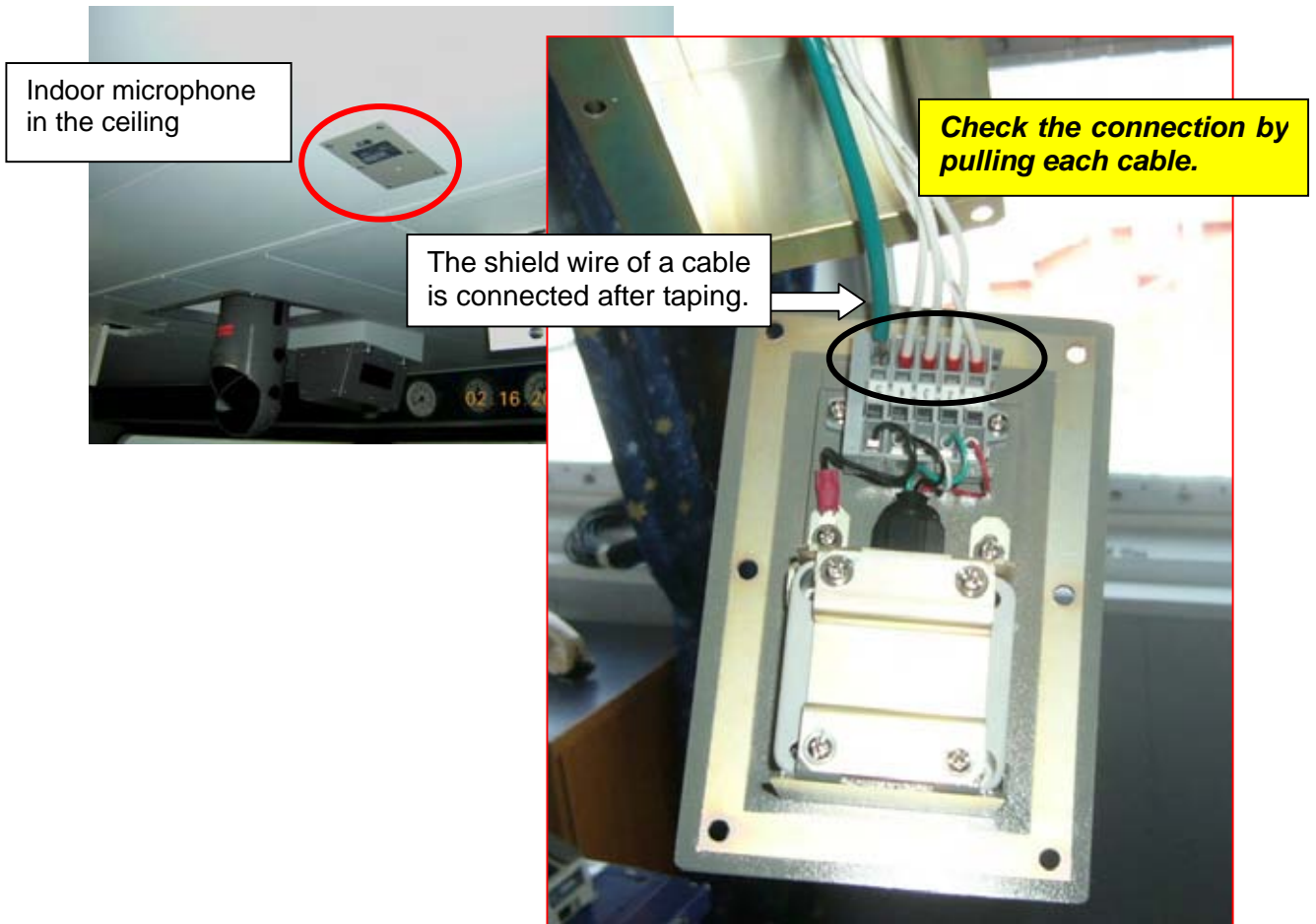

Fig. 9.2.3 Microphone installed in bridge-1



Fig. 9.2.4 Microphone installed in bridge-2

9.2.3 Mounting of Wing Microphone

On the large-size vessel, which equips steering stand at the wing, install a microphone at where the conversation of wing area can be recorded.

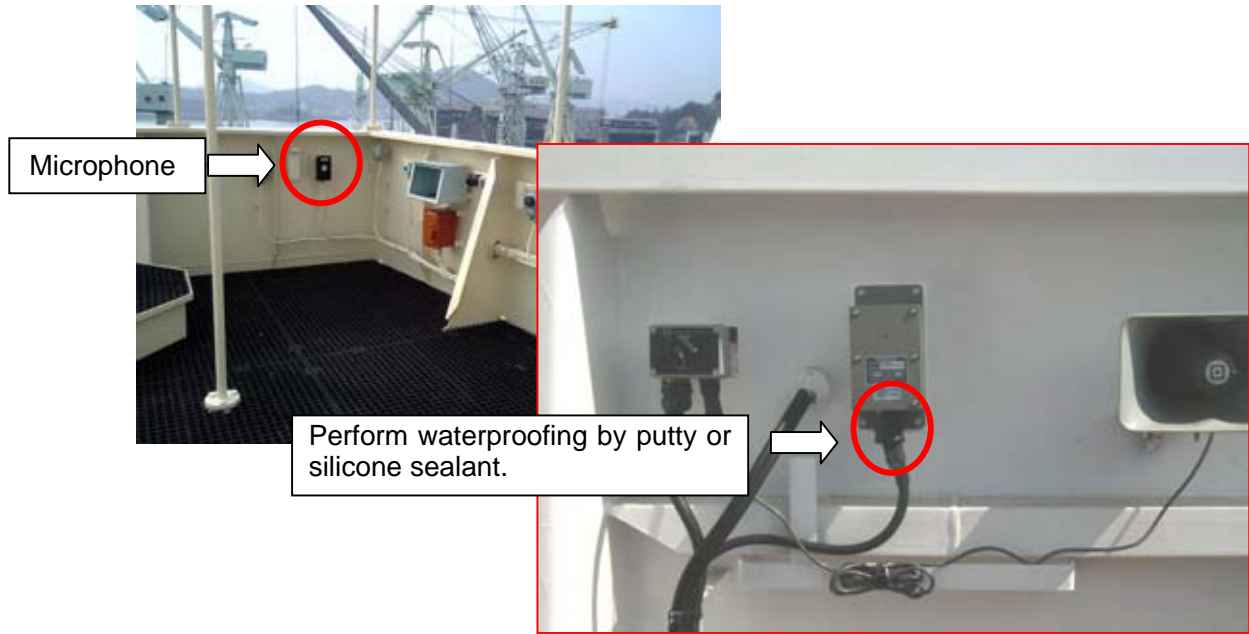

Fig. 9.2.5 Microphone installed in wing area-1



Fig. 9.2.6 Microphone installed in wing area-2



Fig. 9.2.7 Microphone on the steering stand of wing

9.3 VR-5000/VR-3000: Installation of DRU

9.3.1 Mounting of DRU

The DRU contains a protective capsule and it should be installed in the vicinity of the bridge on the open deck area of the vessel. This will maximize the probability of its survival and facilitate recovery following an incident. The DRU should be positioned clear of rigging and other potential obstructions and as near to the centerline of the ship as possible. Constructing a “fence” around the DRU is recommended.

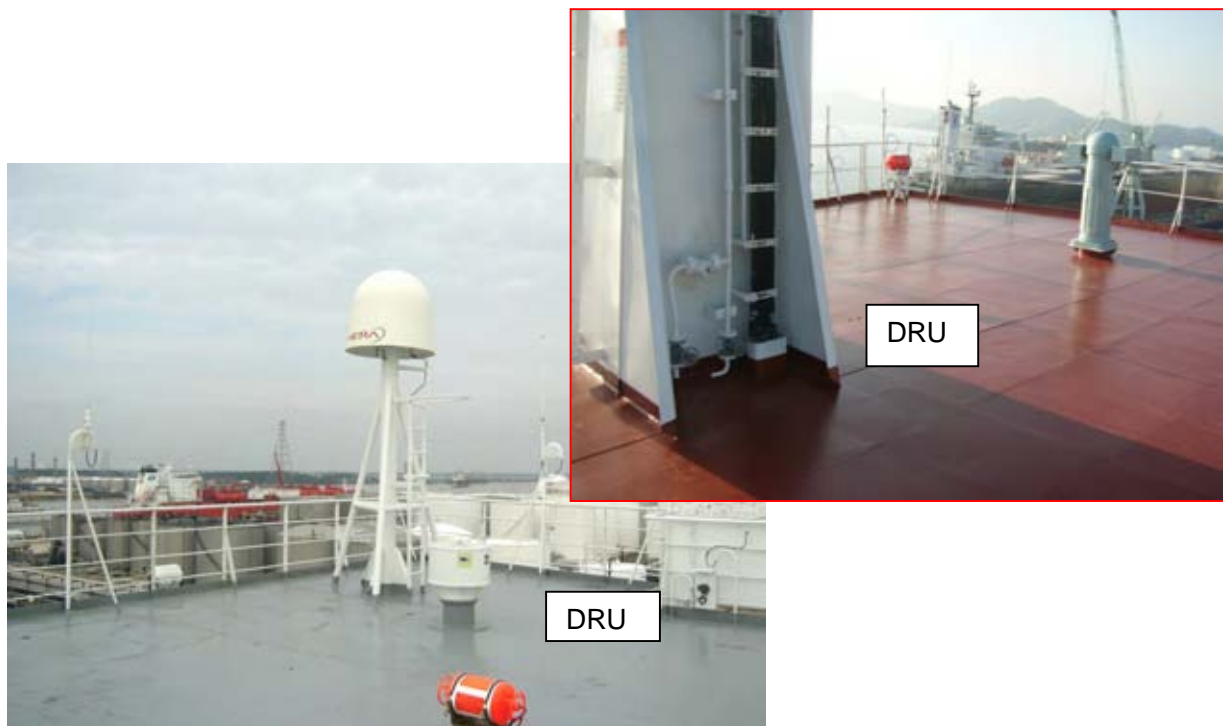

Fig. 9.3.1 Position of DRU



Fig. 9.3.2 Do not cover the DRU

The important matter of the DRU attachment place.

- Must be separated from fuel or other potential fire hazards.
- Must be separated from probable sources of mechanical damage.
- Must be installed in a place that facilitates routing maintenance and copying of recorded data.
- Must be installed where a diver or remote operated vehicle could remove and retrieve.
- There should be a clear and unobstructed area around the DRU to allow a diver or an ROV to work.

Note:

When installing the fire wire cable, protect the connector of fire wire from damages by taping etc.

9.3.2 Fixing DRU

The Data Recording Unit comes with the mounting bracket fitted. Require to a shipyard to construct a mounting base of the DRU. On the mounting base, mount the bracket with M8 bolts and nuts (double nuts). The gap between vibration absorber and bolt should be at least 3 mm.

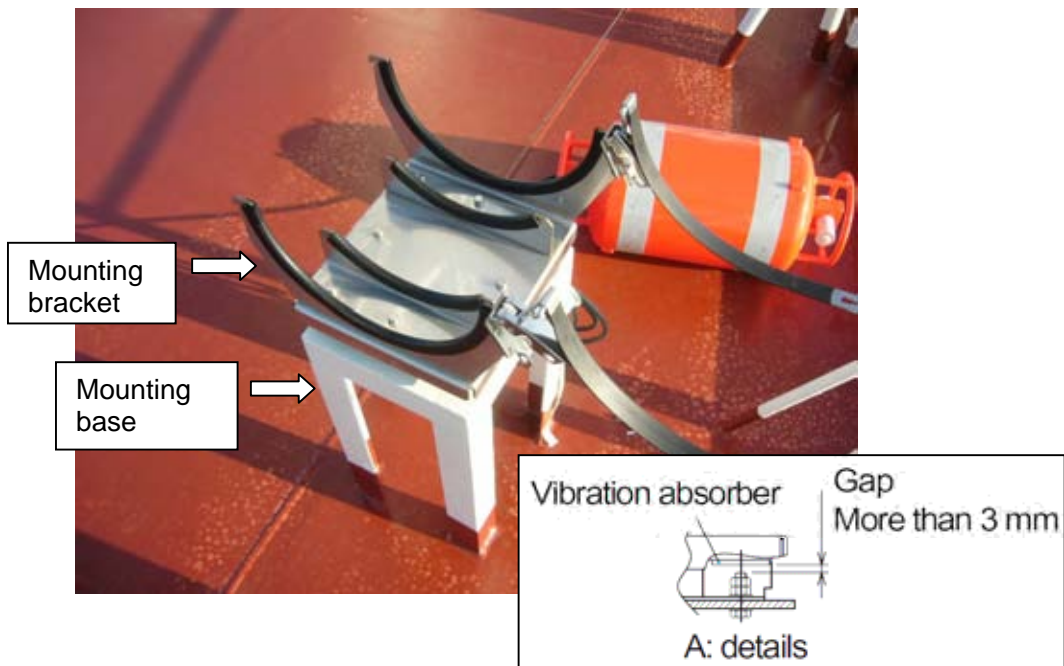

Fig. 9.3.3 Mounting base of DRU

9.3.3 Connection of DRU

Insert the IEEE1394 plug of fire wire into the receptacle securely.

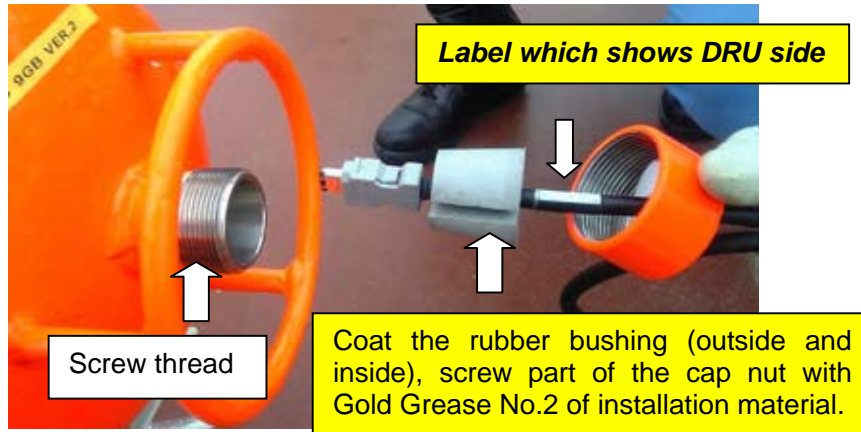

Fig. 9.3.4 Connecting fire cable to DRU

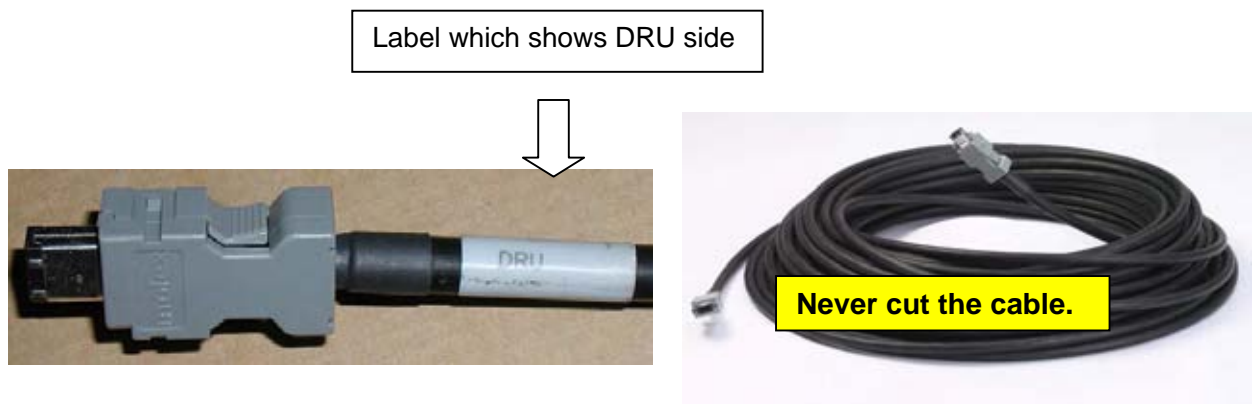

Fig. 9.3.5 Fire wire cable

Note:

Protect the connector by taping in order to prevent damaging when cabling the fire- wire cable. And waterproof the connector if it is left out of doors.

Fasten cap-nut of DRU leaving “One-Thread” as shown bellow.

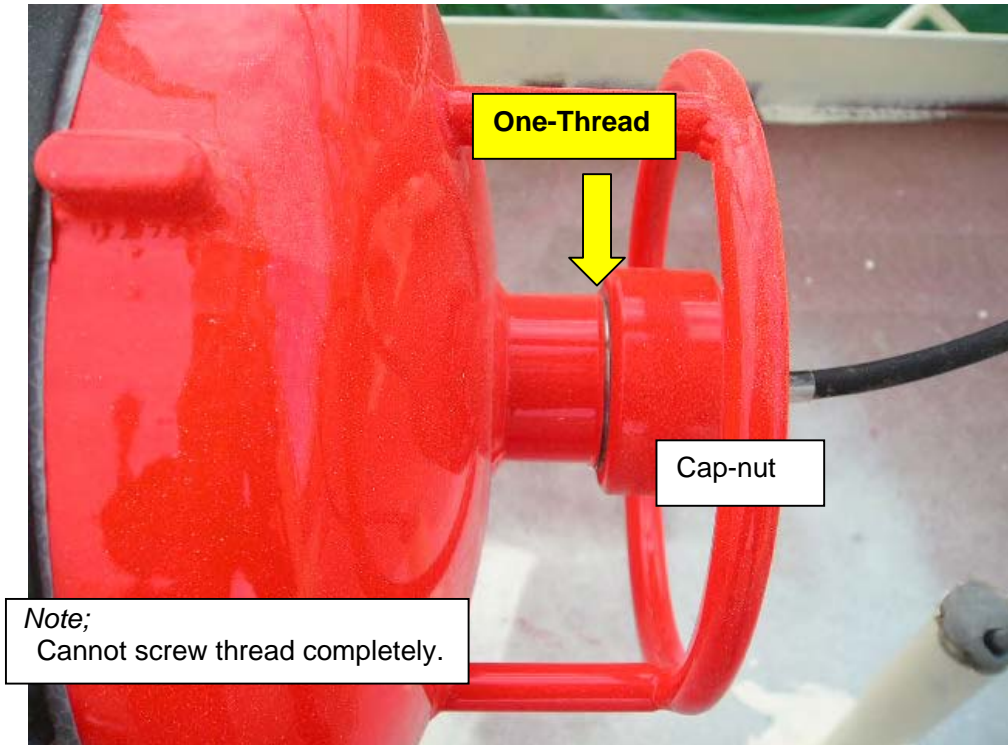

Fig. 9.3.6 Fixing cap-nut

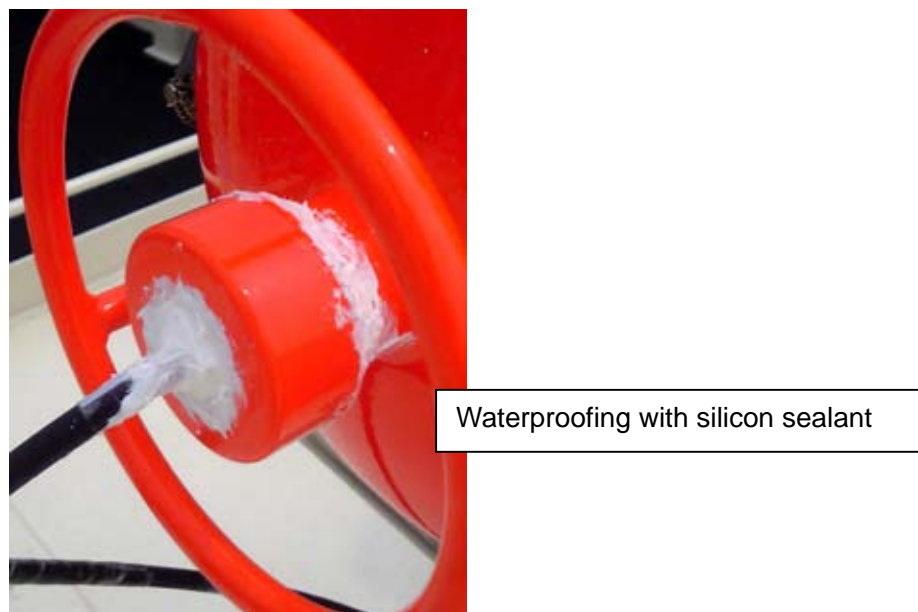

Fig. 9.3.7 Waterproofing

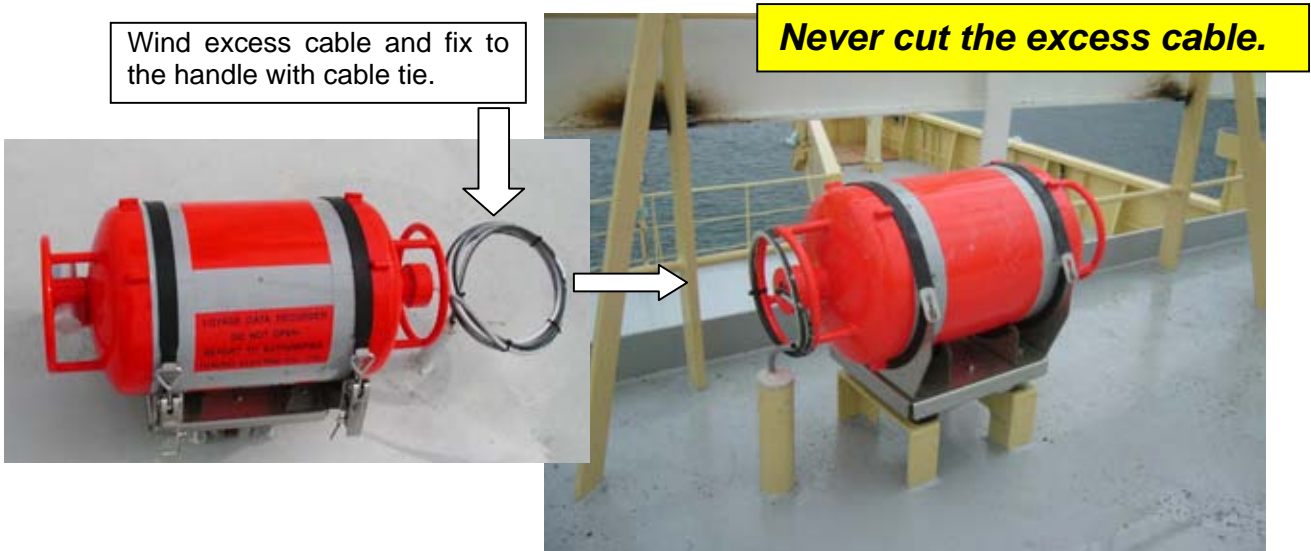

Fig. 9.3.8 Installation of DRU-1

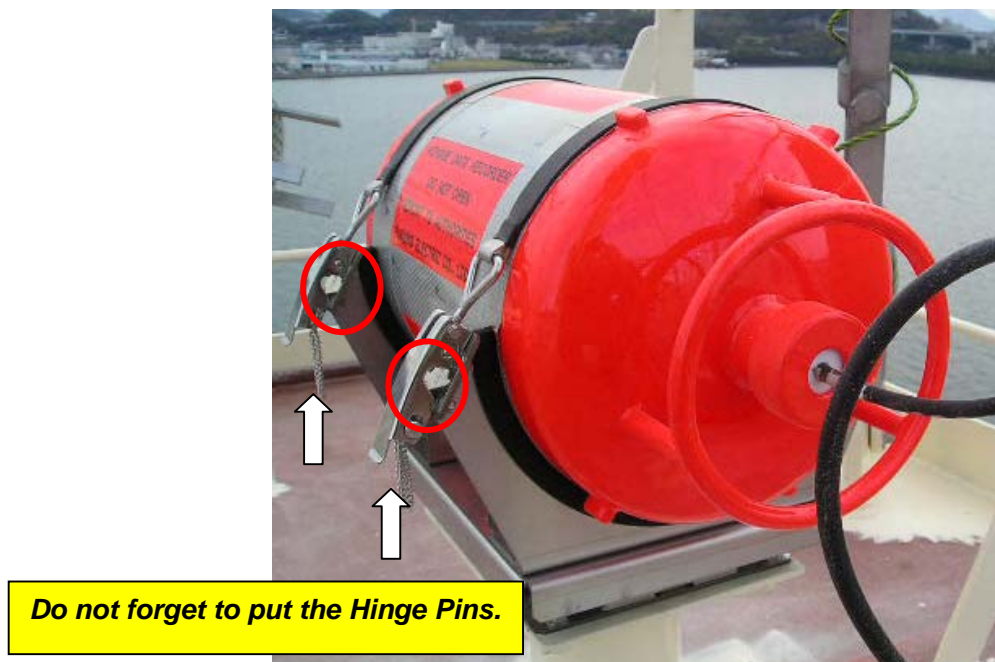

Fig. 9.3.9 Installation of DRU-2

9.4 Installation of VR-3000

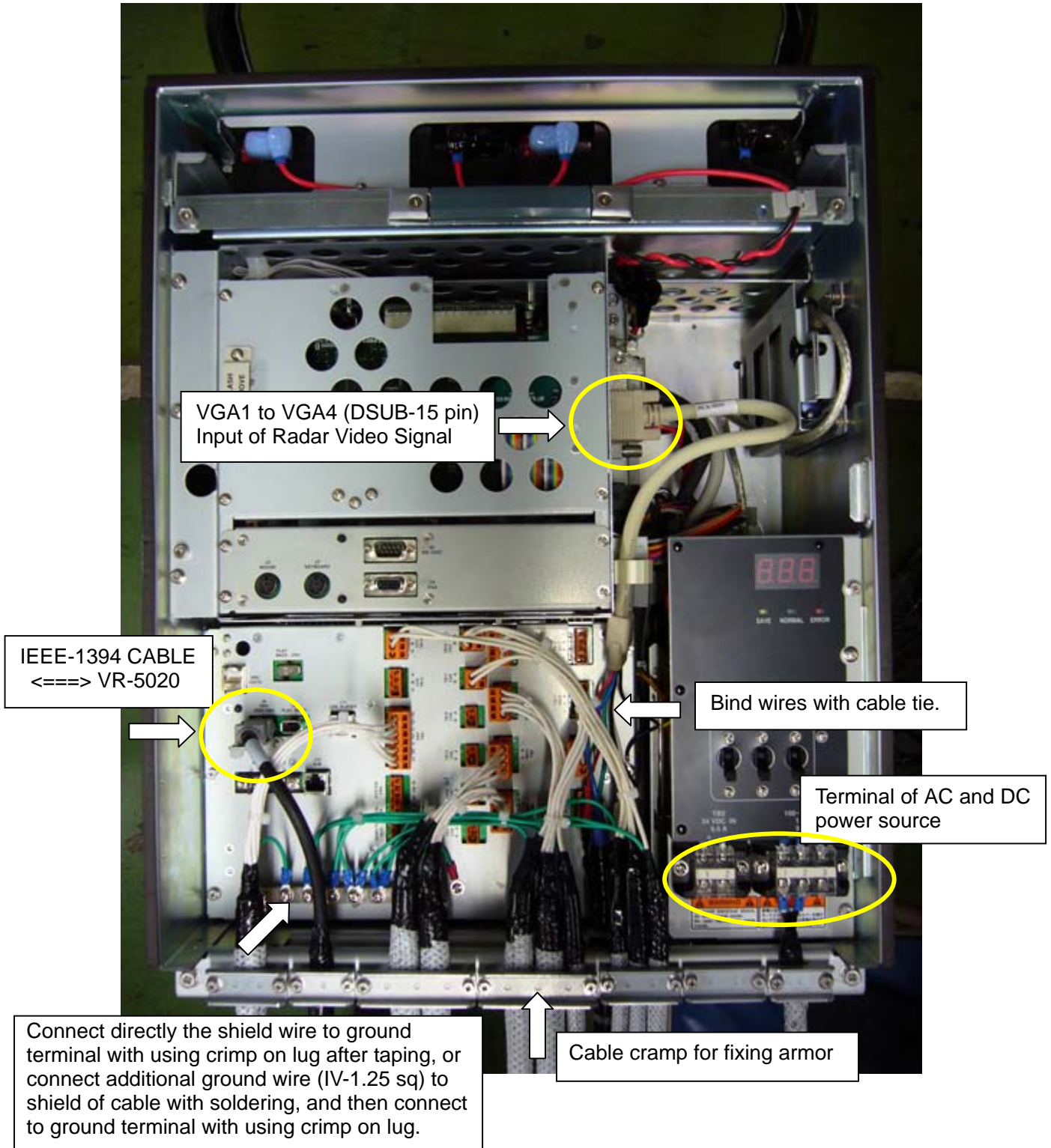

Fig. 9.4.1 Connection of DCU

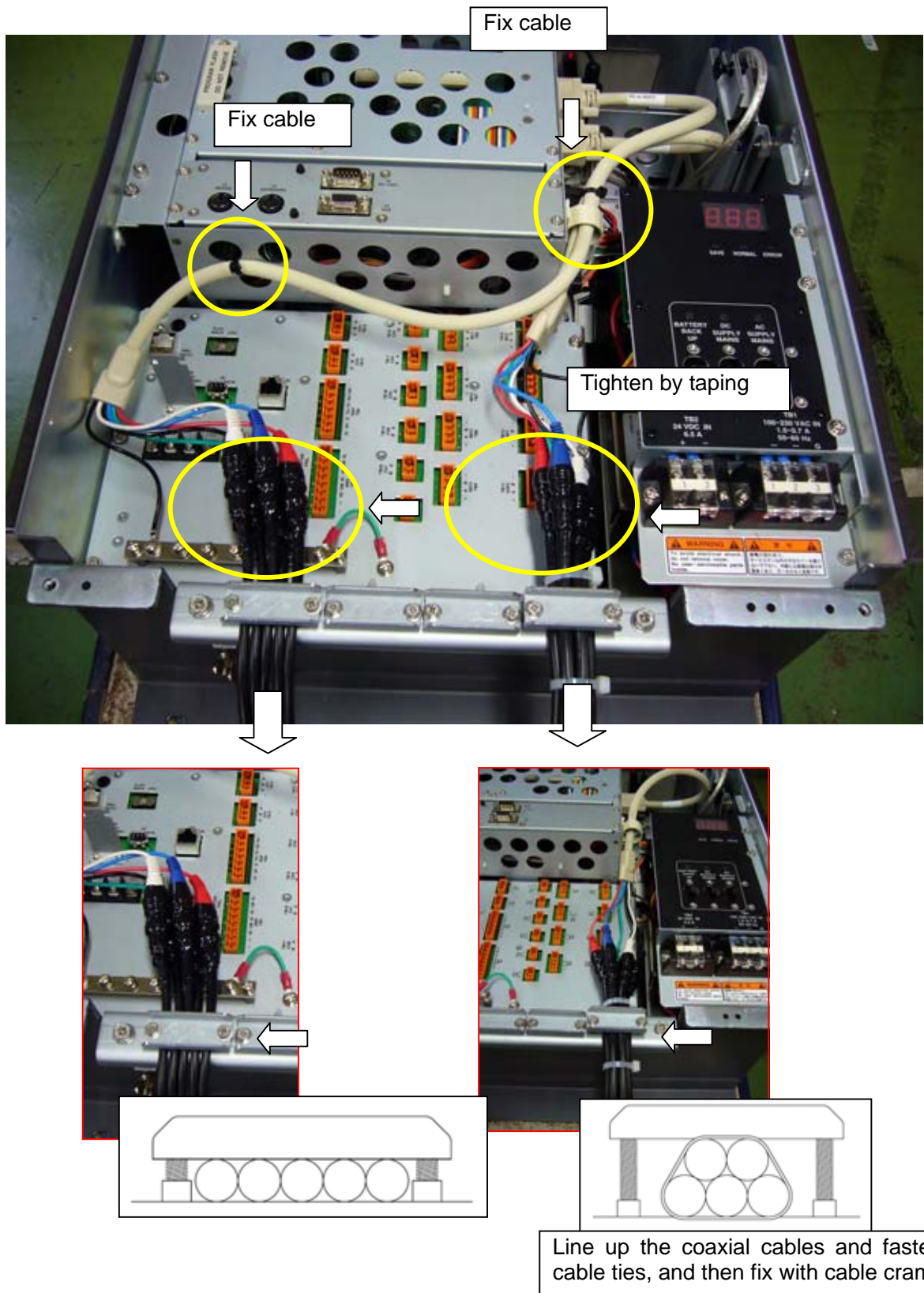

Fig. 9.4.2 Fixing coaxial cable

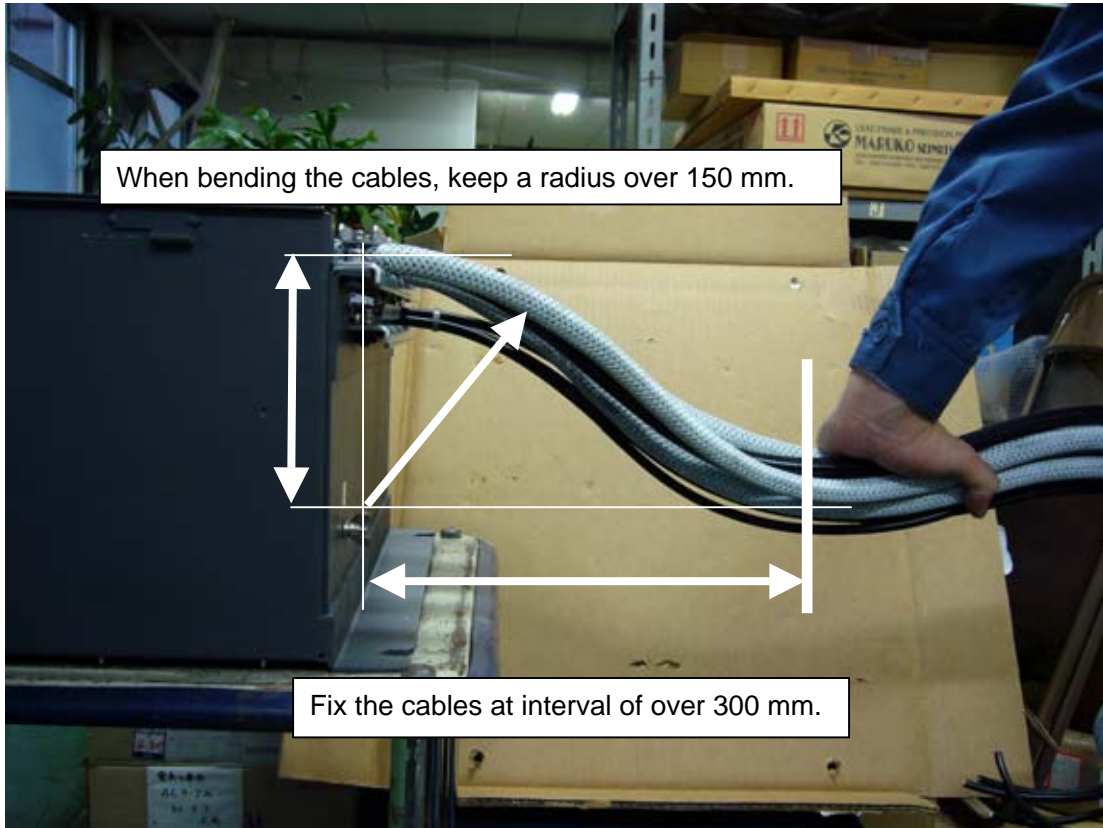

Fig. 9.4.3 Fixing cables

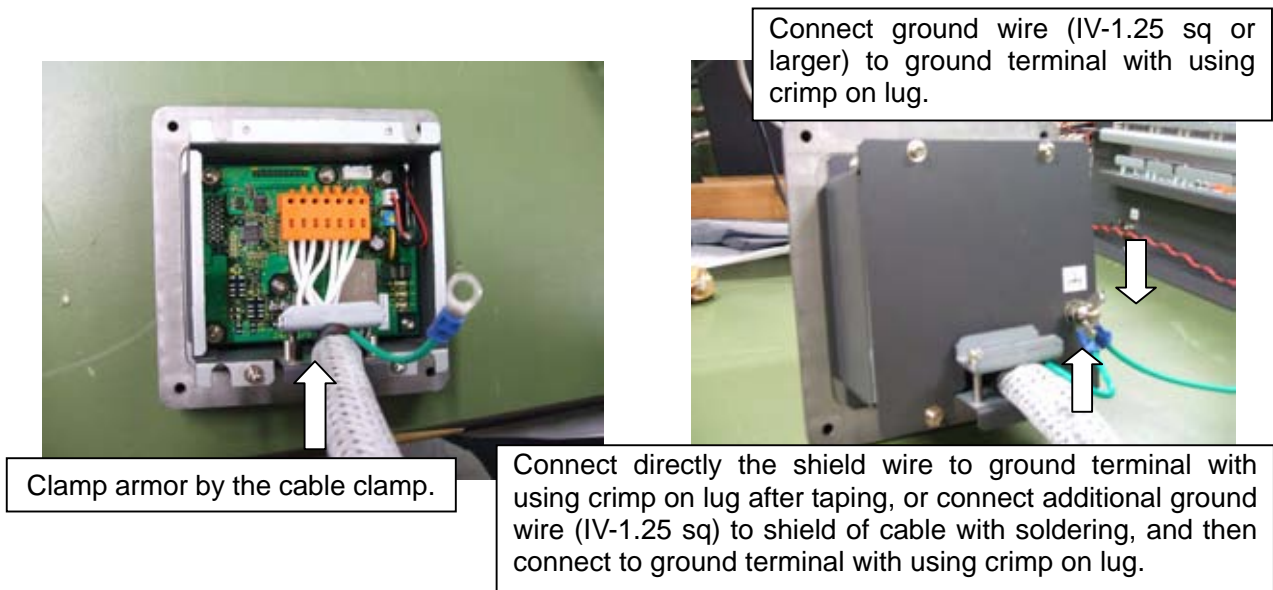

Fig. 9.4.4 Remote Alarm Panel

Chapter 10. Life-saving Appliance

10.1 Installation of SART

Generally the SART is installed near the door either port or starboard side on the bridge.

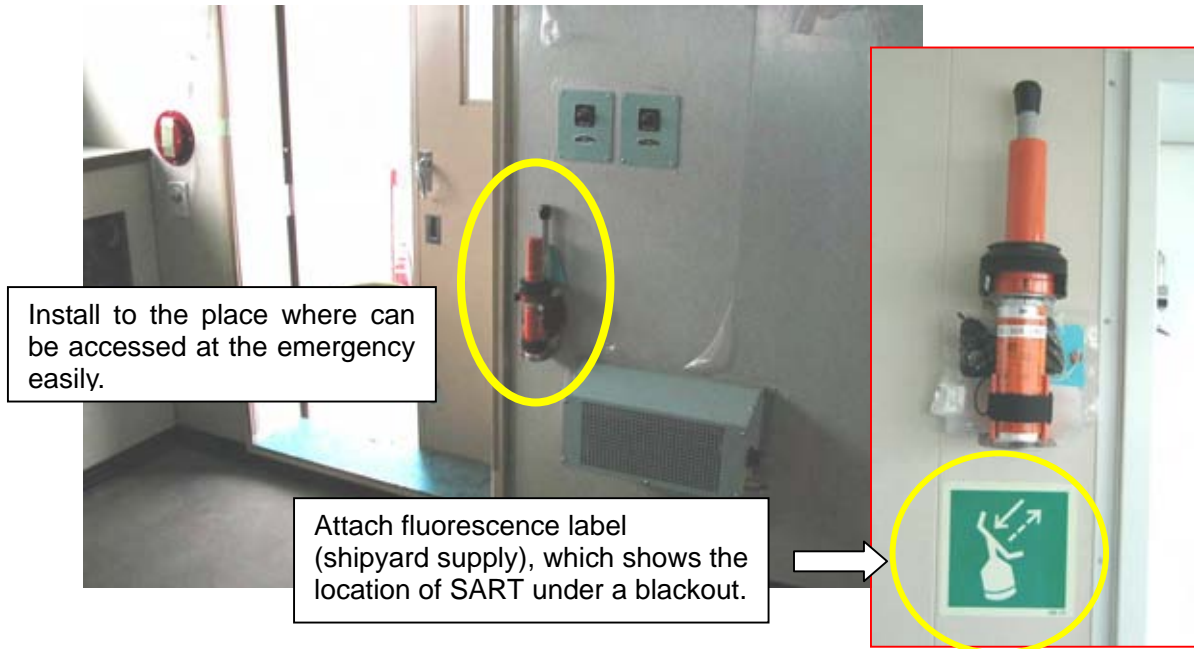

Fig. 10.1.1 Installation of SART

Installing of the SART mounting bracket onto the lifeboat



Fig. 10.1.2 Location of SART mounting bracket

10.2 Installation of Two-Way VHF Radio

Set the switch either 110 V or 220 V according to the ship's main, and change the fuse accordingly. The switch and fuse are set for the ship's main 220 VAC in the factory.

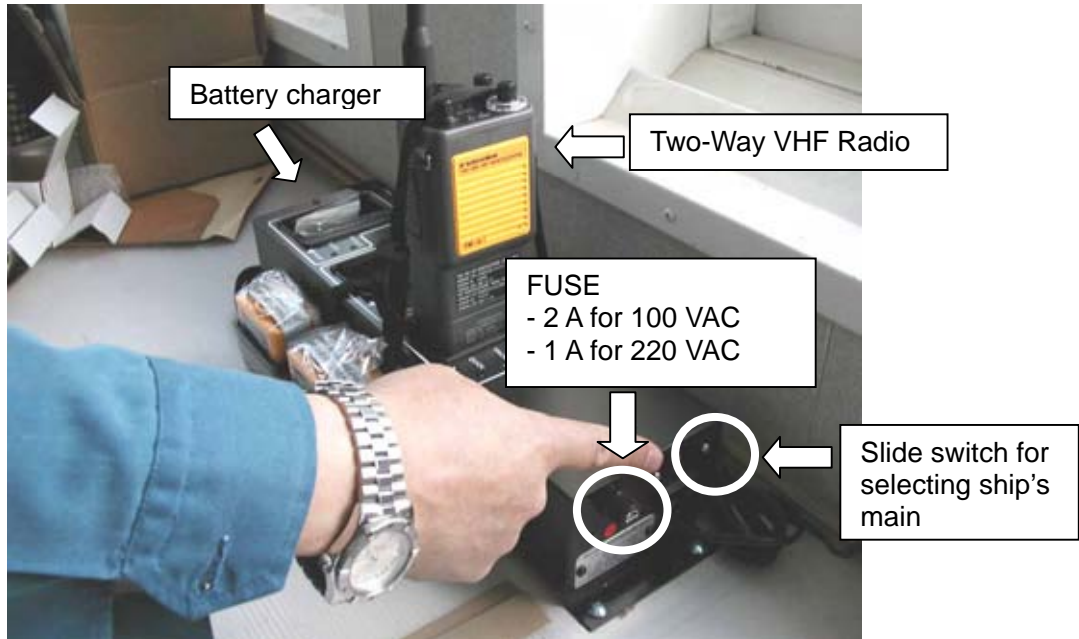

Fig. 10.2.1 Installation of Two-Way VHF Radio-1

Attach lithium batteries (BP-1208) beside the Battery charger.



Fig. 10.2.2 Installation of Two-Way VHF Radio-2

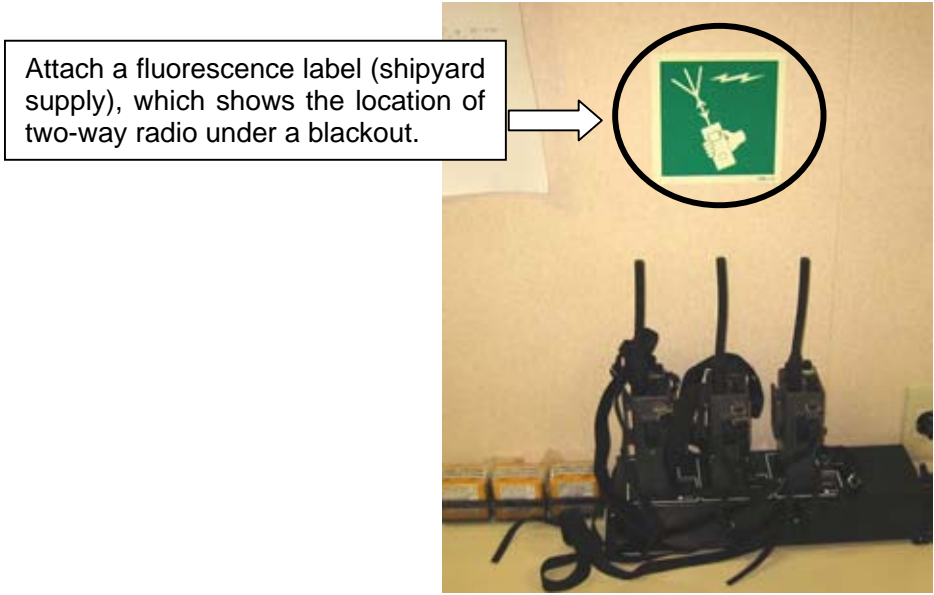

Fig. 10.2.3 Installation of Two-Way Radio

Safety link

Instrument to prevent the strap from being caught on an object. About 35 to 45 kgf force is necessary to release the Safety link from the strap. The Safety link facility is mandatory on all IMO vessels for safety purpose from July 1, 2005. The Safety link does not come off when the radio is dropped.



Fig. 10.2.4 Safety Link

10.3 Installation of EPIRB

Install the EPIRB to be float, when the EPIRB container cover is opened completely.

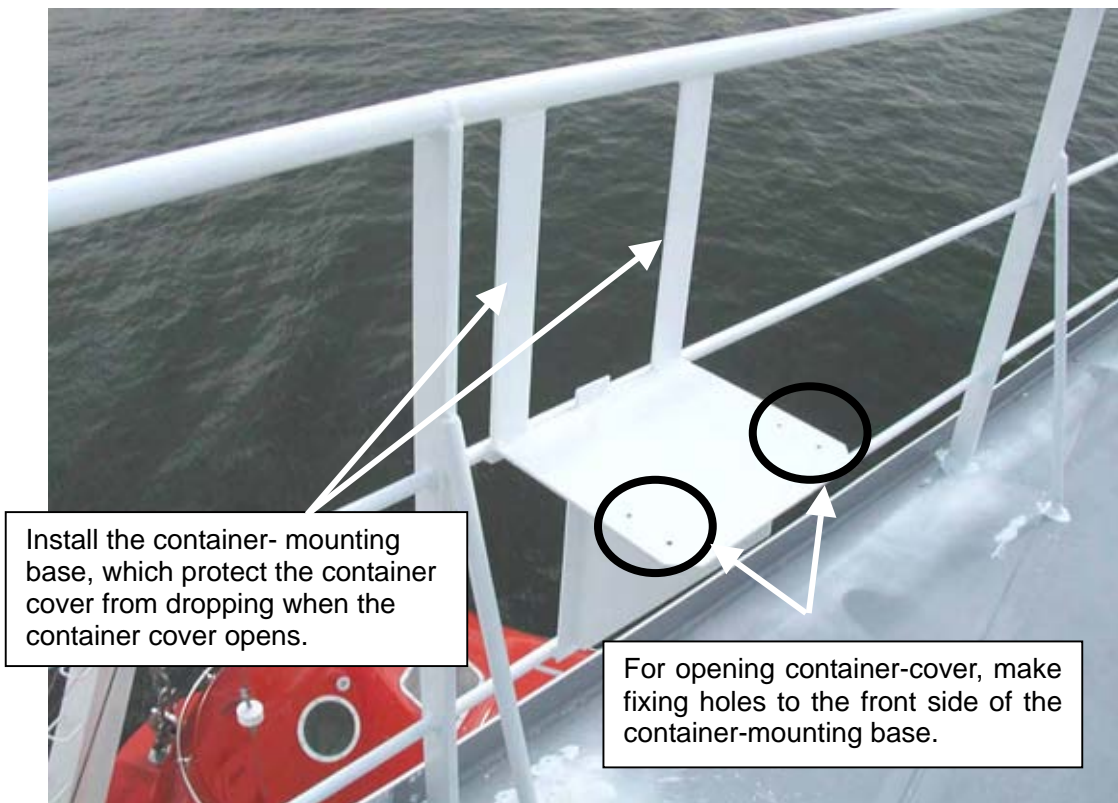

Fig. 10.3.1 Container-Mounting base



Fig. 10.3.2 Locating of EPIRB



Fig. 10.3.3 Mounting of EPIRB

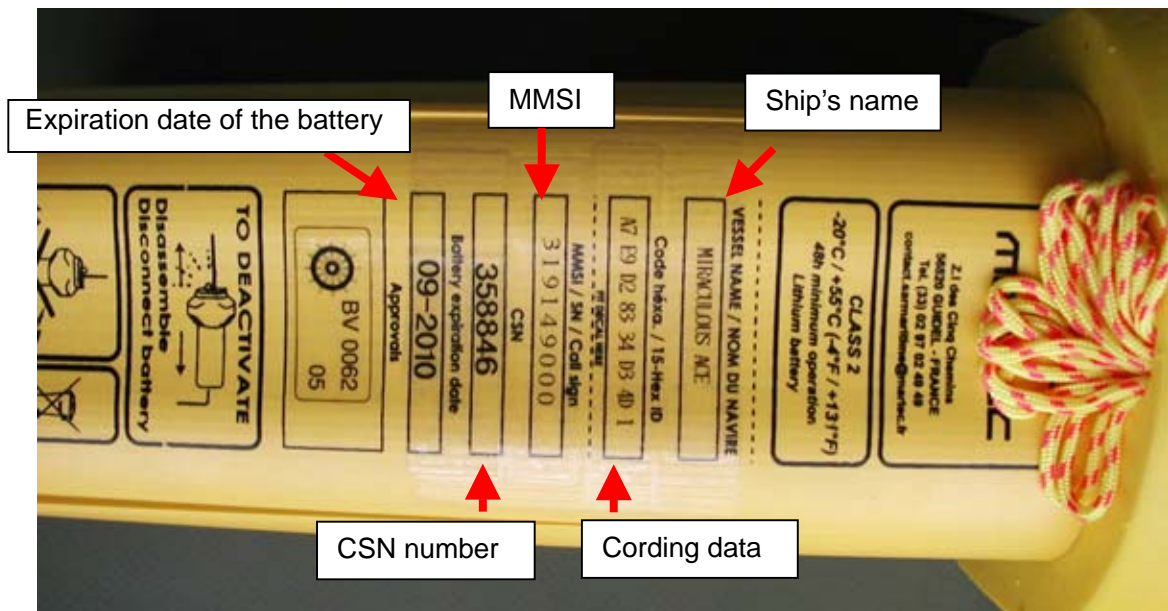

Fig. 10.3.4 Display on EPIRB

Chapter 11. Navigational Echo Sounder

11.1 Laying the Transducer cable

Pass the cable through pipe or on the cabling from the transducer flange to the transceiver unit or matching box. The cable must be fixed well to prevent the damage caused by vibration.

Do not lay the transducer cable together with the cable of power supply and others.

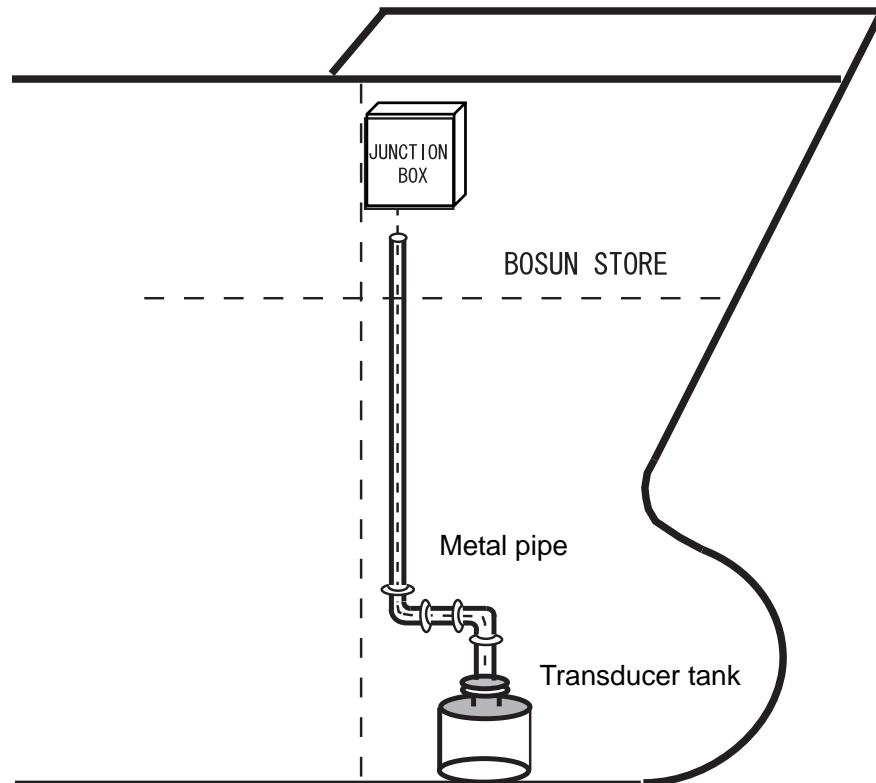
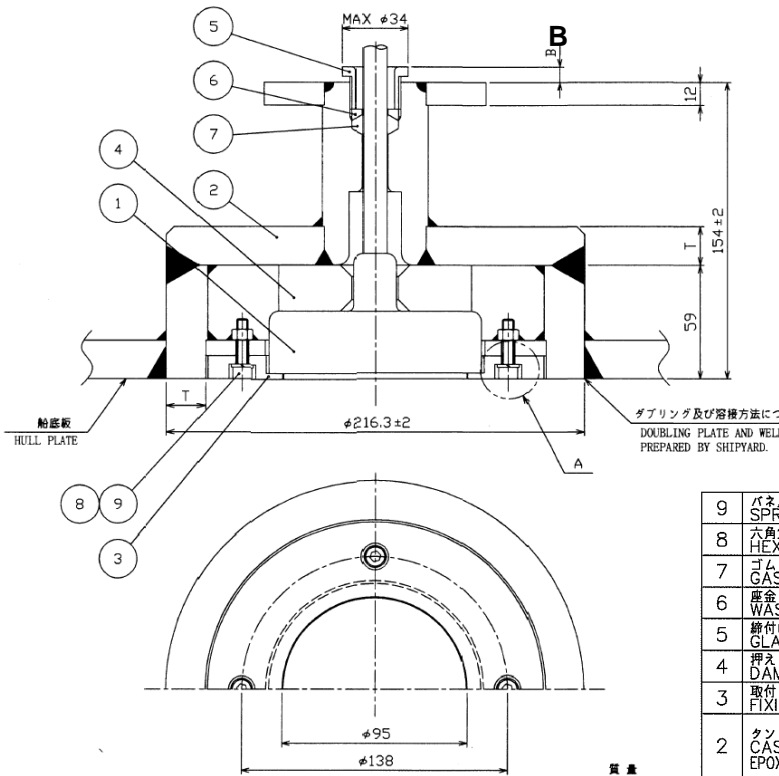

Fig.11.1.1 Piping transducer cable

11.2 Inner Hull Tank

- Install the tank parallel to draft line longitudinally and transversely.
- Remove the paint at the welding part of the tank.
- Before welding the tank, remove the damper and gasket to prevent the damage caused by the welding heat. Never do welding with transducer mounted.
- When fixing the tank, put fixing flange to tank in order to prevent the tank from distorting with welding heat.
- Do not paint on the transducer face.
- Fasten the cable gland so that the gap B becomes 7.0 mm to 7.5 mm. Too much fastening cause damage of cable.

1. Inner Hull Tank: TTF-2000



9	バネ塵金 SPRING WASHER	SUS316L	4	M6	
8	六角穴付きボルト HEX. S.H.C. SCREW	SUS316L	4	M6×25	
7	ゴムパッキン GASKET	CR	1	TPB-11-08	
6	塵金 WASHER	C3604B	1	TPB-11-07	
5	締付けフランジ GLAND NUT	C3604B	1	JIS F8801 20 1a	
4	押えゴム DAMPER	CR	1	TTF-2000-03	
3	取付フランジ FIXING FLANGE	SUS316L	1	TTF-2000-02	
2	タンク本体 CASING EPOXY ZINC RICH PRIMER	KSTPG370	1	TTF-2000-05	船級認定材 CLASSIFICATION SOCIETY APPROVED MATERIAL
1	送受波器 TRANSDUCER		1	200B-8B	表3質量には含まず NOT INCLUDED IN MASS.
品番 ITEM	品名 NAME	材質 MATERIAL	数量 QTY	図番 DWG.NO.	摘要 REMARKS

Fig. 11.2.1 TTF-2000

2. Inner Hull Tank: TTF-2001

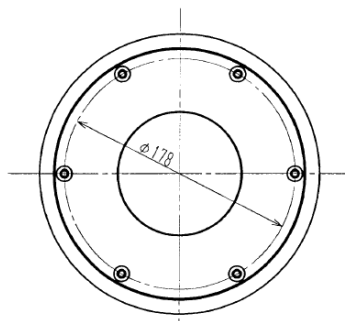
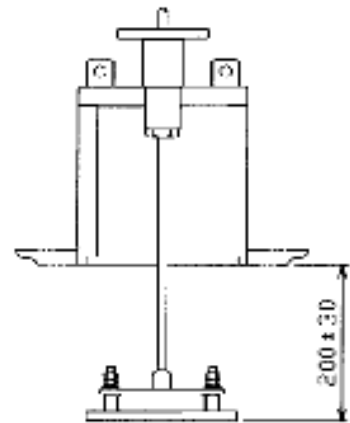
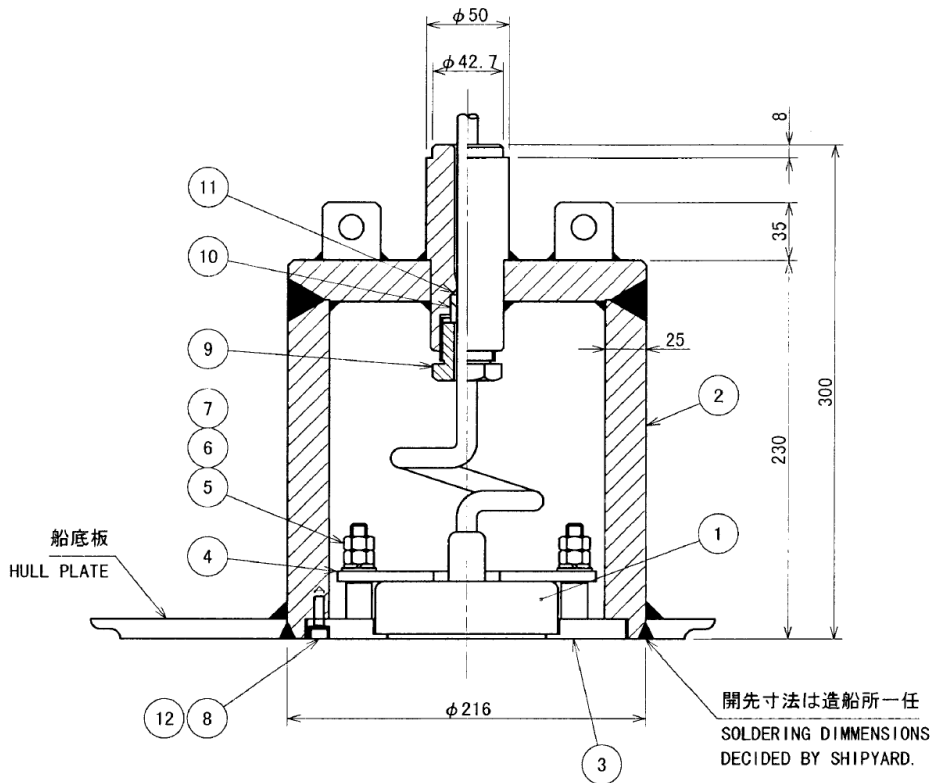

12	バネ座金 SPRING WASHER	SUS304	6	M6
11	防水ゴム PACKING	CR	1	TWB-1009
10	防水ゴム押え金具 WASHER	SUS316	1	65-007-6006
9	締付ナット TIGHTENING NUT	SUS316	1	65-007-6005
8	六角穴付きボルト HEX. BOLT	SUS304	6	M6X20
7	六角ナット HEX. NUT	SUS304	8	M10
6	バネ座金 SPRING WASHER	SUS304	4	M10
5	平座金 FLAT WASHER	SUS304	4	M10
4	押え板 FIXING PLATE	SS400	1	02-129-7012
3	フランジ FLANGE	SUS316L	1	02-129-7011
2	タンク本体 CASING	KSTPG370	1	02-129-6017
1	送受波器 TRANSDUCER		1	200B-8B
品番 ITEM	品名 NAME	材質 MATERIAL	数量 Q'TY	図番 DWG. No.

Fig.11.2.2 TTF-2001

3. Inner Hull Tank: TTF-2002

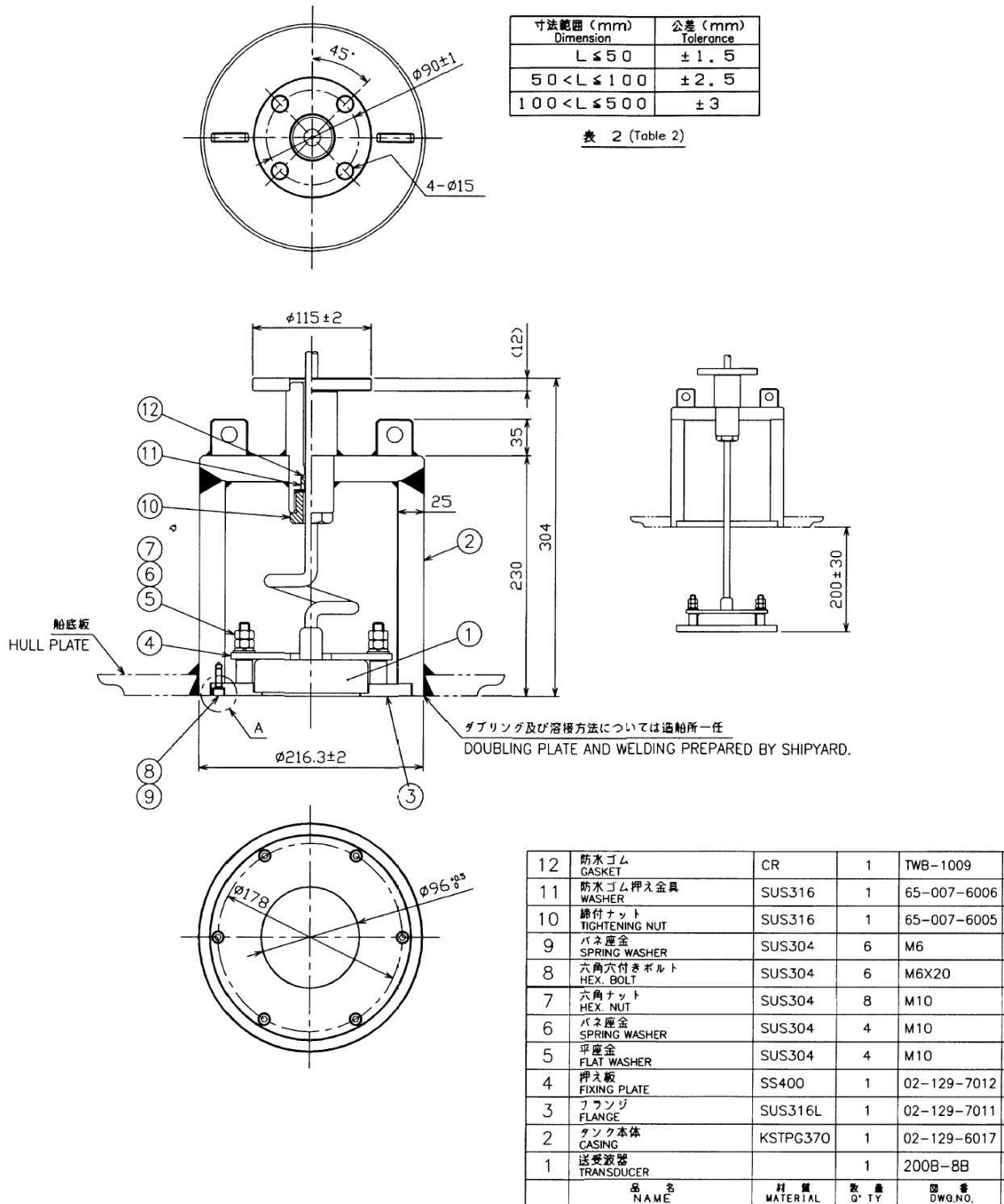

Fig.11.2.3 TTF-2002

4. Inner Hull Tank: TTF-2000-2

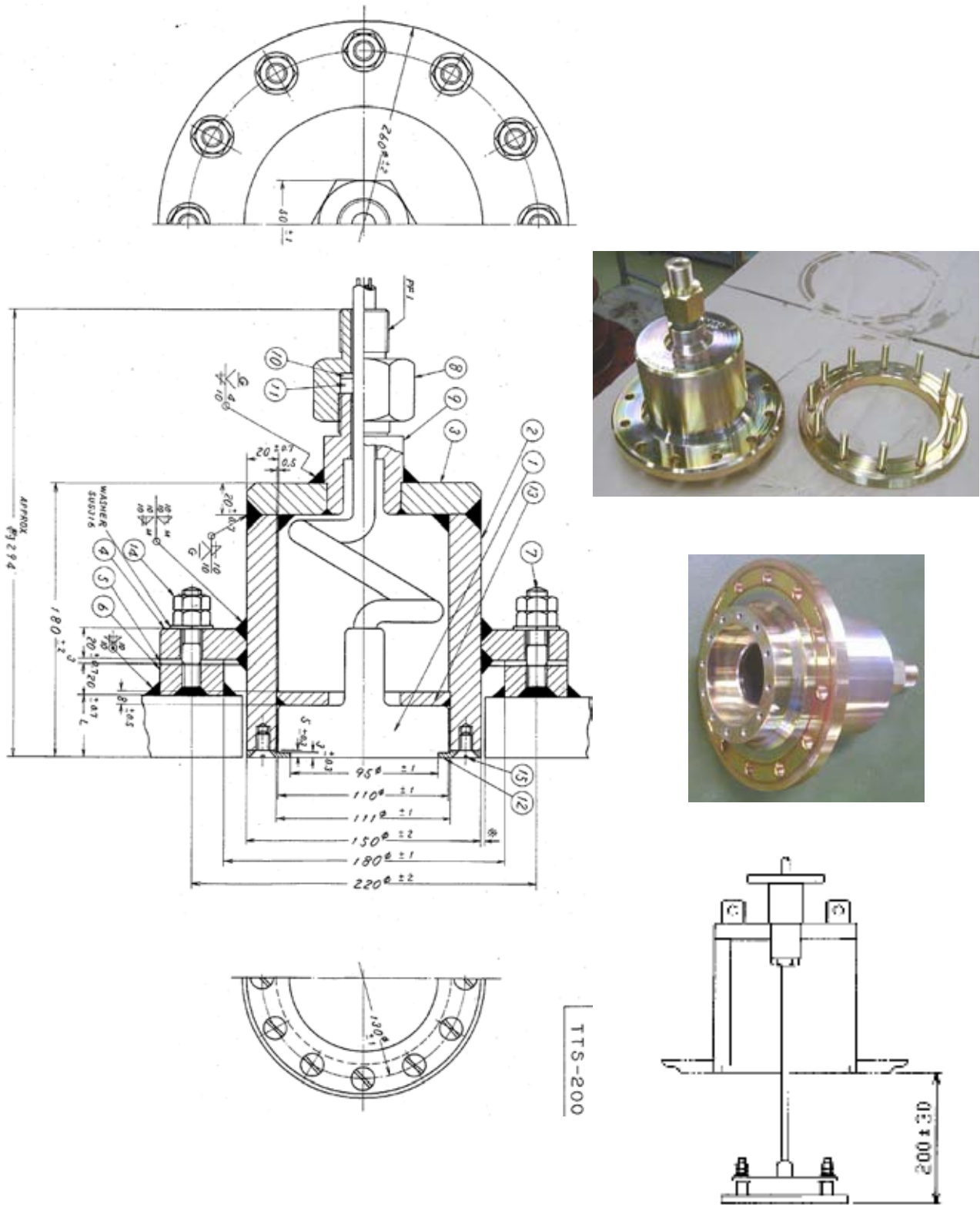

Fig.11.2.4 TTF-2000-2

11.3 Installation of Display unit and Distribution box: FE-700

11.3.1 Mounting of Display unit

The following shows an example of the installation of Display unit: FE-700 on the switch board.



Fig. 11.3.1 Mounting of Display unit

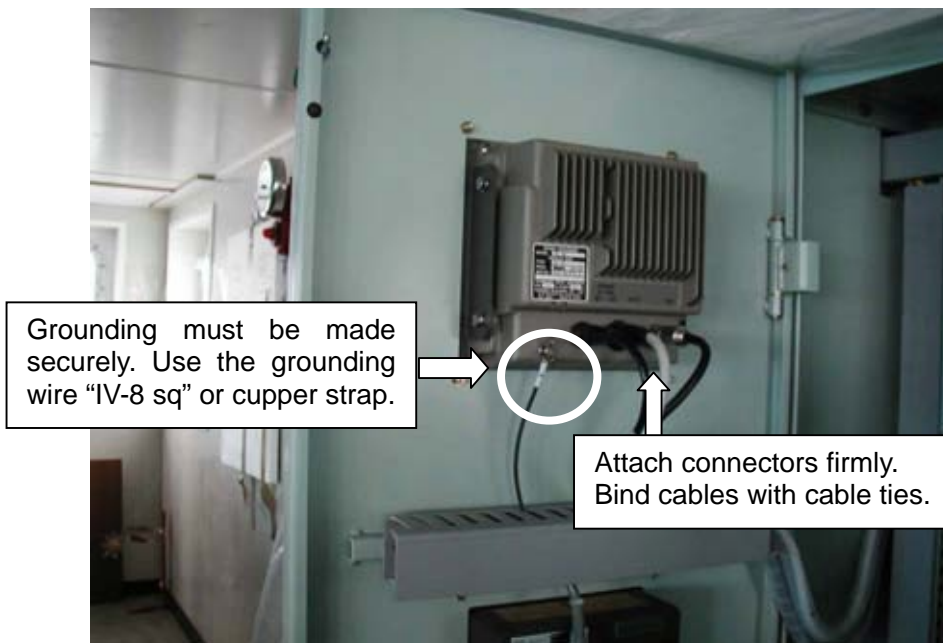

Fig. 11.3.2 Rear side view of FE-700

11.3.2 Mounting of Distribution box

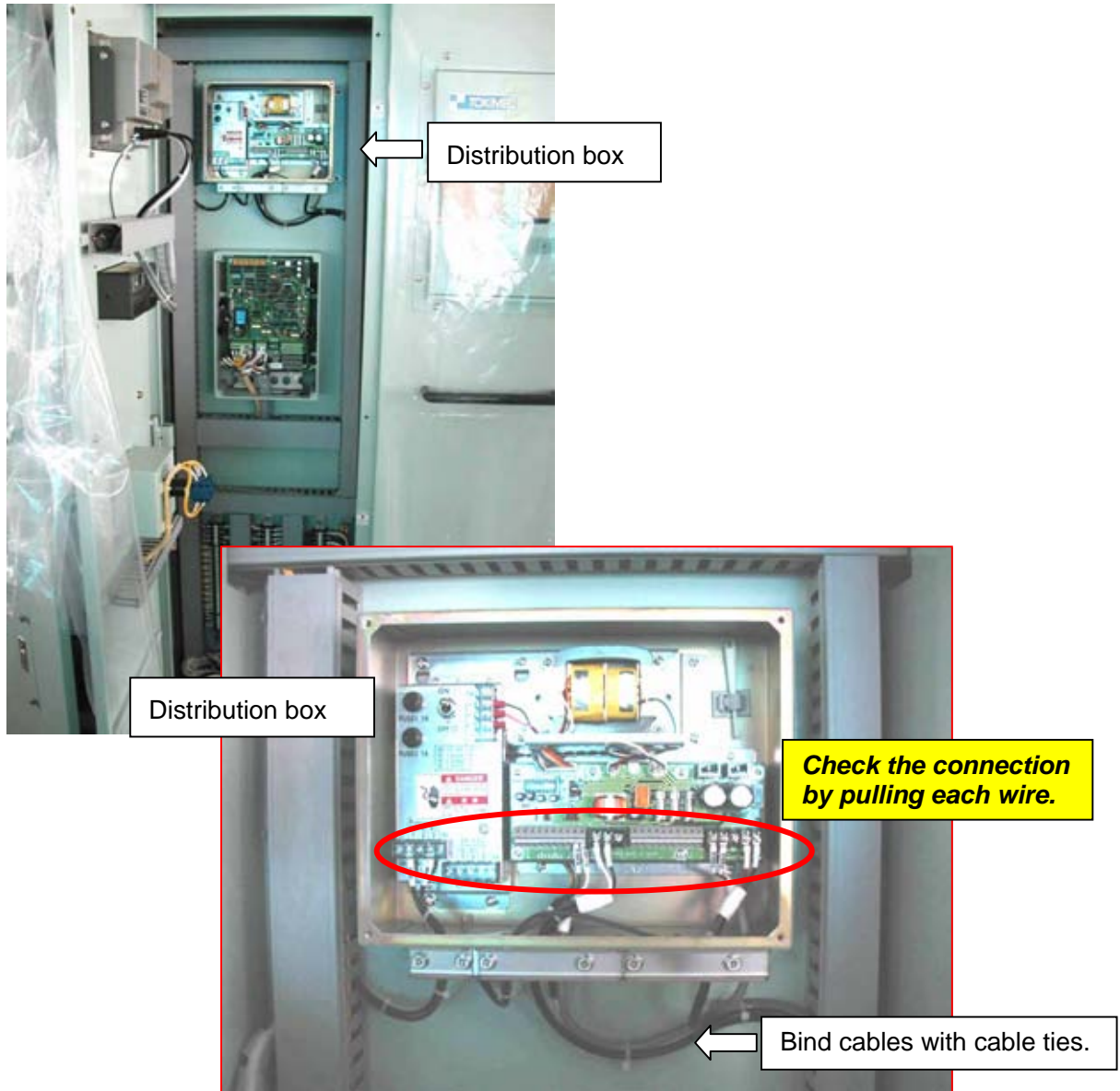

Fig. 11.3.3 FE-700 processor unit, enlarged

11.3.3 Mounting of Matching box

Typically, the matching box is installed in the engine room. Connect the cables correctly. Cut the transducer cable to the proper length.

For 200 kHz Matching box: MB-504

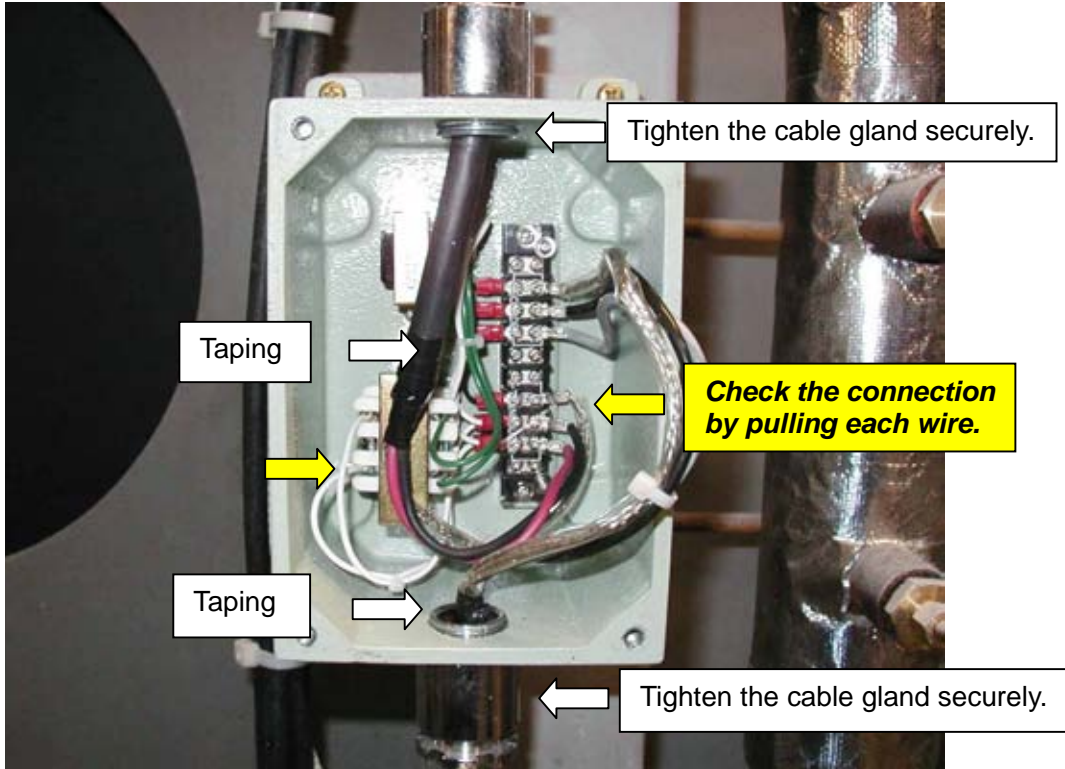

Fig. 11.3.4 Matching box: MB-504

For 50 kHz Matching box: MB-502

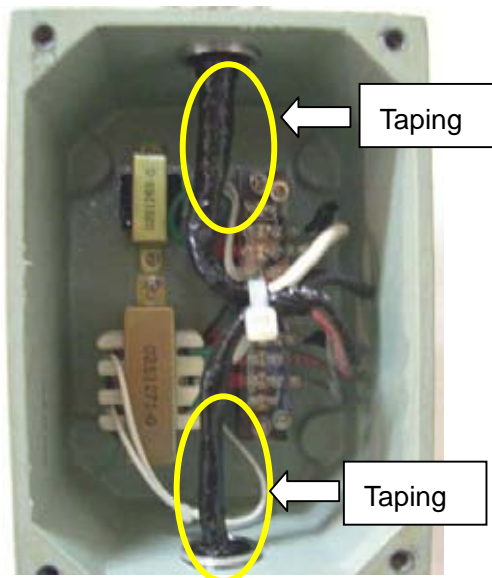

Fig. 11.3.5 Matching box: MB-502

11.3.4 Mounting of Transducer cable/flange

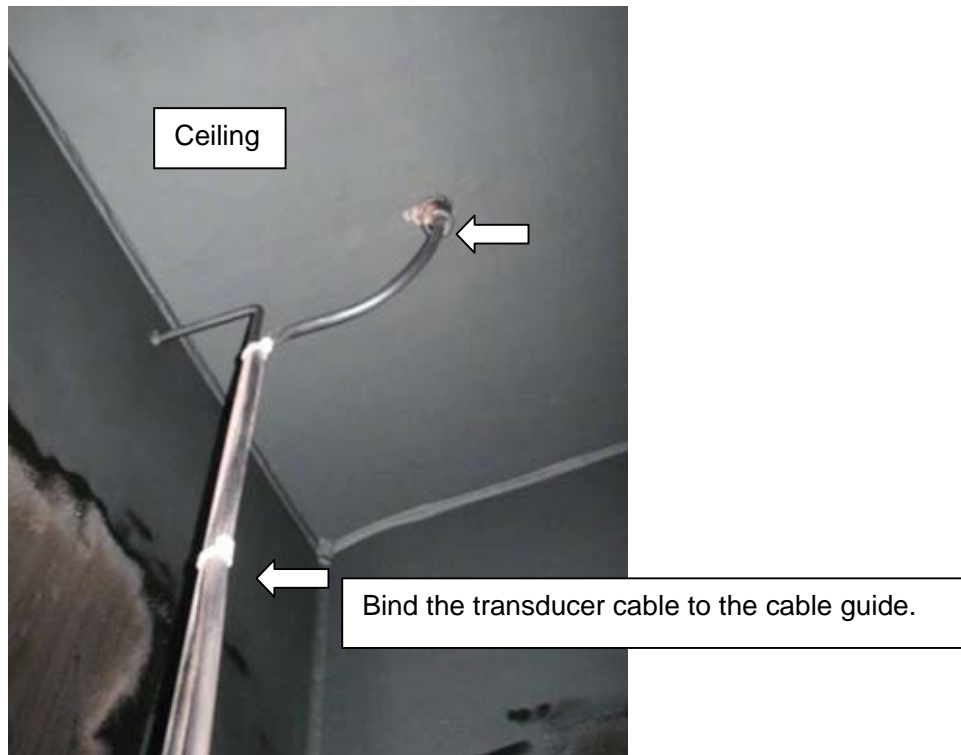

Fig. 11.3.6 Transducer cable-1

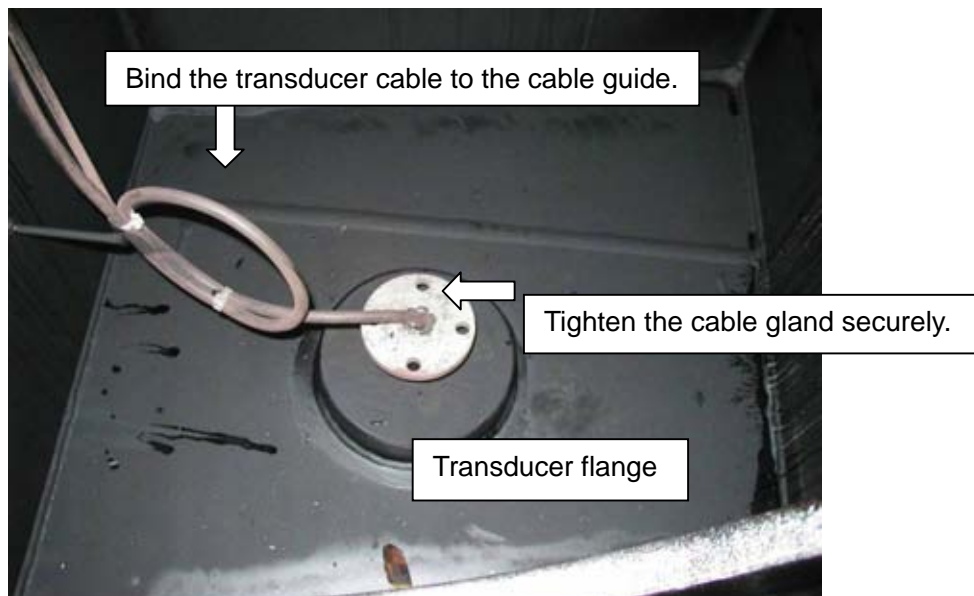

Fig. 11.3.7 Transducer cable-2

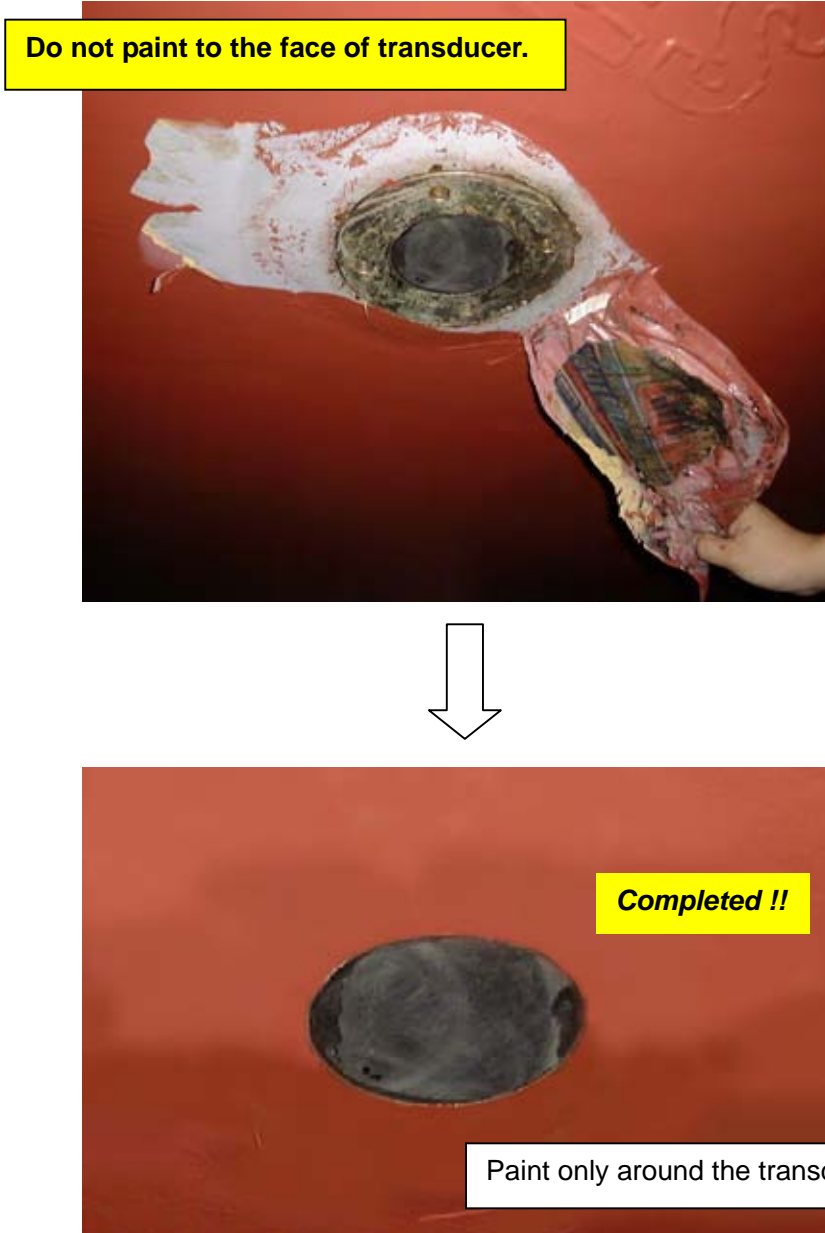

Fig. 11.3.8 Hull bottom

12.1 Laying the Transducer cable

Pass the cable through pipe or on the cabling from the transducer flange to the transceiver unit or matching box. The cable must be fixed well to prevent the damage caused by vibration.

Do not lay the transducer cable together with the cable of power supply and others.

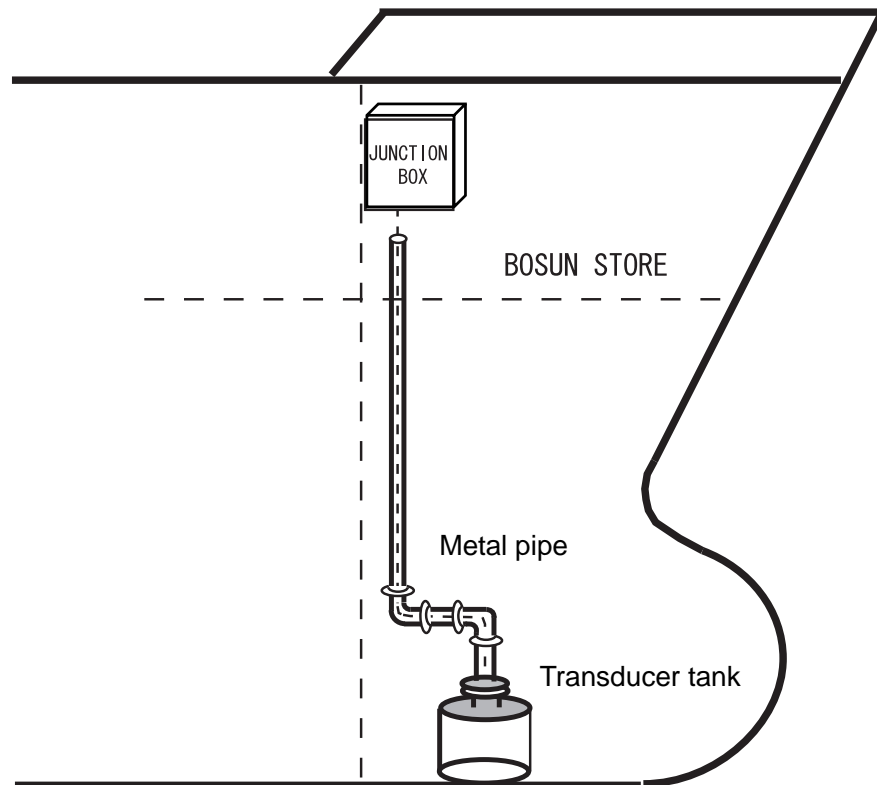

Fig. 12.1 Piping transducer cable

12.2 Installation of DS-30 transducer

12.2.1 Hull fixed tank

1. Align the transducer tank so that the bow mark is in the fore direction.
(The tank supplied by FURUNO carries "bow mark".)

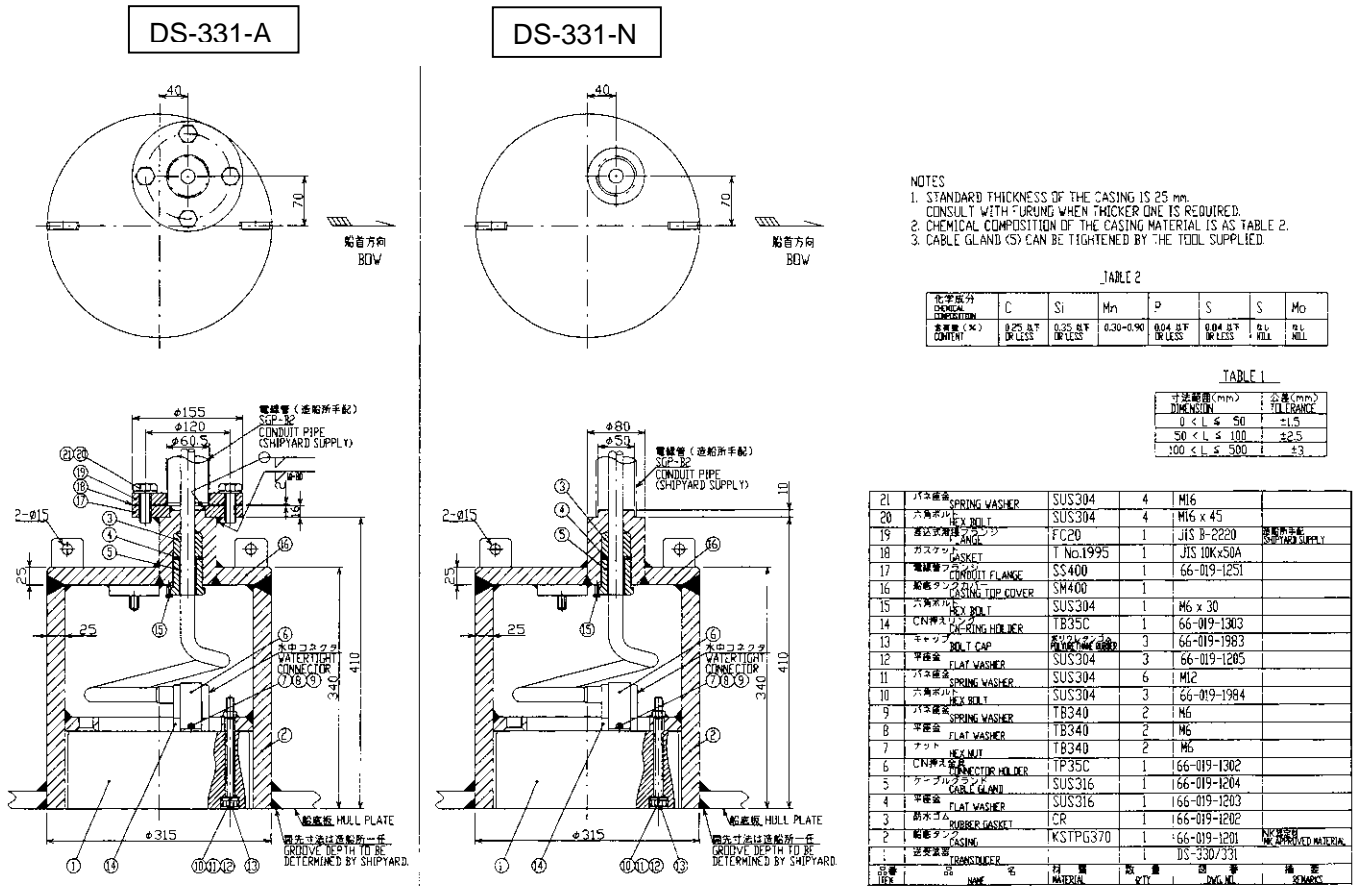

Fig. 12.2.1 DS-331A/331N tank

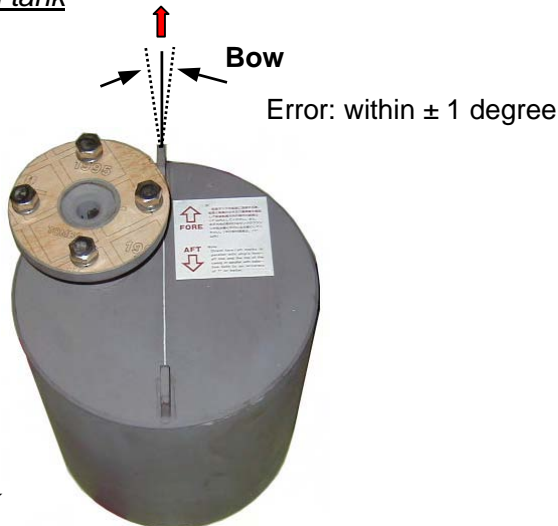

Fig. 12.2.2 DS-331A tank

2. Install the tank parallel to draft line longitudinally and transversely.

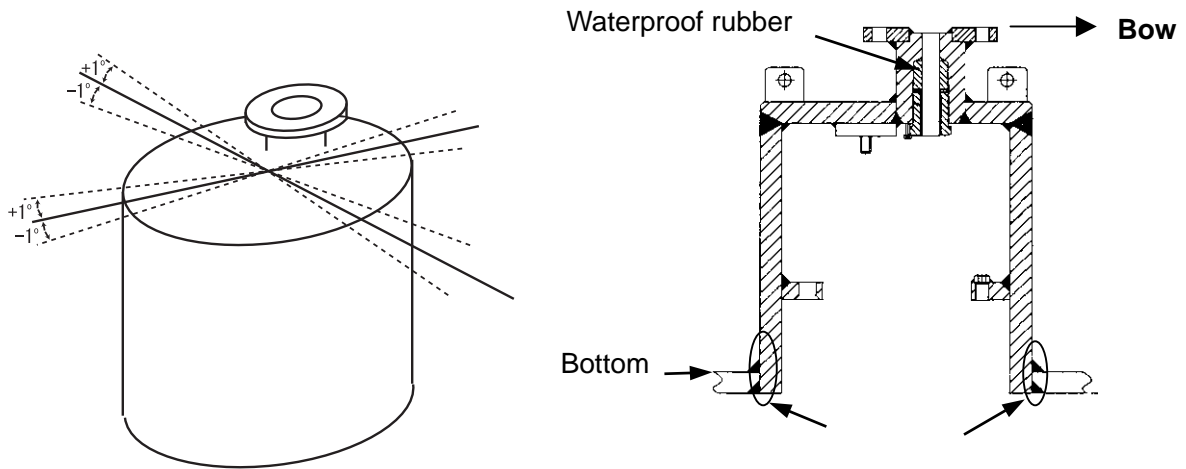

Fig. 12.2.3 DS-331A tank

When welding the tank, remove the waterproof rubber of the transducer to prevent the damage from the heat.

3. Leave a slack of the transducer cable in the tank for servicing.

Procedure

Let the cable gland, flat washer and waterproof rubber through the transducer cable in order.

- 1) Put the cable through the cable gland from the bottom. The length between the connector and the cable gland is 700 to 900 mm. A slack is required for servicing.
- 2) Hand-tighten the cable gland.
- 3) Tighten the gland securely using the wrench supplied.
- 4) Fix the hex-bolt to prevent the gland from loosening.

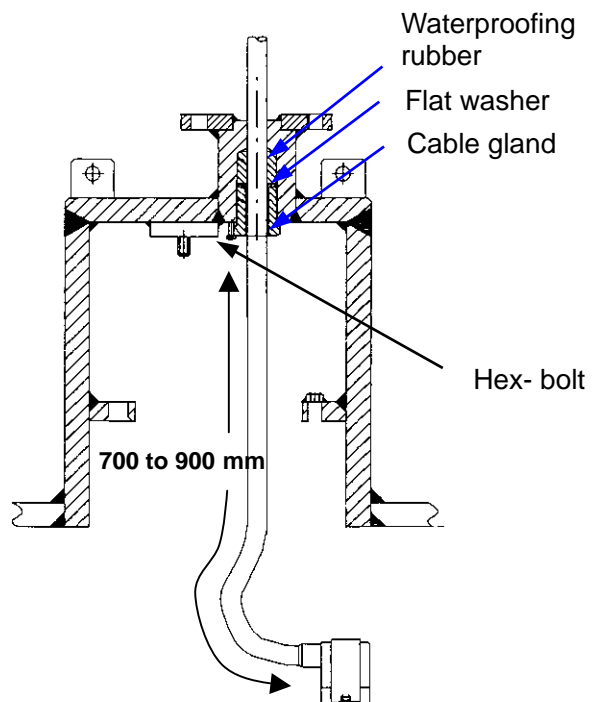

Fig. 12.2.4 Installing transducer cable

4. Connecting waterproof transducer connector



Fig. 12.2.5 Transducer, DS-330

- 1) Apply silicone grease (supplied in installation materials) on the connector face (whole area). Excess grease will isolate pin contacts.



Fig. 12.2.6 Waterproof connector

- 2) Plug the connector while holding up the connector ring.

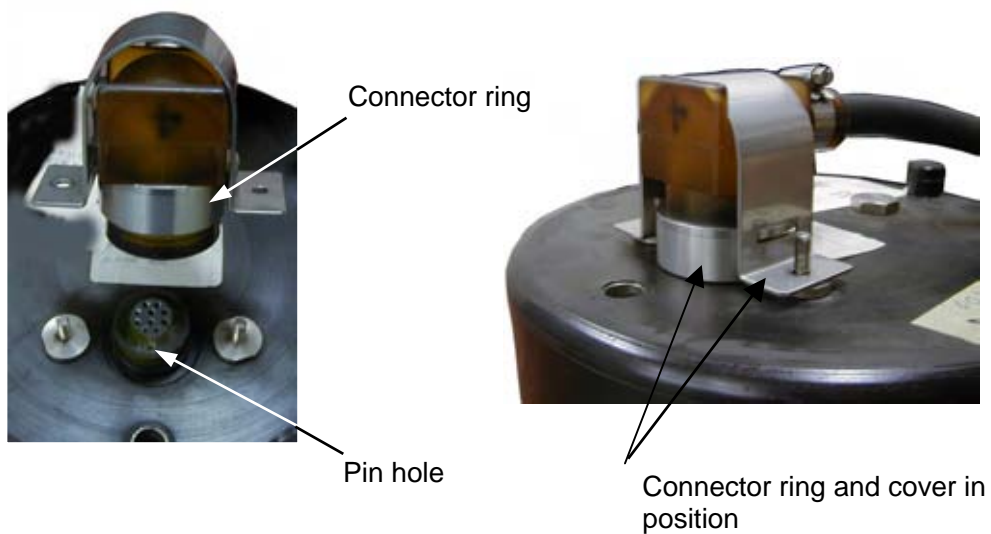

Fig. 12.2.7 Installing waterproof connector

- 3) Place the connector ring in position and fix the connector cover using the supplied flat washer, spring washer and nut.

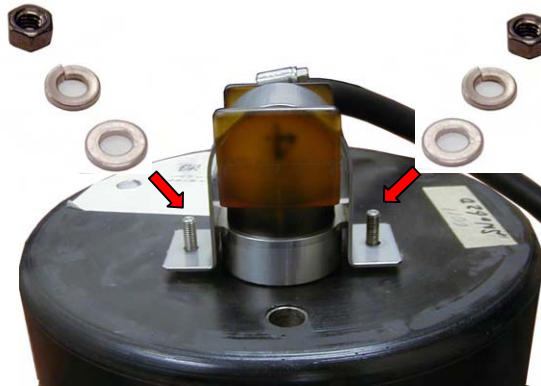

Fig. 12.2.8 Fixing waterproof connector

Use the titanium nuts and washers or equivalents to fix the connector cover. If not, the corrosion will be resulted.

5. Place the transducer with a correct alignment.

The protuberance on the DS-30 transducer should be in the stern direction. Fix the transducer with three bolts supplied.

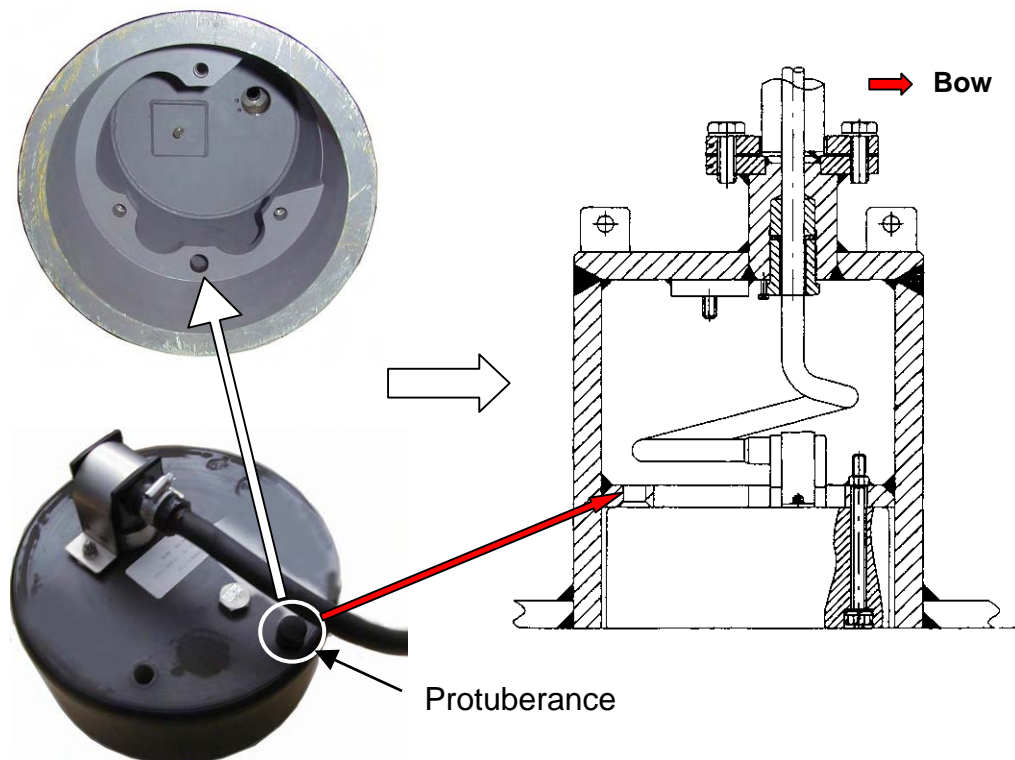
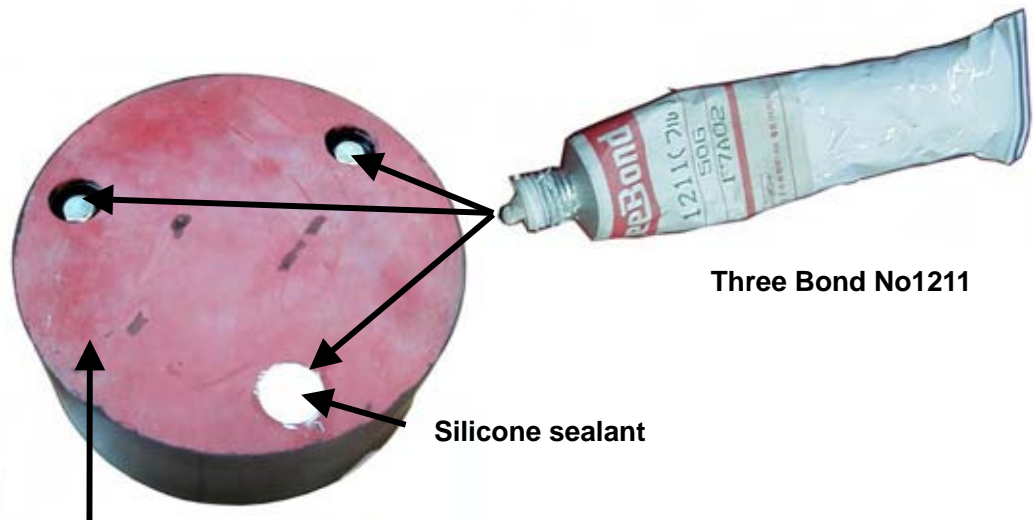

Fig. 12.2.9 Mounting transducer

6. After fixing the transducer, apply supplied silicone sealant on the head of three bolts.



The transducer face is coated with Marine-Star 20 in the factory. Recoating should be made only by Marine-Star 20.

Fig. 12.2.10 Applying silicone sealant

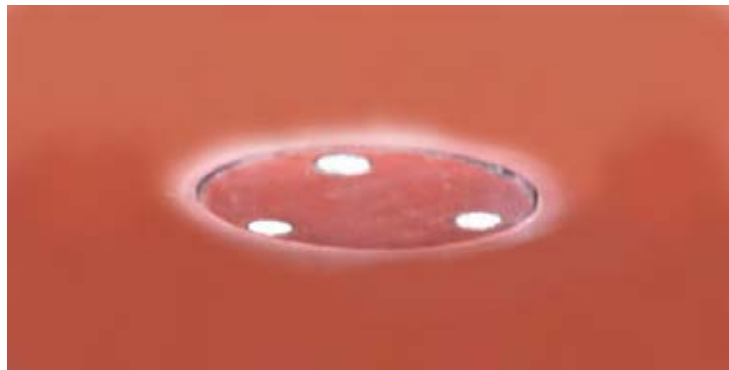

Fig. 12.2.11 Check hull bottom

Confirm that the transducer face is leveled to hull bottom plate, or projected a little (0.5 to 1 mm).

12.2.2 Gate-valve Tank

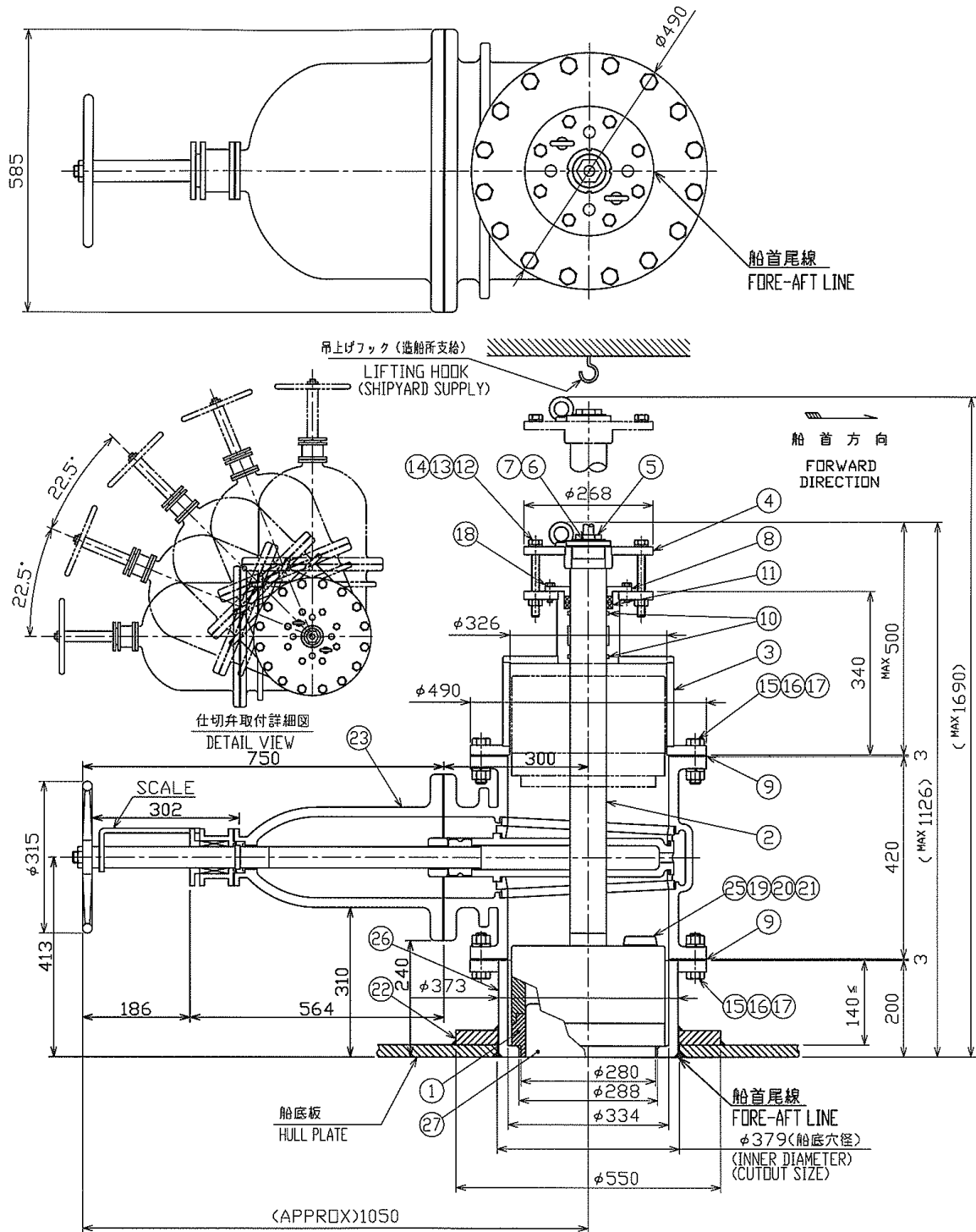

Fig. 12.2.12 Gate-valve DS-335

27	送受波器 TRANSDUCER		1	DS-330	
26	スペーサ SPACER	SM400/KSTPG410	1	66-019-1431	
25	防蝕塗料 ANTI-CORROSIVE ZINC		3	ZAP B-1 1/2	
24	ハンドル HANDLE	FC200	1		SHIPYARD SUPPLY
23	ゲートバルブ GATE VALVE	9.8 × 10 ⁵ Pa SC450	1	JIS F7366-350	SHIPYARD SUPPLY
22	船底補強板 DOUBLING PLATE	KA	1	66-019-1432	
21	座金 WASHER	SUS316L	3	M12	
20	バネ座金 SPRING WASHER	SUS316L	3	M12	
19	ボルト BOLT	SUS316L	3	M12 × 20	
18	ボルト BOLT	SUS316L	4	M10 × 35	
17	ナット NUT	SUS316L	32	M22	
16	バネ座金 SPRING WASHER	SUS316L	32	M22	
15	ボルト BOLT	SUS316L	32	M22 × 80	
14	ナット NUT	SUS316L	8	M16	
13	バネ座金 SPRING WASHER	SUS316L	8	M16	
12	ボルト BOLT	SUS316L	8	M16 × 150	
11	ブラインドシール BRIND SEAL		1 SET	VALQUA No. 7061	
10	Oリング O-RING	CR	2	JIS B2401 1A P75	
9	ガスケット GASKET	t=3mm NONASBESTOS JOINT SHEET	2	66-019-1404	NICHIASU No. 1995
8	固定金具 FIXING PLATE	SUS304	1	66-019-1407	
7	バネ座金 WASHER	SUS304	1	AW14	
6	ナット NUT	SUS304	1	AN14	
5	取付金具 FIXING GRAND	SUS316	1	66-019-1204	
4	押さえ板 UPPER PLATE	SS400	1	66-019-1403	
3	蓋 SEACHEST CAP	SM400/KSTPG370	1	66-019-1402	
2	シャフト SHAFT	SUS316L	1	66-019-1433	
1	ヘッドキャップ HEAD CAP	SUS316L	1	66-019-1434	
品番 ITEM	品名 NAME	材質 MATERIAL	数量 Q'TY	図番 DWG. No.	補要 REMARKS

1. Installing Spacer Tank

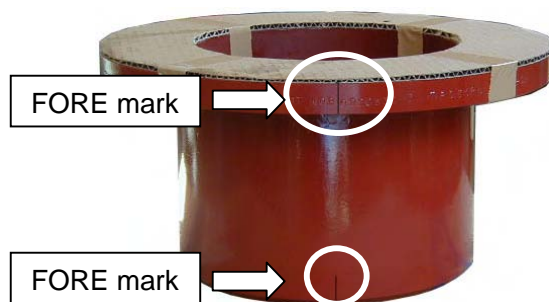
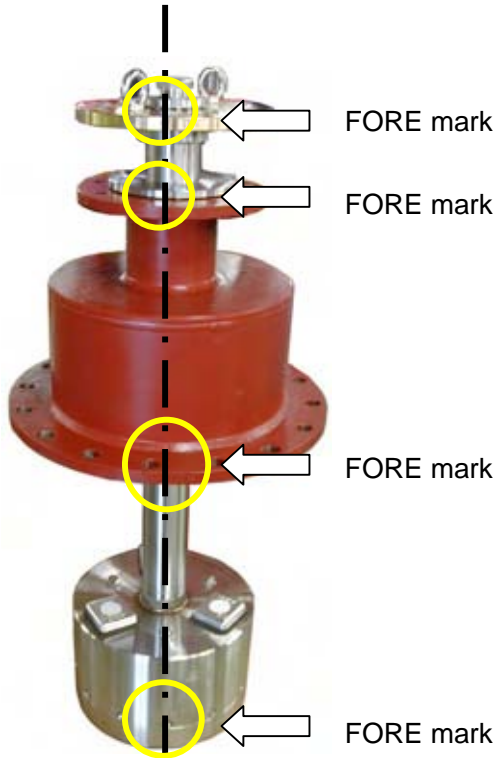

Fig. 12.2.13 FORE mark of spacer

- Align "FORE" mark of the tank to ship's bow direction.
(Accuracy must be within 1 degree.)
- The tank is mounted at right angles to the draft line.
- Never cut the tank.

2. Orienting "FORE" marks of gate-valve assembly



Fix shaft plate to shaft flange by 8 bolts supplied, after oriented the "FORE" marks.



3. Fixing transducer

Remove these three bolts and fix the transducer by bolts supplied.

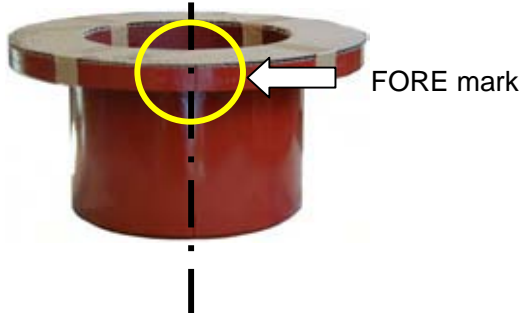
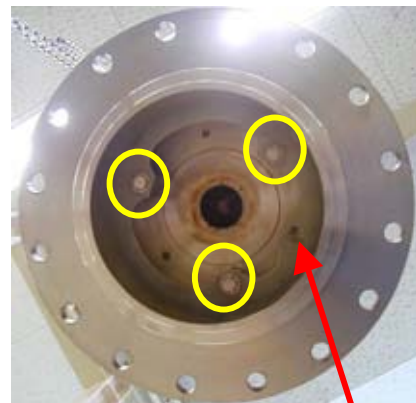

All "FORE" marks must be on one vertical line

This hole is for the protuberance (stern direction) of the transducer.

12.3 Installation of DS-50 transducer

12.3.1 Hull tank

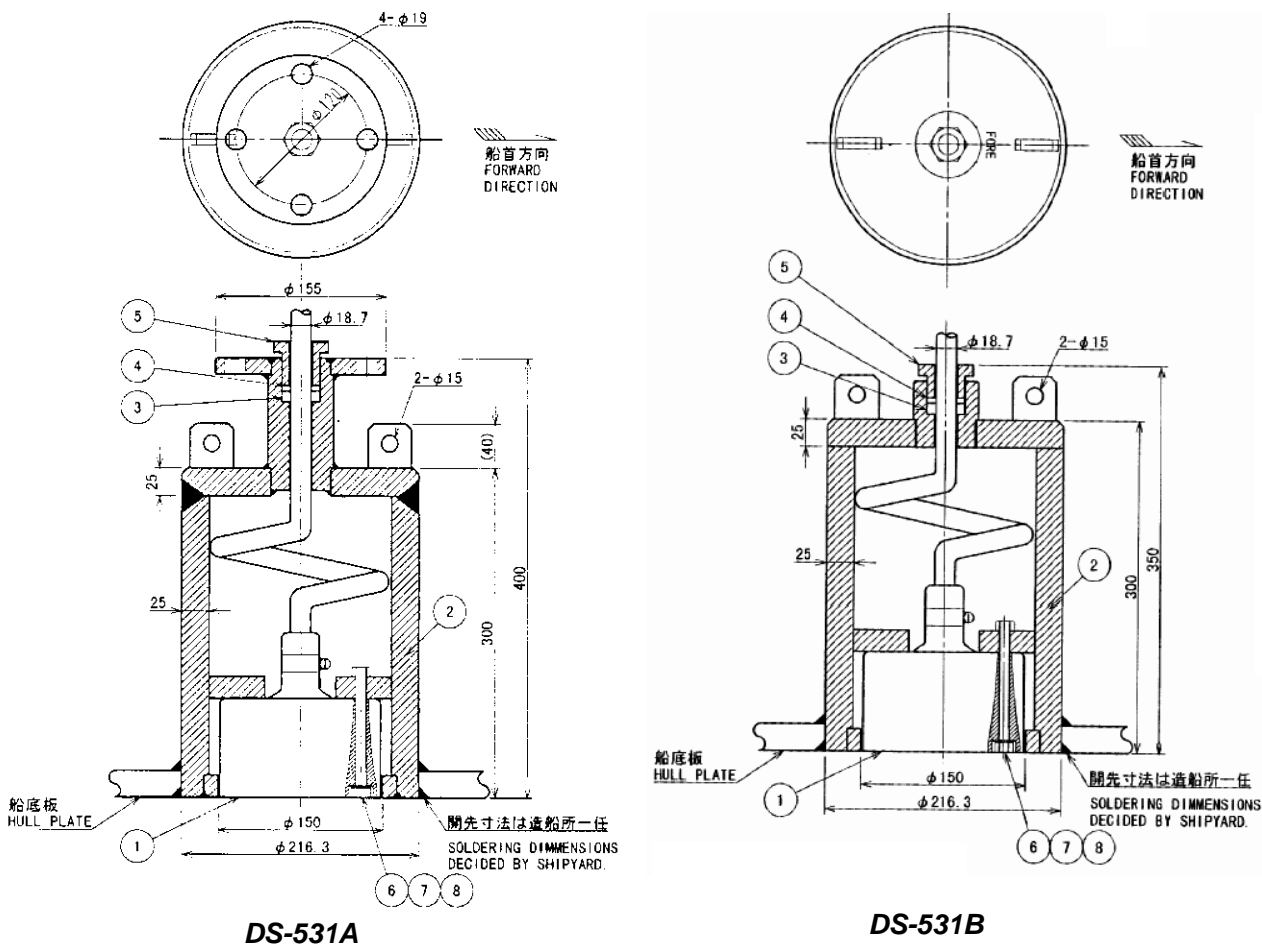

8	平座金 FLAT WASHER	M10	SUS304	3	
7	バネ座金 SPRING WASHER	M10	SUS304	3	
6	六角ボルト HEX. BOLT	M10×110	SUS304	3	
5	締付グラウンド CABLE GRIND		SUS304	1	66-017-1404
4	座金 WASHER		SUS304	1	66-017-1402
3	VAパッキン RUBBER GASKET		CR	1	VA-25
2	船底タンク CASTING		KSTP6370	1	66-022-7001
1	送受波器 TRANSDUCER			1	DS-530
品番 ITEM	品名 NAME	規格 SPEC.	材質 MATERIAL	数量 QTY	図番 DWG. NO.

Fig. 12.3.1 DS-50 Hull tank DS-531A/531B

1. Bow mark

The mark on the tank points toward the FORE direction. Alignment error is within 1 degree. The tank is mounted at the right angle of the draft line.

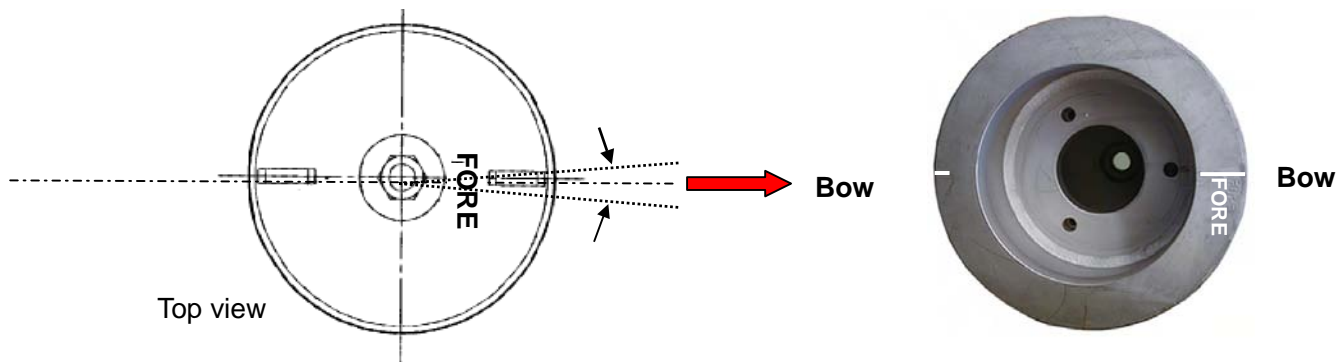

Fig. 12.3.2 DS-50 Hull tank

2. Mounting transducer

Transducer is also mounted with the correct alignment.

The fixing hole, which is closest to the edge, locates in the fore direction. If the transducer is inserted into the tank in wrong direction, it cannot be fixed. See Fig. 12.3.3.

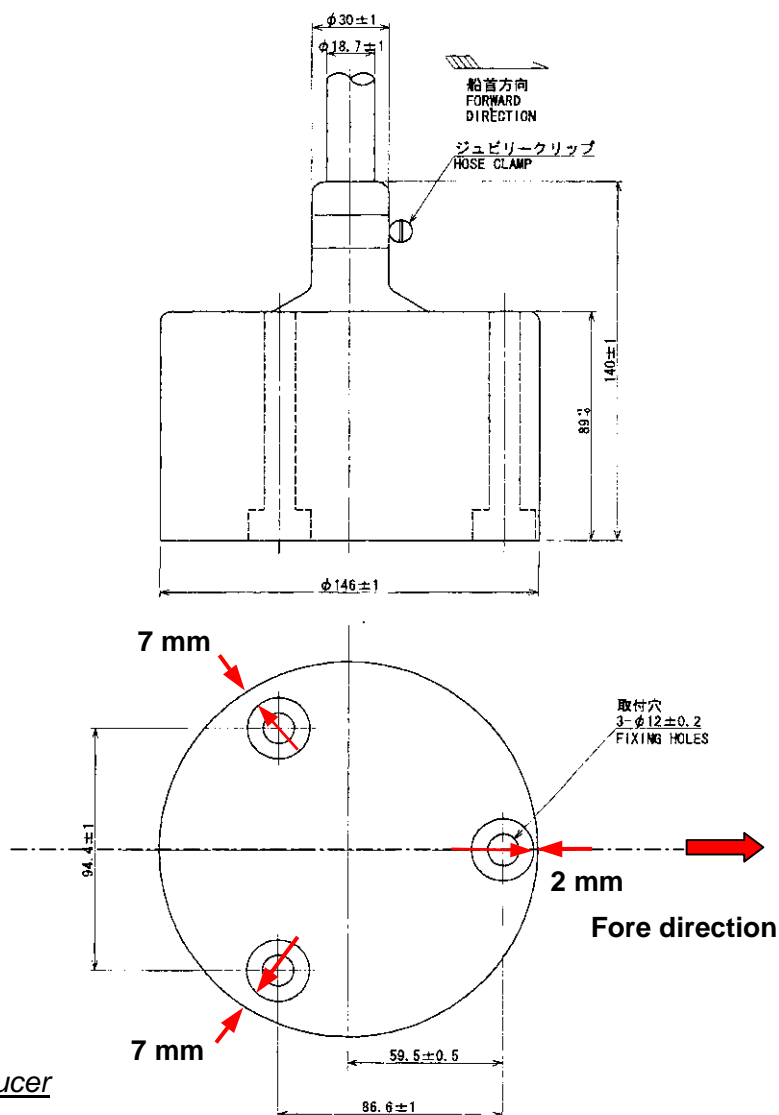

Fig. 12.3.3 Heading of Transducer

After mounting the transducer, apply supplied silicone sealant on the head of three bolts.

The transducer face is coated with Marine-Star 20 in the factory. Coating is not necessary at installation. For maintenance, use Marine-Star 20 only.

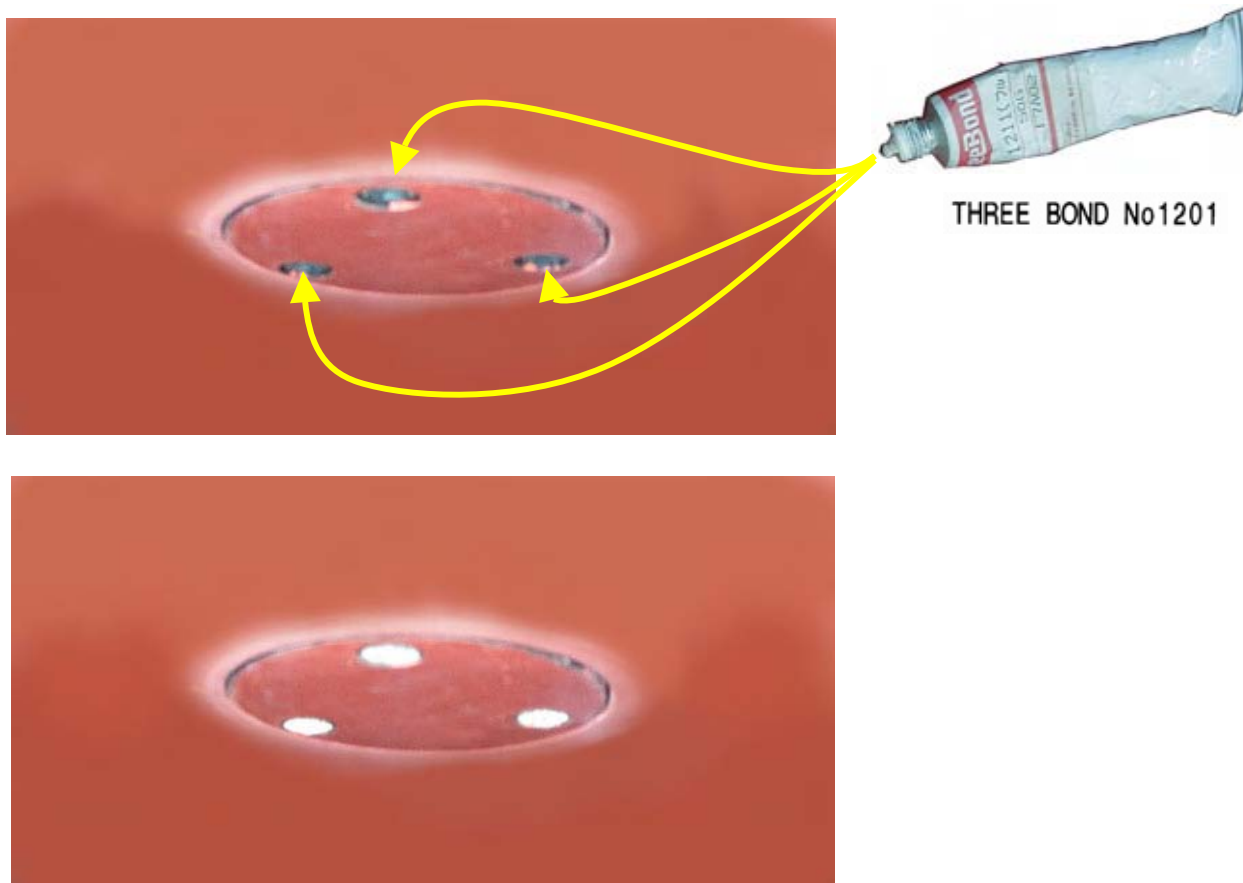

Fig. 12.3.4 Applying silicone sealant

Confirm that the transducer face is leveled to hull bottom plate, or projected a little (0.5 to 1 mm). If the transducer face sinks from the hull bottom level, install the tank again.

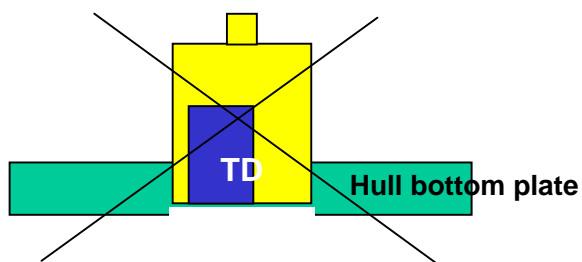

Fig. 12.3.5 Check level of transducer

12.3.2 Installing tank with Gate-valve

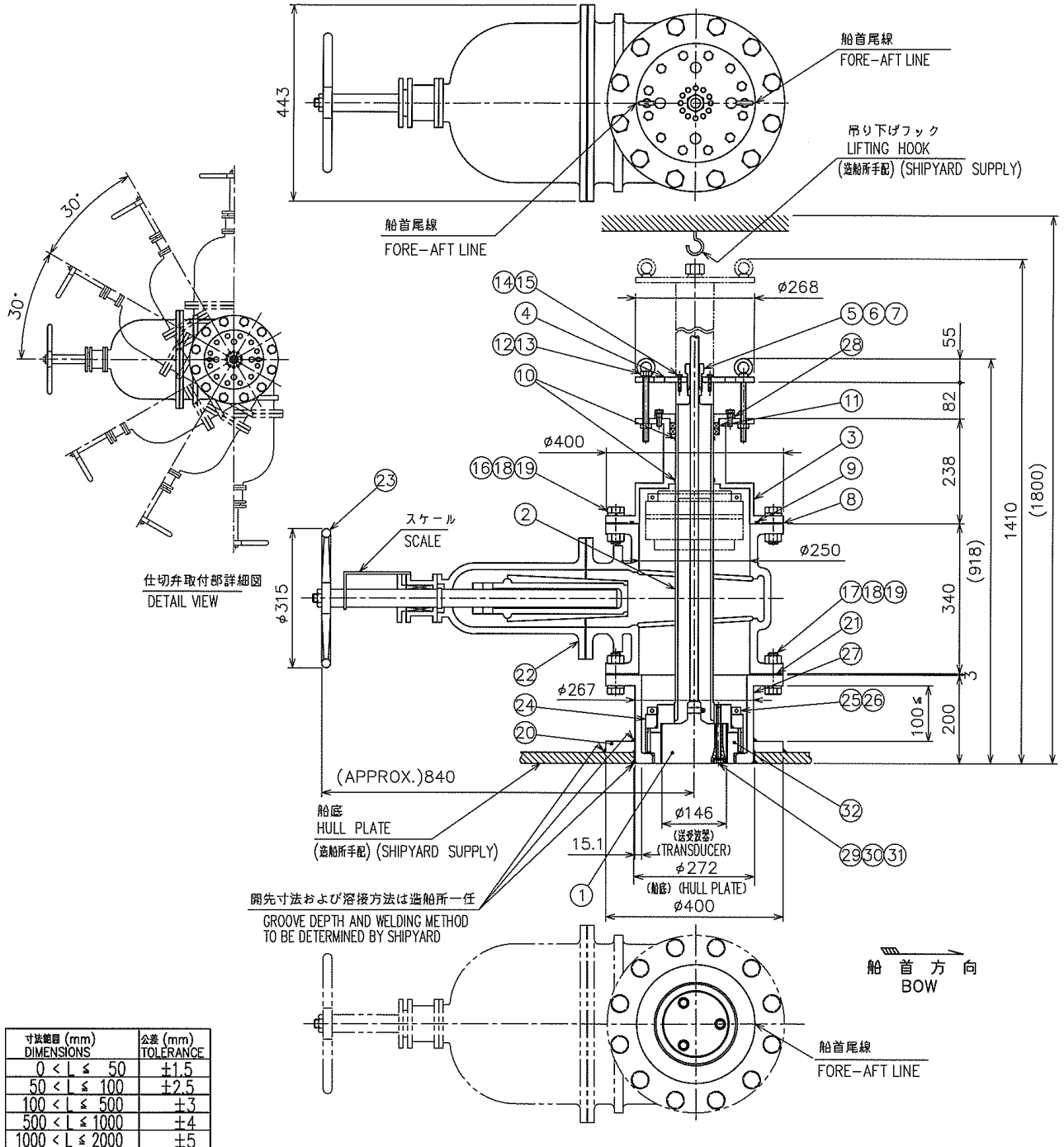

Fig. 12.3.6 DS-50 transducer: DS-530

32	ヘッドキャップ HEAD CAP		SUS316L	1	65-005-8104	
31	平座金 FLAT WASHER	M10	SUS316L	3		
30	バネ座金 SPRING WASHER	M10	SUS316L	3		
29	ボルト BOLT	M10×120	SUS316L	3		
28	コットン押さえ COTTON CONTROL		SUS316L	1	65-002-1011	
27	隙上げタンク SPACER LACQUER PRIMER		KSTPG370	1	65-005-8101	船級認定材 CLASSIFICATION SOCIETY APPROVED MATERIAL
26	締め止めバンド CLAMP BAND		SUS316L	2	65-002-1021	
25	締め止め器具 CLAMP PIN		SUS316L	2	65-002-1024	
24	防錆塗料 ANTI-CORROSIVE ZINC		ZAP	2	65-002-1022/28	
23	取手 HANDLE		FC20	1		
22	仕切り弁 GATE VALVE 9.8×10 ⁵ Pa ALKYD RESIN PRIMER		SC46	1	JIS F7366-250B	船級認定材 CLASSIFICATION SOCIETY APPROVED MATERIAL
21	パッキン GASKET		JOINT SHEET	1	65-002-1003	t=3mm
20	隙上げダブリング DOUBLING PLATE LACQUER PRIMER		KAS	1	65-005-8102	船級認定材 CLASSIFICATION SOCIETY APPROVED MATERIAL
19	ナット NUT	M22	SUS316L	24		
18	バネ座金 SPRING WASHER	M22	SUS316L	24		
17	ボルト BOLT	M22×80	SUS316L	12		
16	ボルト BOLT	M22×70	SUS316L	12		
15	バネ座金 SPRING WASHER	M6	SUS316L	12		
14	ボルト BOLT	M6×25	SUS316L	12		
13	バネ座金 SPRING WASHER	M12	SUS316L	12		
12	ボルト BOLT	M12×150	SUS316L	12		
11	グリスコットン GREASE COTTON				12.7 X 12.7	
10	Oリング O-RING		NBR	2	JIS B2401 G-85	
9	Oリング O-RING		NBR	1	JIS B2401 G-280	
8	パッキン GASKET		CR	1	65-002-1004	t=2mm
7	座金 WASHER		SUS316L	1	66-017-1405	
6	パッキン PACKING		CR	1	VA-25	
5	締め付けグラウンド FIXING GRND		SUS316L	1	66-022-8003	
4	アッパープレート UPPER PLATE LACQUER PRIMER		SS400	1	65-002-1009	
3	シーチェストキャップ SEACHEST CAP LACQUER PRIMER		KSTPG370	1	65-002-1005	船級認定材 CLASSIFICATION SOCIETY APPROVED MATERIAL
2	メインシャフト SHAFT		SUS316L	1	65-005-8105	
1	送受波器 TRANSDUCER			1		DS-530
品番 ITEM	品名 NAME		材質 MATERIAL	数量 Q.TY	図番 DWG.NO.	摘要 REMARKS

Fig. 12.3.7 Transducer tank with Gate-valve: DS-532

1. Bow mark on the flange must be located in fore direction.

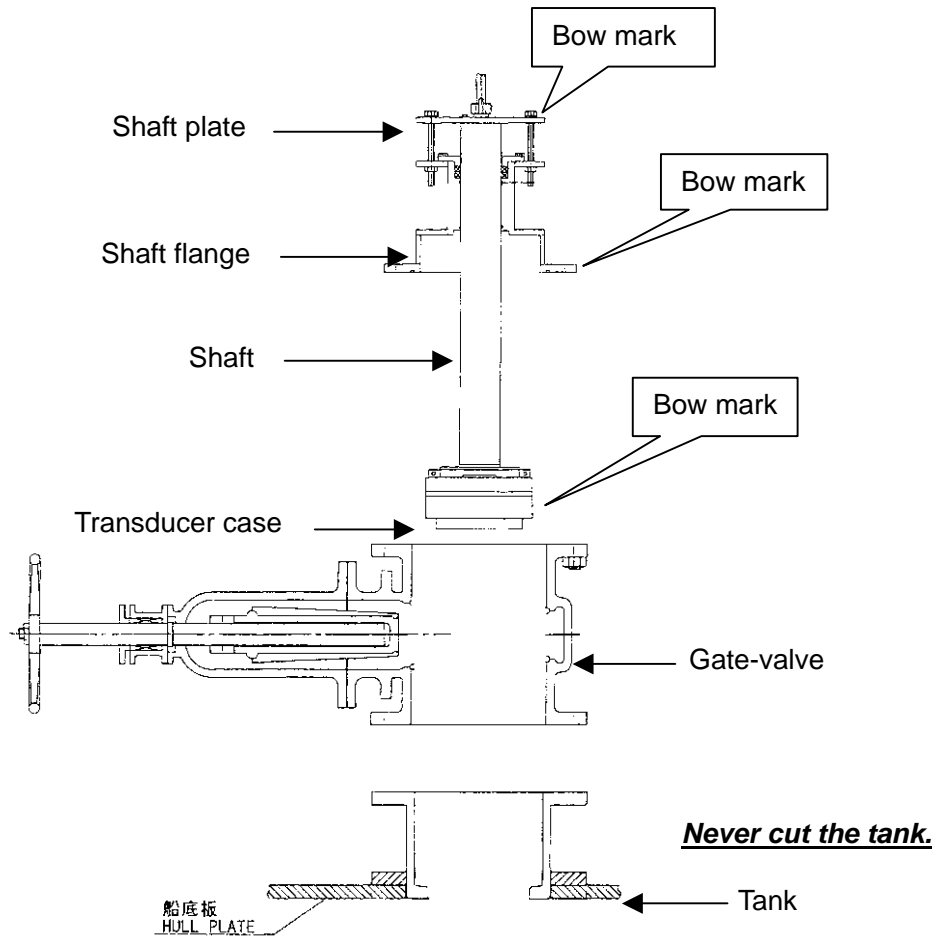

Fig. 12.3.8 Transducer tank with Gate-valve, exploded

2. Installing tank

The centerline between the fixing holes is the fore-aft line.

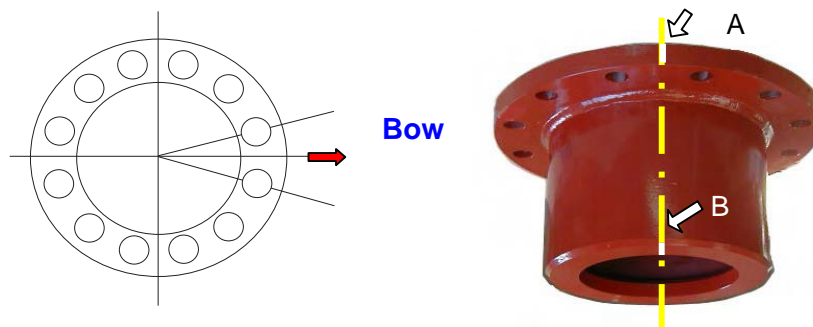

Fig. 12.3.9 Bow direction of tank

3. Before mounting tank

Put the A and B bow-mark on the tank as shown in the Fig. 12.3.9. (Accuracy: within 1 degree) The tank is mounted at right angles to the draft line.

4. Installing transducer

Insert the transducer into the case. The transducer-fixing hole, which is closest to the edge, matches to the fore mark on the case. The transducer is fixed with three bolts supplied.

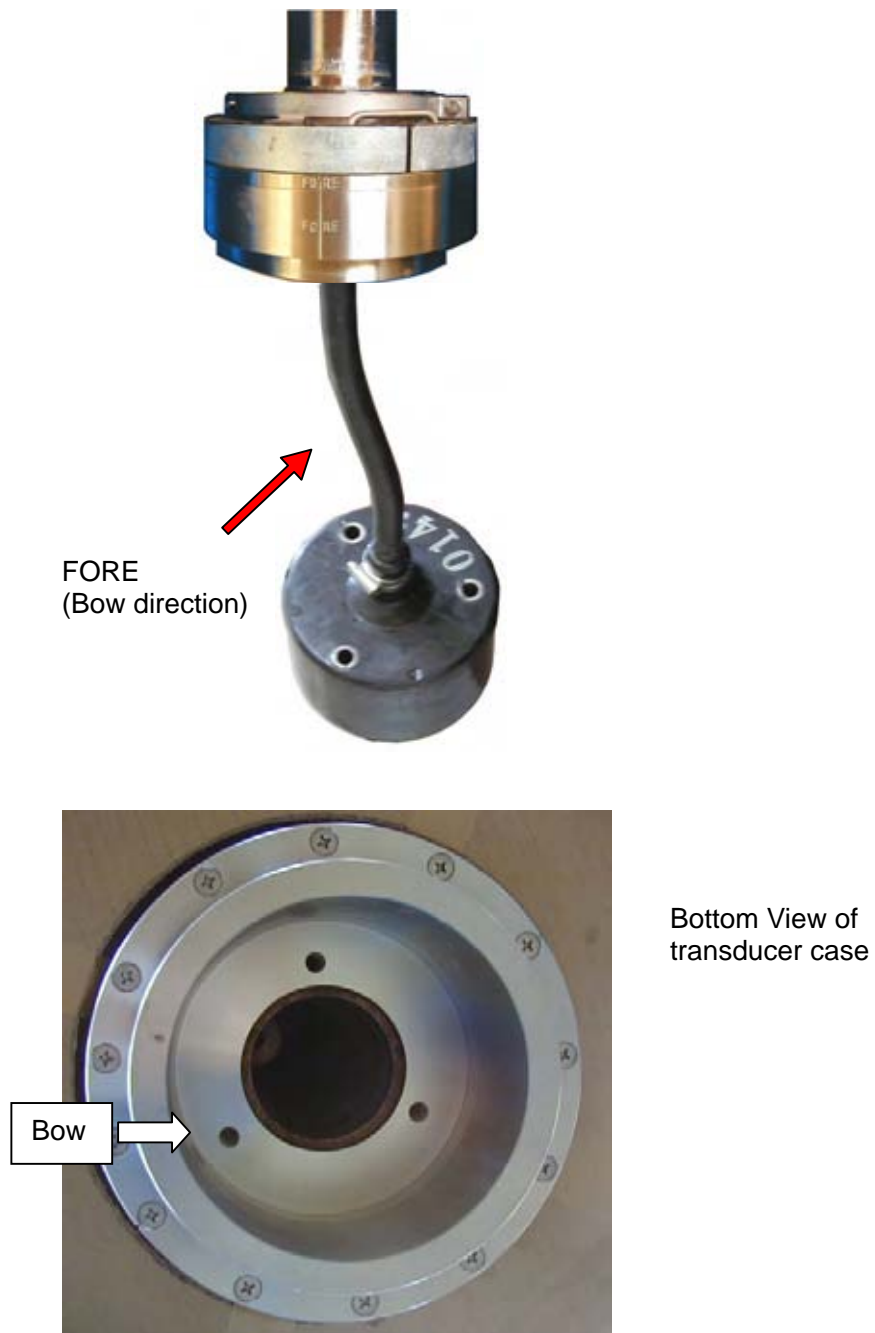

Fig. 12.3.10 Mounting transducer

5. Caution on mounting shaft / transducer assembly to Gate-valve

"FORE" marks must be in the bow direction.

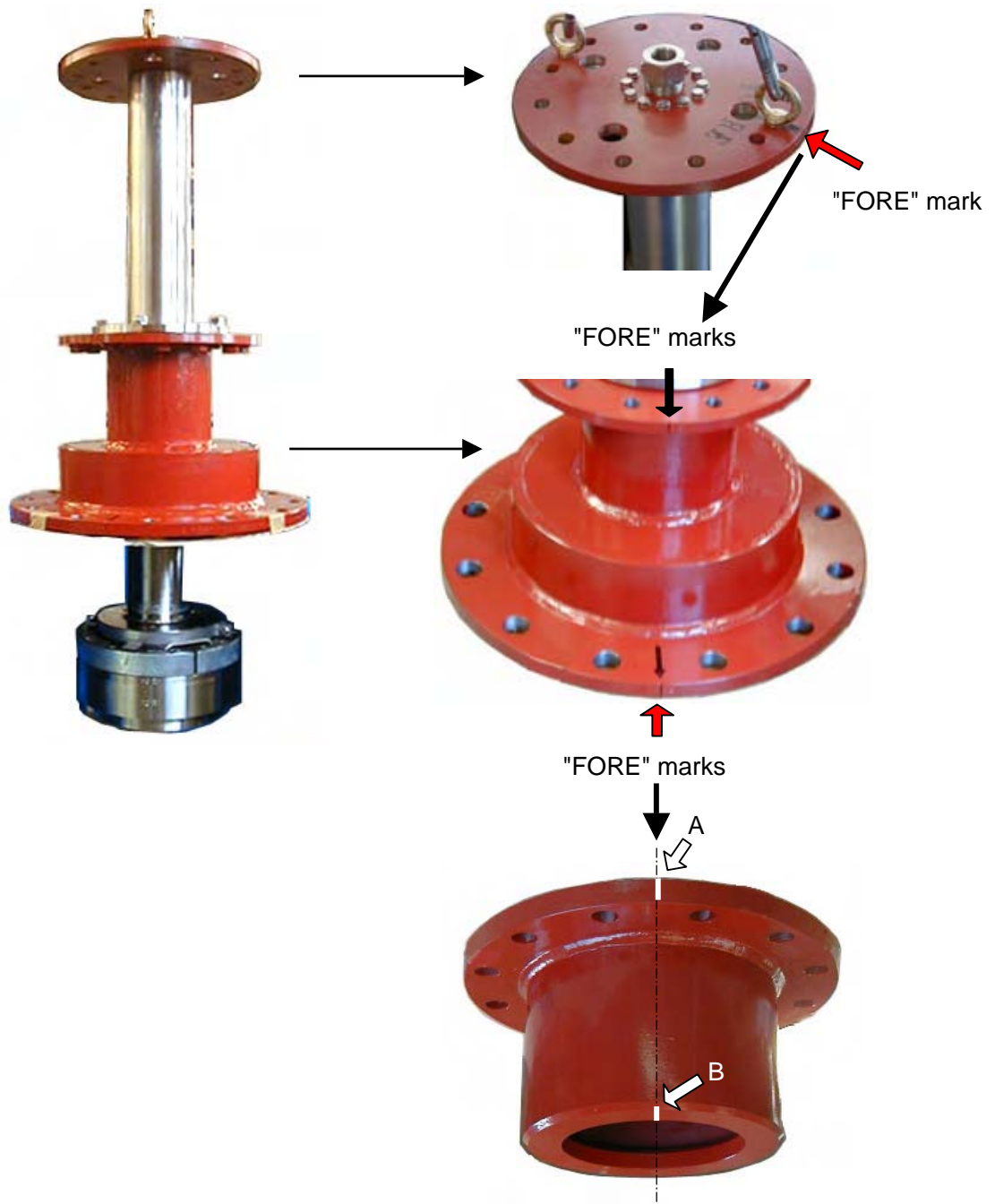

Fig. 12.3.11 Orienting "FORE" marks

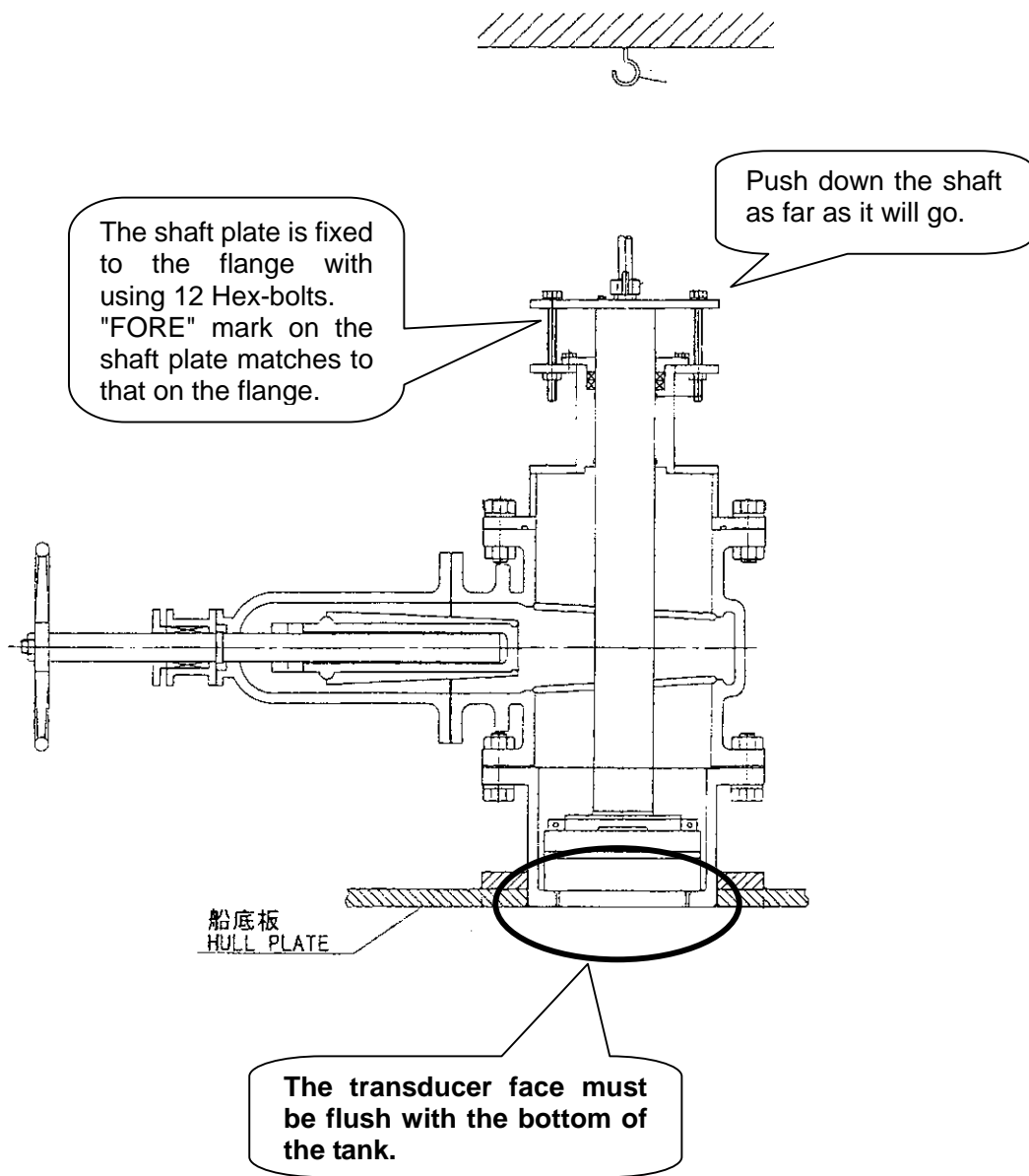

Fig. 12.3.12 Mounting transducer

1. Weld the hull flange (3) to the hull bottom with the FORE mark pointing toward the bow direction and reference marks on the side of the hull flange aligned with the fore-aft line.

- Fore-aft alignment is accurate within ± 1 degree.
- The flange must be parallel to the draft line within ± 1 degree.
- Grind the welding area outside the hull bottom to accomplish flatness.

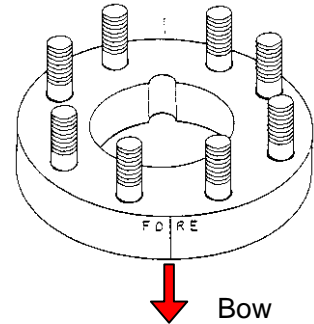

Fig. 12.4.2 Bottom flange

2. Apply KINORUSTER or alternative anticorrosive sealant to the flanges and the gasket as shown in Fig. 12.4.3. Use the sealant for both side of the gasket.

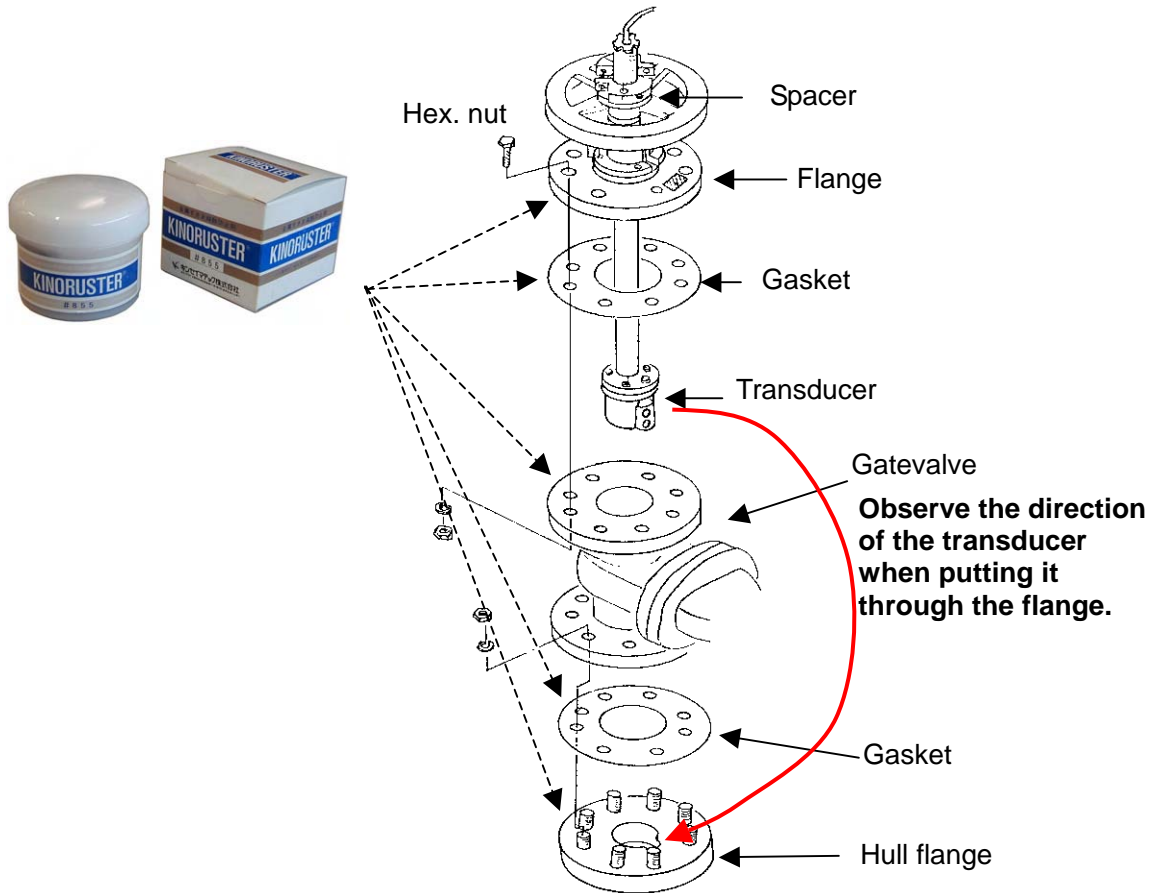

Fig. 12.4.3 Gate-valve DS-782, enlarged

3. Mounting transducer

Insert the transducer into the head cap so that the protuberance of the transducer engages to location mark. Then, fix the transducer to the head cap with the Hex-bolts.

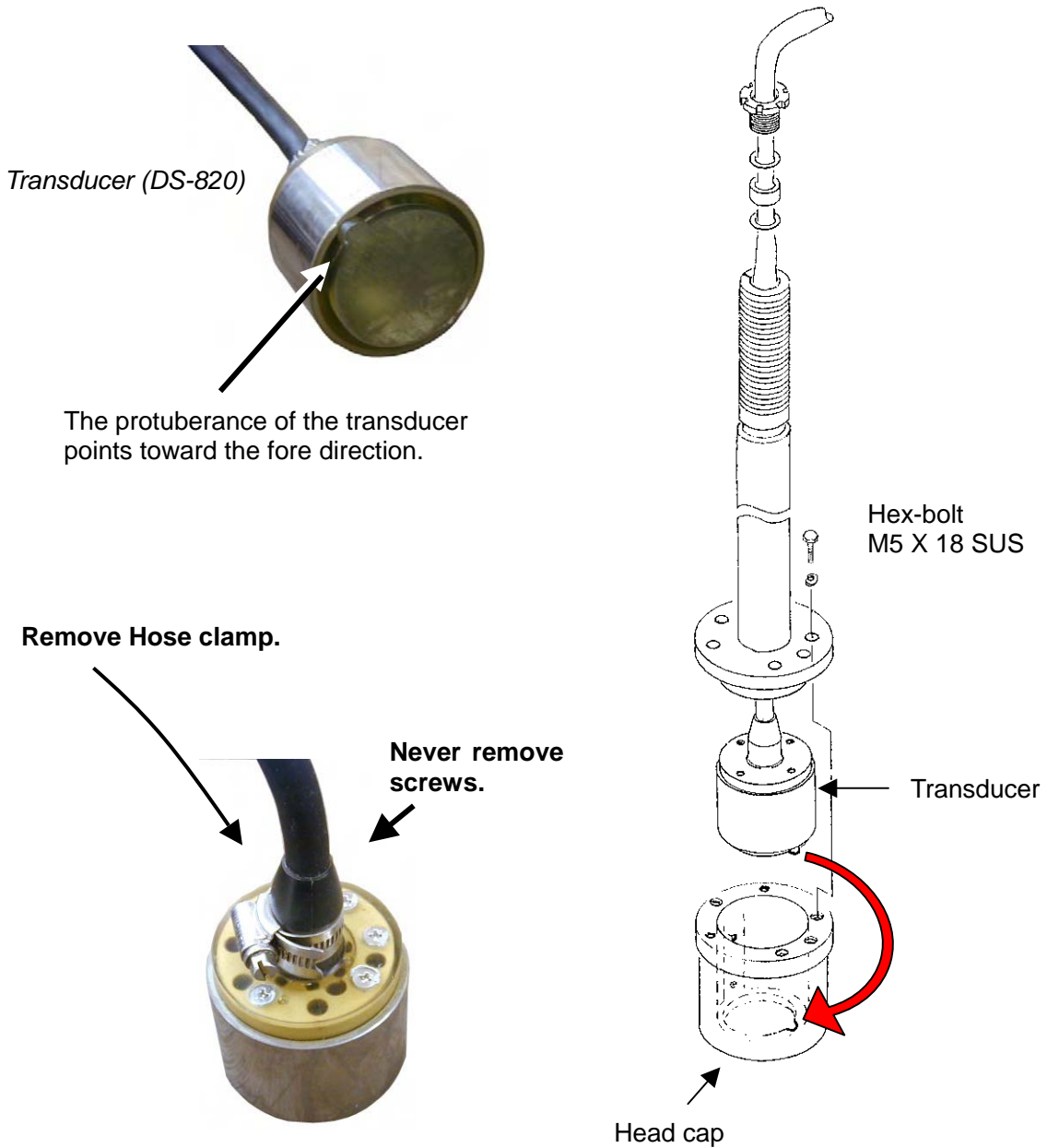
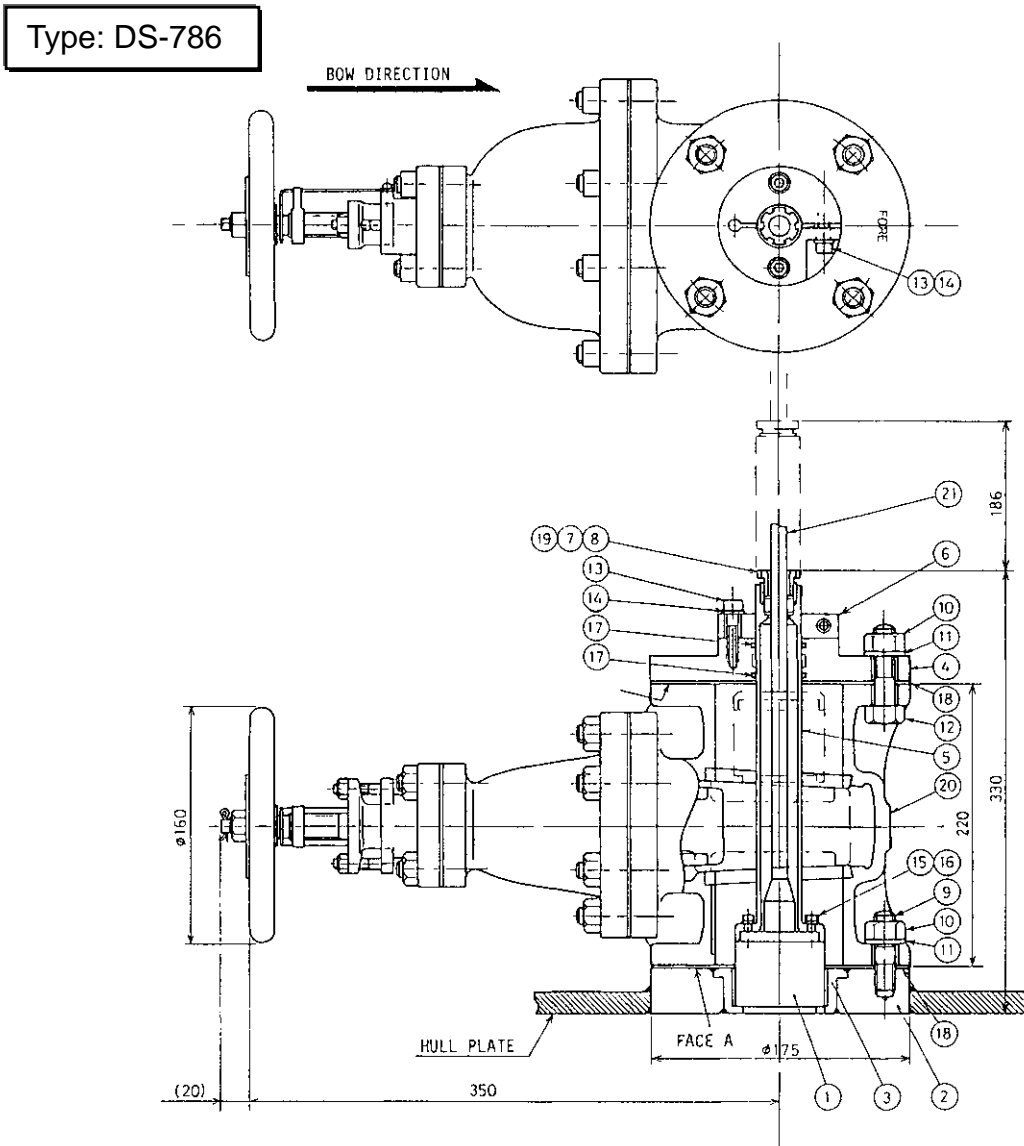

Fig. 12.4.4 Mounting of transducer

12.4.2 Gate-valve tank: DS-786



No.		QTY.	No.		QTY.
1	TRANSDUCER	1	12	HEX.BOLT	4
2	HULL FLANGE	1	13	HEX. SOCKET HEAD BOLT	3
3	BUSHING		14	SPRING WASHER	3
4	FLANGE	1	15	HEX. SOCKET HEAD BOLT	4
5	SHAFT	1	16	SEAL WASHER	4
6	LOCK RING	1	17	O RING	2
7	GASKET	1	18	GASKET	2
8	WASHER	2	19	FIXING GLAND	1
9	TAP-END STUD BOLT	4	20	GATE VALVE	1
10	HEX. NUT	8	21	CONNECTION CABLE	
11	SPRING WASHER	8			

Fig. 12.4.5 DS-80 Gate-valve hull tank: DS-786

1. Mounting of transducer

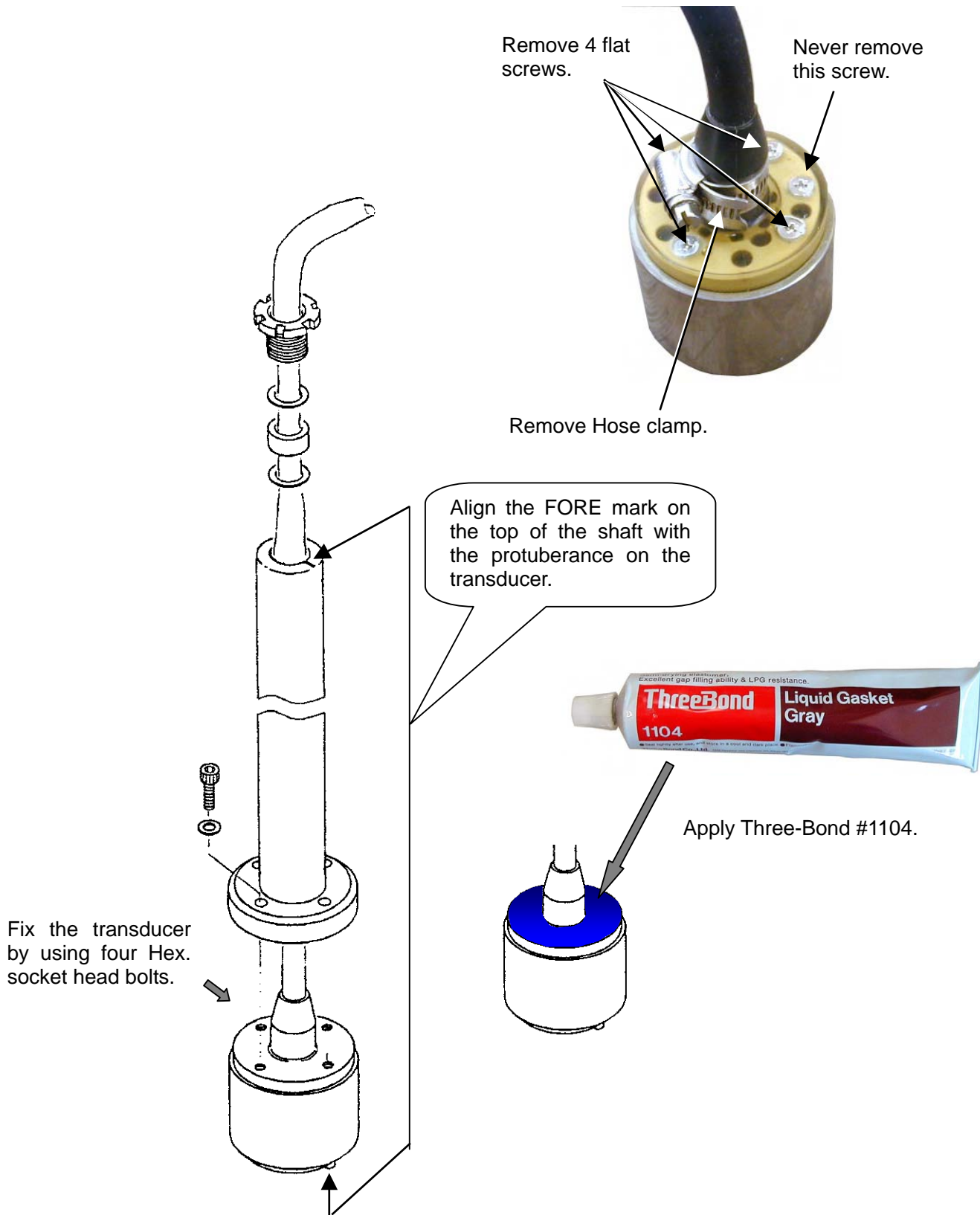

Fig. 12.4.6 Mounting DS-80 transducer

2. Weld the hull flange with FORE mark aligned to the bow direction and the reference marks to the fore-aft line.

- Fore-aft alignment is accurate within ± 1 degree.
- The flange must be parallel to the draft line within ± 1 degree.
- Grind the welding area outside the hull bottom to accomplish flatness.

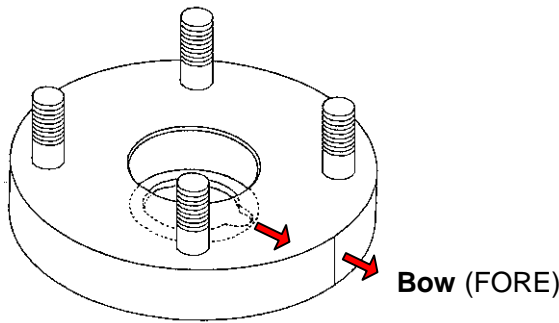

Fig.12.4.7 Mounting bottom flange

Apply KINORUSTER or alternative anticorrosive sealant to the flanges and the gasket as shown in Fig. 12.4.8. Use the sealant for both side of the gasket.



Align FORE mark on the flange with that on the bottom flange.

Align FORE mark on the top of the shaft with that on the flange.

Confirm that the transducer face flushes with the hull bottom.

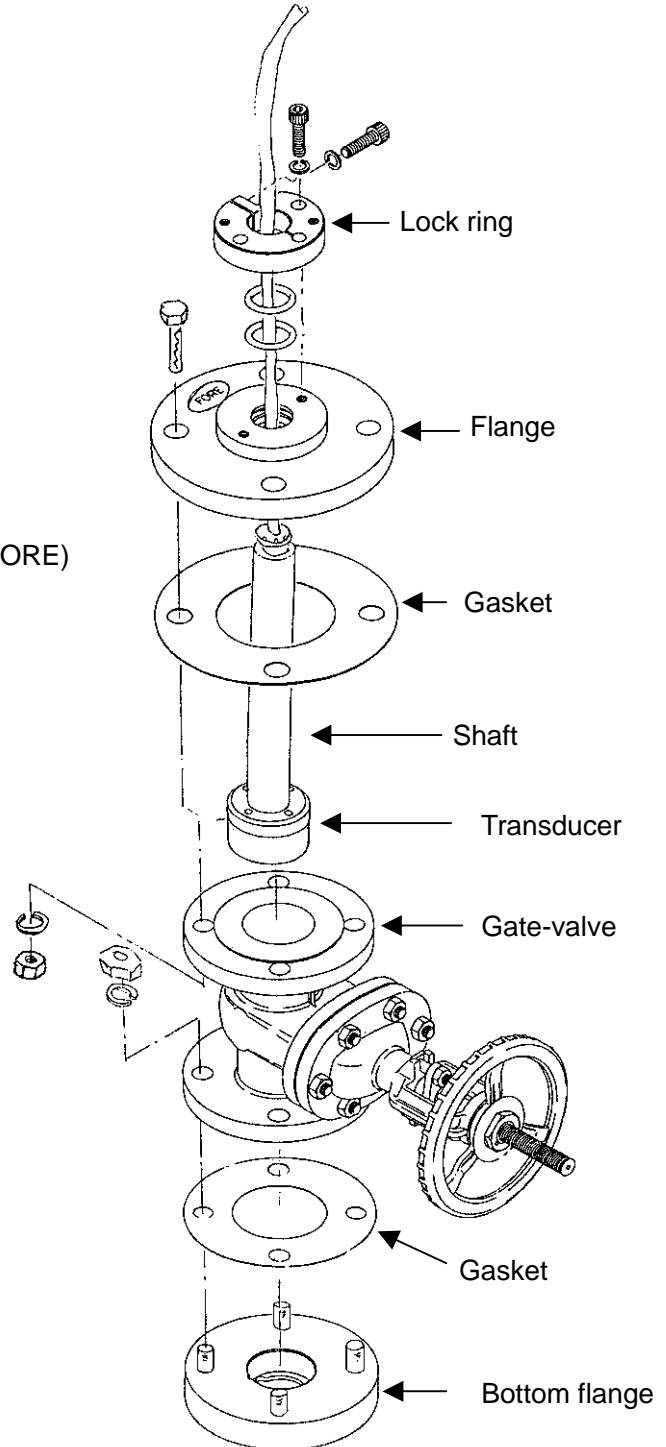
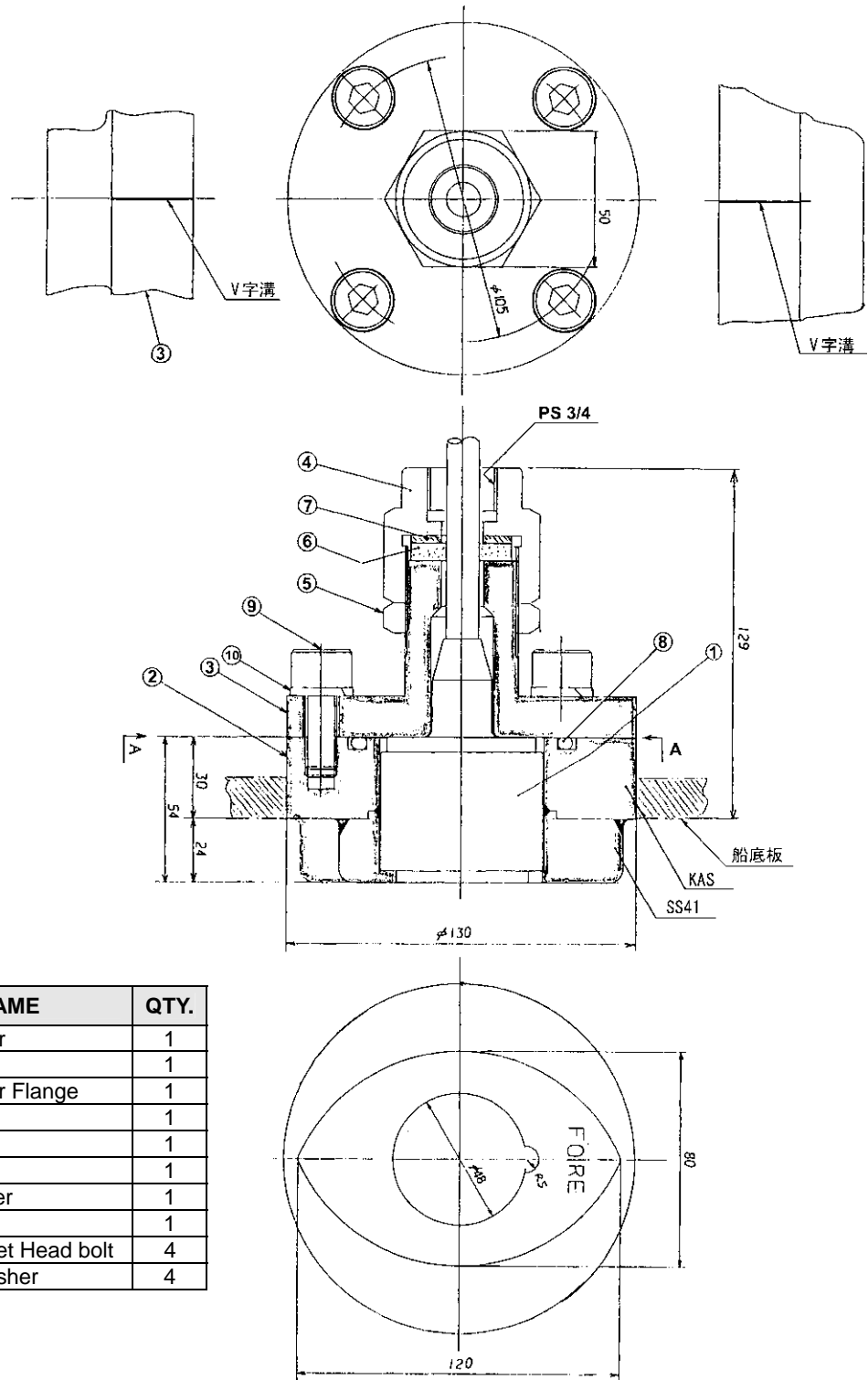

Fig. 12.4.8 DS-786, enlarged

12.4.3 Hull tank: DS-783

Note:

Before welding the hull flange, remove the O-ring, transducer and transducer flange.



No.	NAME	QTY.
1	Transducer	1
2	Flange	1
3	Transducer Flange	1
4	CAP NUT	1
5	Nut	1
6	Gasket	1
7	Flat Washer	1
8	O-Ring	1
9	Hex. Socket Head bolt	4
10	Spring Washer	4

Fig. 12.4.9 Hull tank: DS-783

12.4.4 Hull Tank: DS-784

Note:

Before welding the hull flange, remove the O-ring, transducer and transducer flange.

No.	NAME	QTY.
1	Transducer	1
2	Flange	1
3	Transducer Flange	1
4	CAP NUT	1
5	Nut	1
6	Gasket	1
7	Flat Washer	1
8	O-Ring	1
9	Hex. Socket Head bolt	4
10	Spring Washer	4

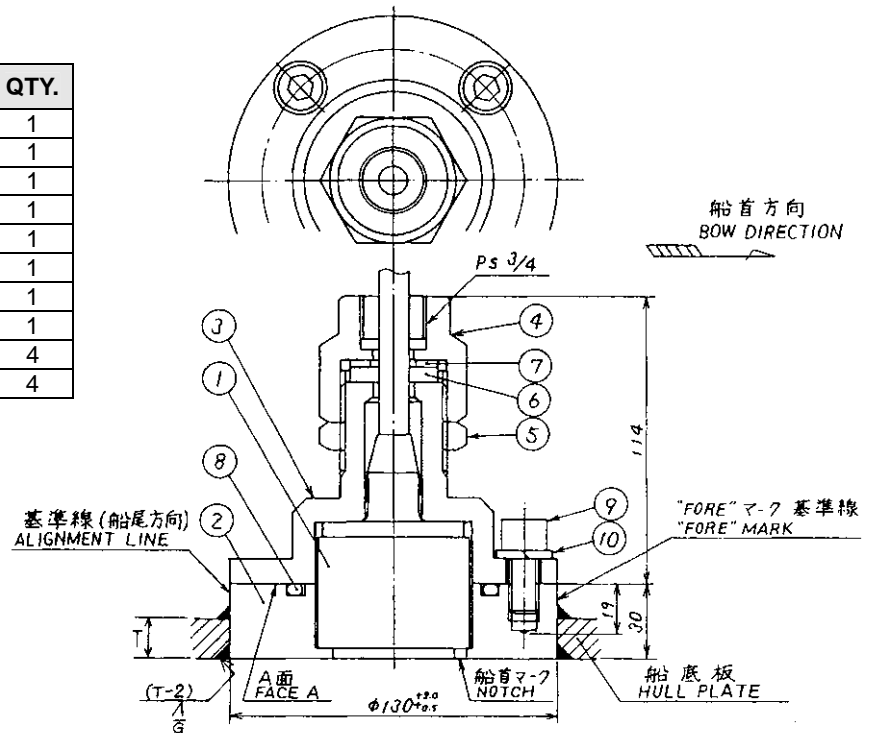

Fig. 12.4.10 Hull tank: DS-784

Apply KINORUSTER or alternative anticorrosive sealant to the O-ring groove, O-ring, transducer flange and Hex. nut.



Engage the protuberance of the transducer to the slot of the hull flange.

FORE mark on the bottom points toward the fore direction. Weld the flange with reference marks aligned to the fore-aft line. (Accuracy: within 1 degree)

The flange must be parallel to the draft line within ± 1 degree. Grind the welding area outside the hull bottom to accomplish flatness.

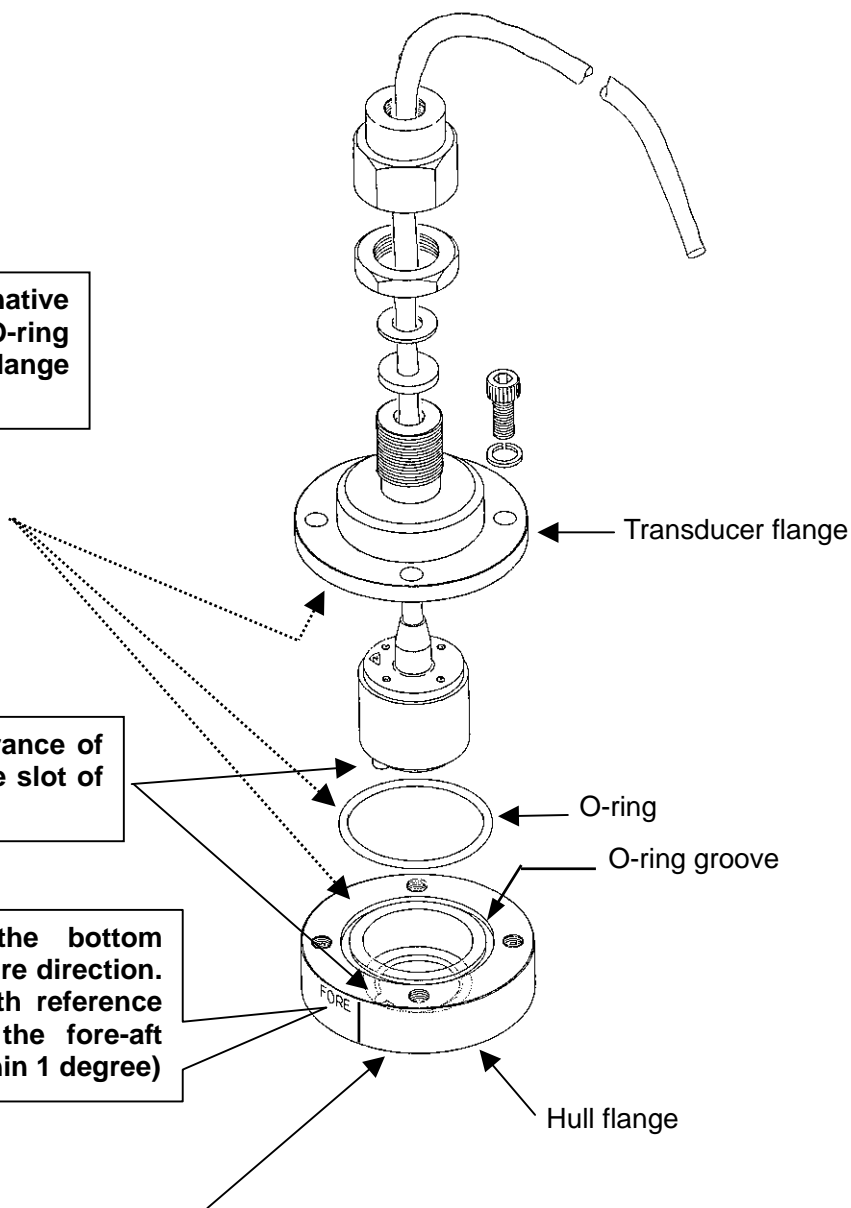

Fig. 12.4.11 DS-784 enlarged

12.4.5 Protruded hull tank

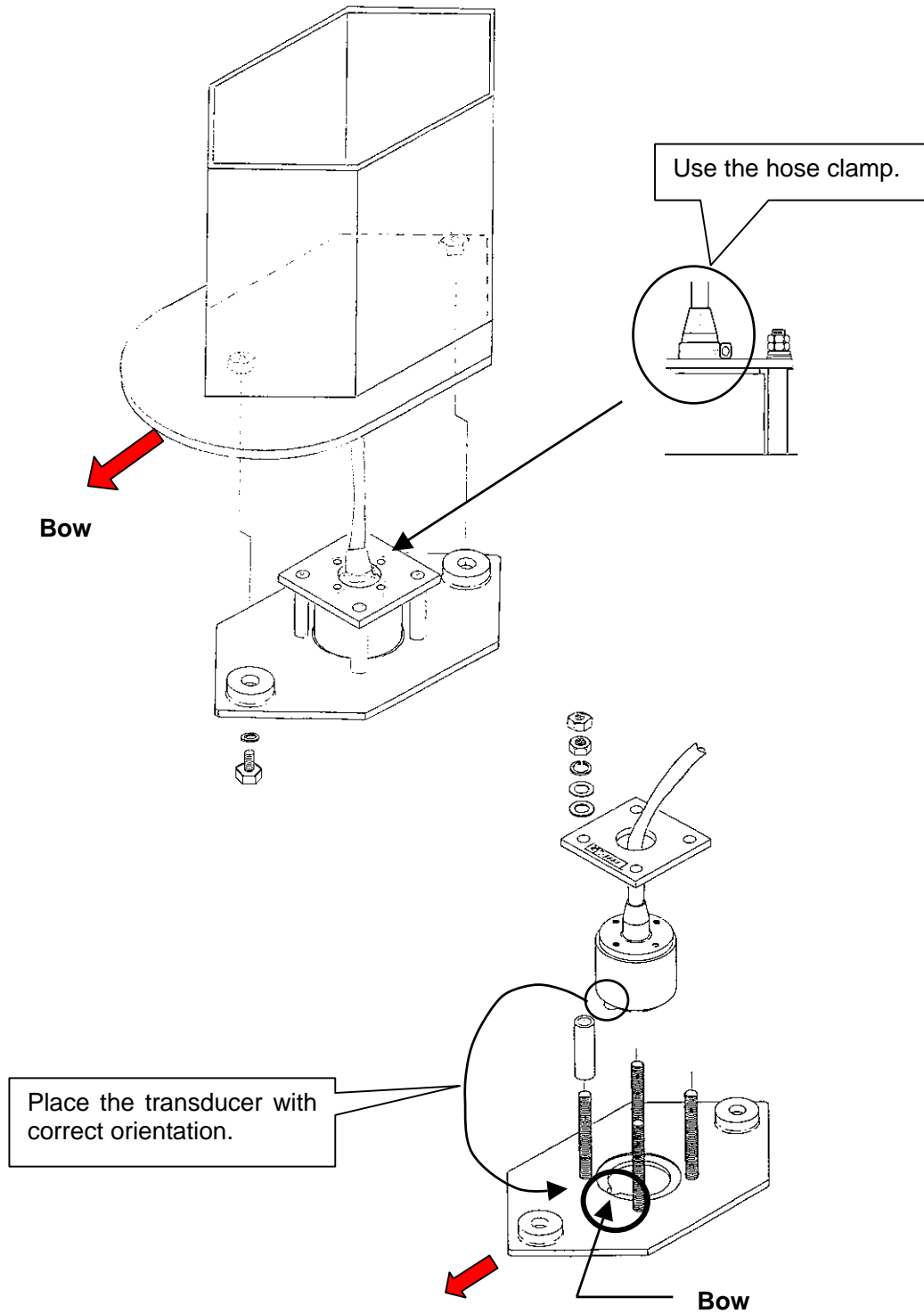

Fig. 12.4.12 Mounting DS-781

12.5 Example of installations

12.5.1 Example of DS-50 installation

1. Gate-valve: DS-532

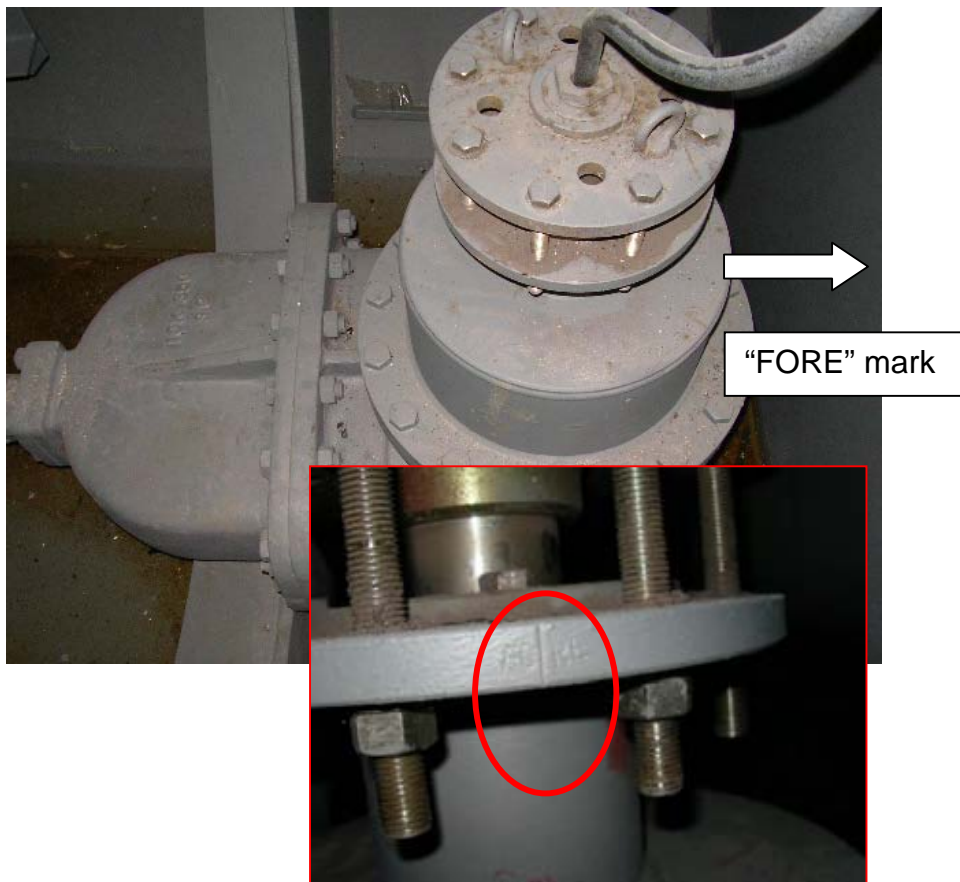

Fig. 12.5.1 Gate-valve

2. DS-50 Main display unit (DS-500)

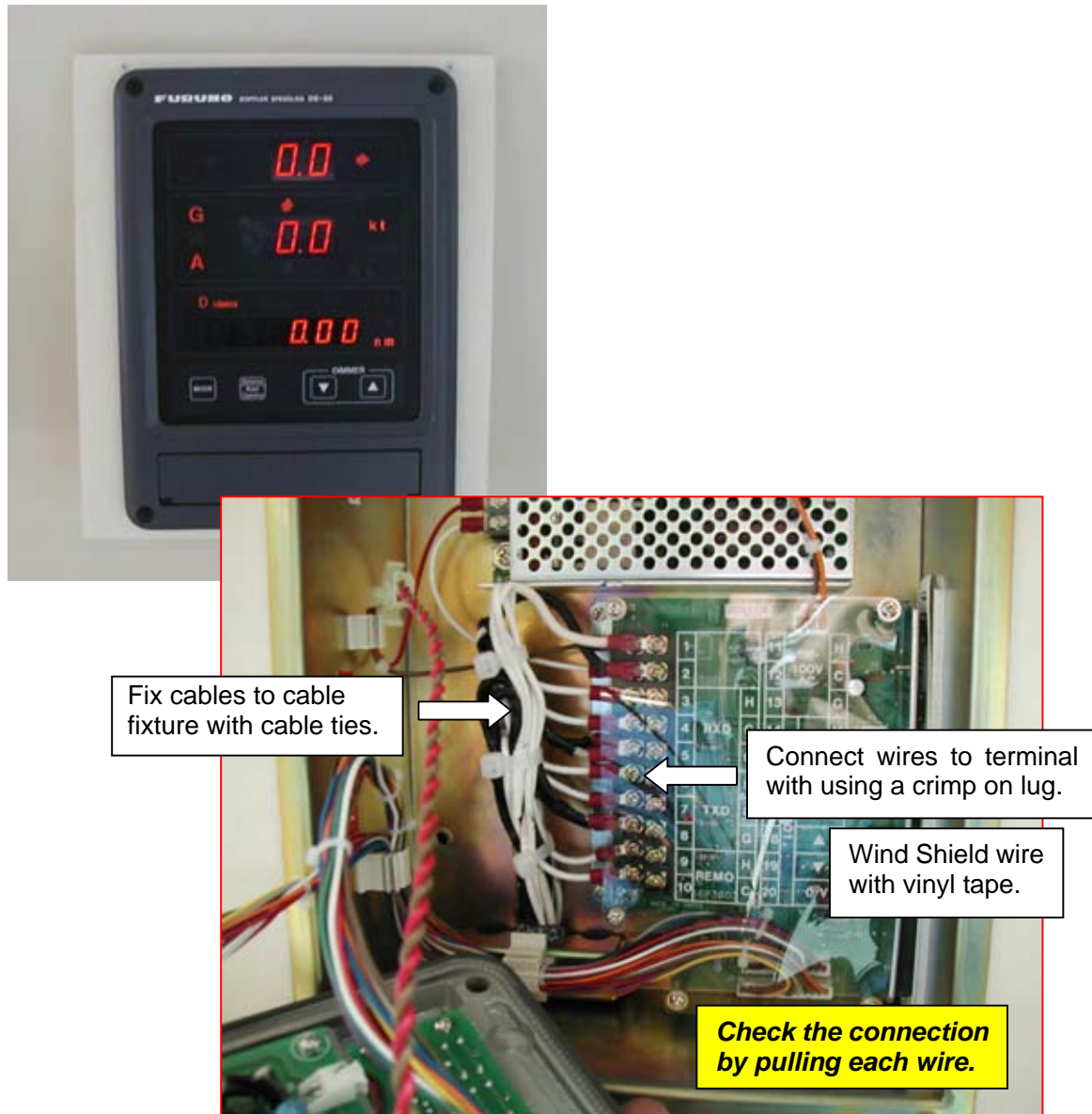

Fig. 12.5.2 DS-50 Main display unit (DS-500)

3. DS-50 Processor unit (DS-511)

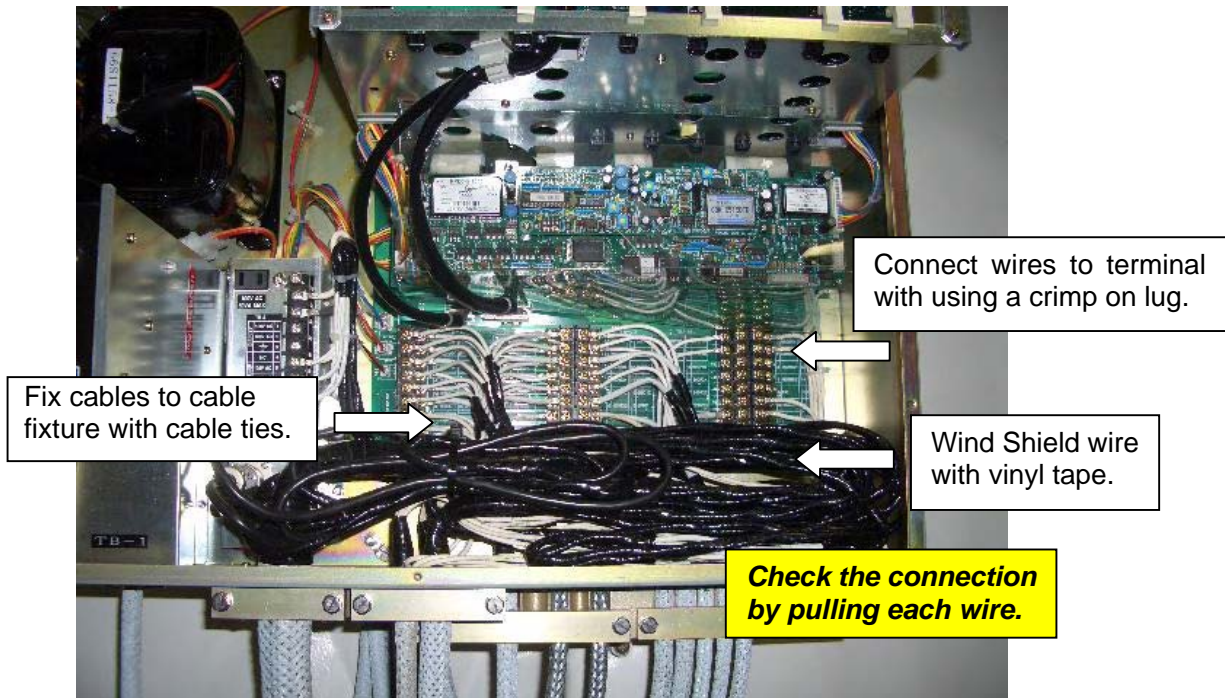
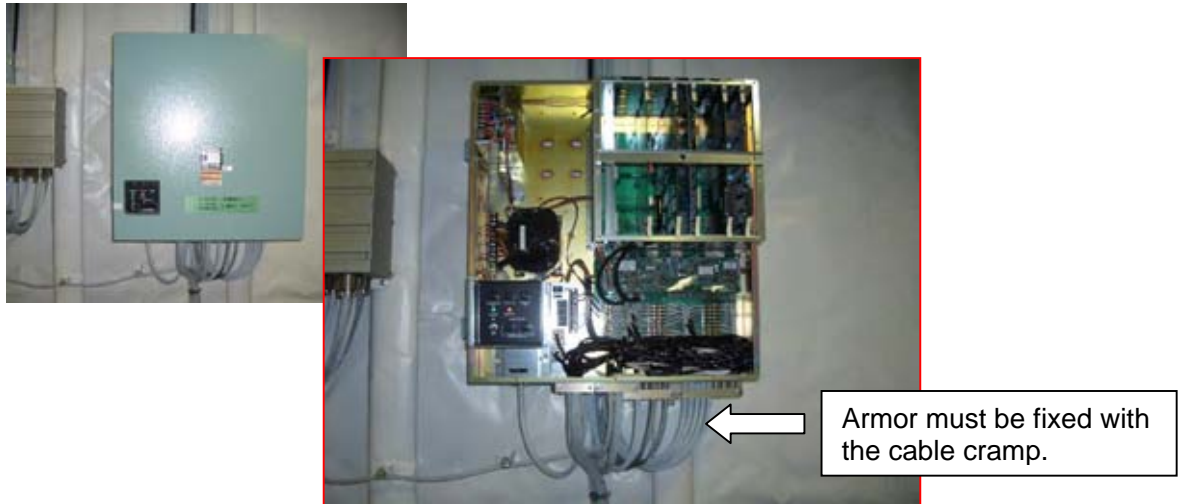
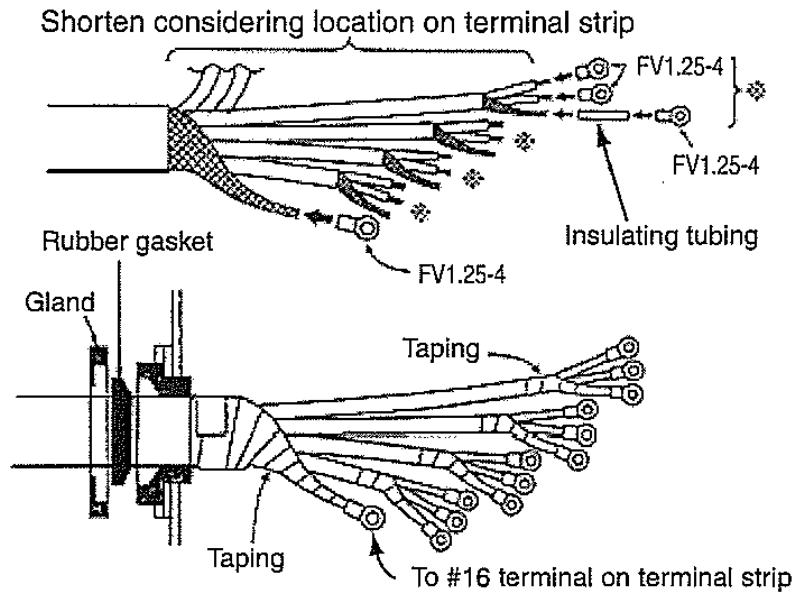

Fig. 12.5.3 DS-50 Processor unit (DS-511)

Cable Fabrication of DS-50

1. Transducer cable



2. Cable between transceiver unit, junction box and processor unit (TTYCY-19S)

a. Transceiver unit/ junction box

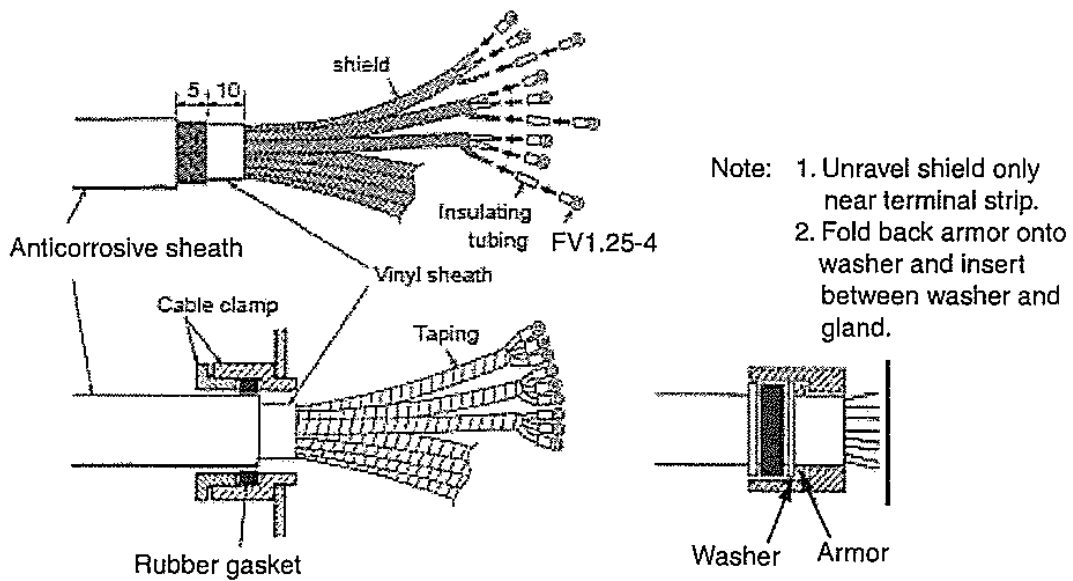

b. Processor unit

Cores and shields are fabricated the same as on transceiver unit/junction box side. To ground the cable, remove paint from the armor and set the armor in the cable clamp.

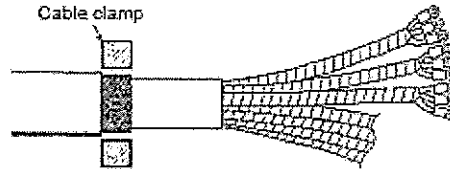

3. CIF/NMEA Data Signal Cable (CO-SPEVV-SB-C 0.2X5P)

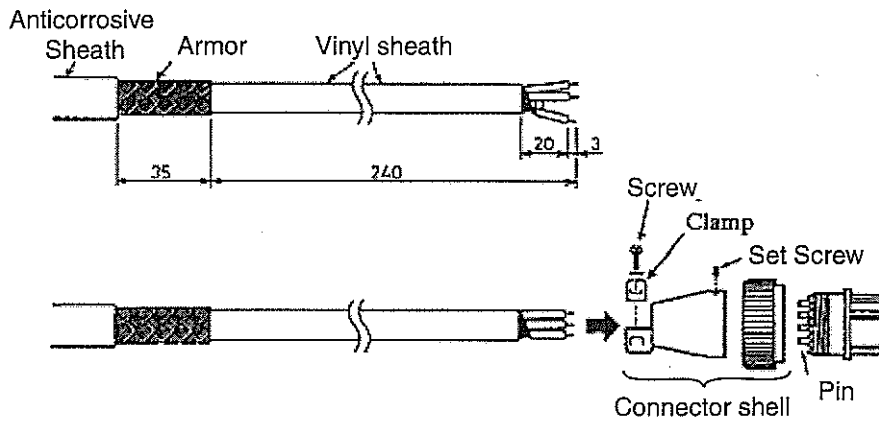

4. Other Cables

All other cables are terminated at a terminal strip.

- <Cable passed through cable clamp>
Locate the armor in the cable clamp.

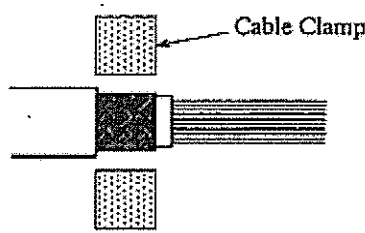

- <Cable passed through cable gland>

Solder a vinyl wire w/crimp-on lug to the armor and fasten it to the earth terminal.

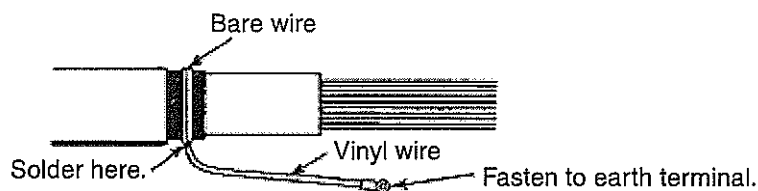

Processing the shield

<Individual shields>

Undo individual shields only near the terminal strip to which its wire is connected.
Tape shields for insulation.

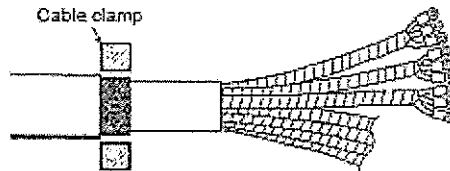

<Common shield>

Undo individual shields only near the terminal strip to which its wire is connected.
Tape shields for insulation.

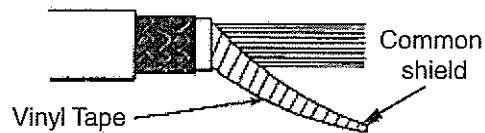

12.5.2 Example of DS-30 installation

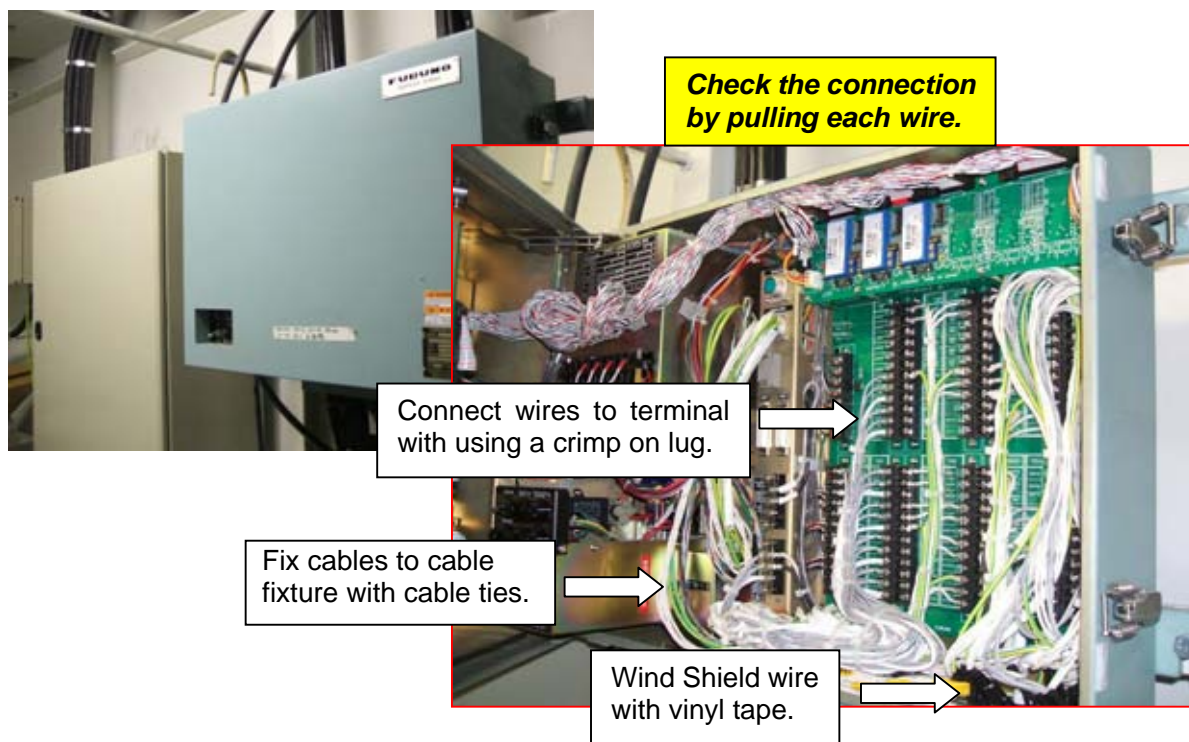

Fig. 12.5.4 DS-30 Processor unit (DS-310)

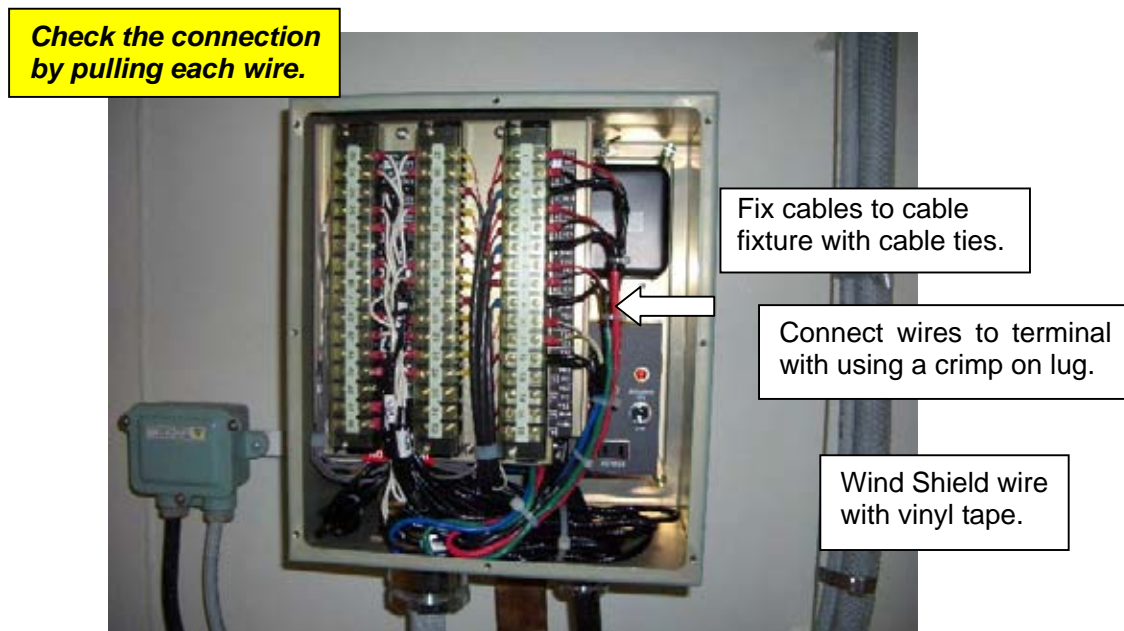
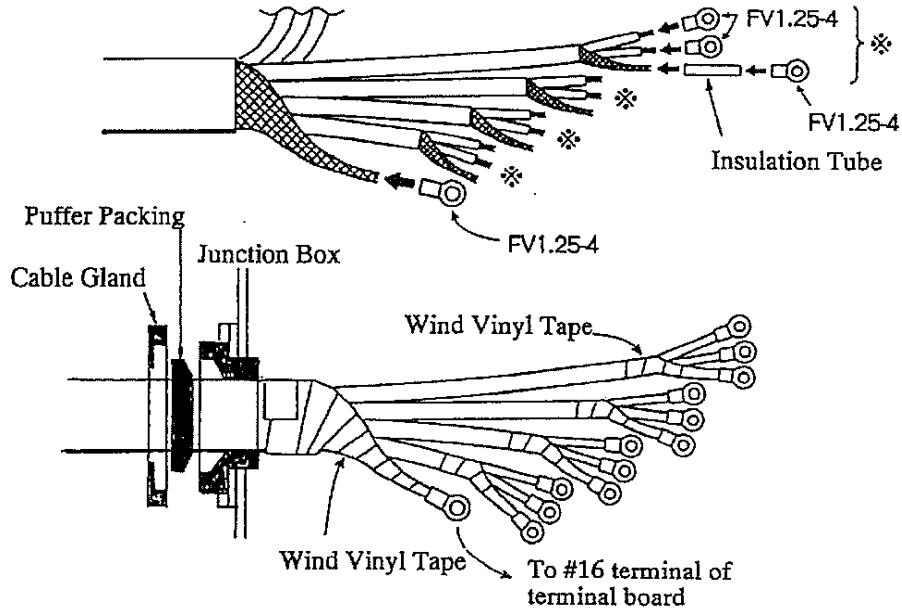

Fig. 12.5.5 DS-30 Junction unit (DS-360)

Cable Fabrication of DS-30

1. Transducer cable



2. Cable between transceiver unit, junction box and processor unit (TTYCY-16S)

1) Transceiver unit, Junction box side

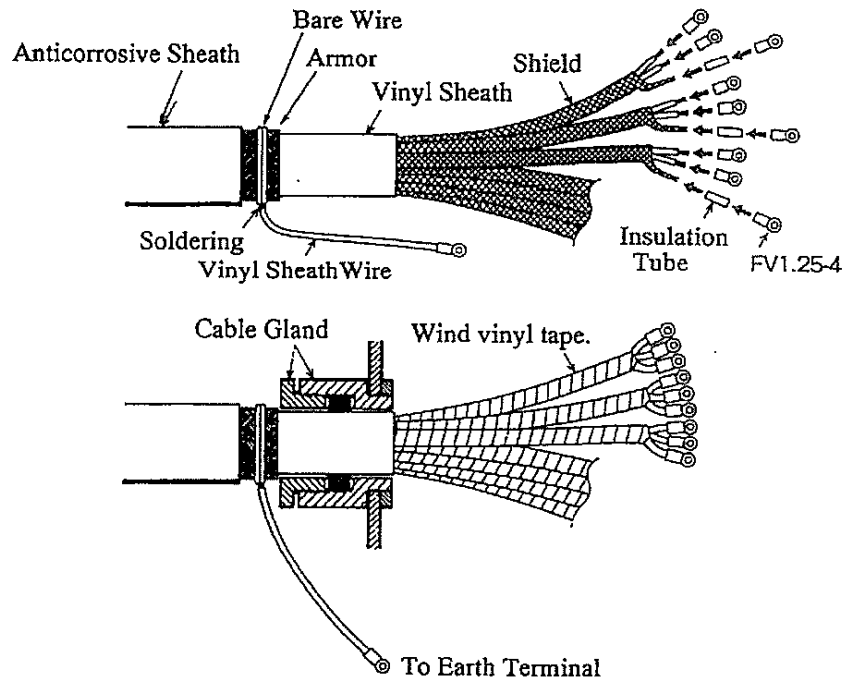

Note: Do not undo the shield at the entrance into the unit. Noise induction through unshielded wires cause equipment malfunction.

2) Processor unit side

Fabricated the wires and shield in the same way as the transceiver unit/junction box side. For the cable armor, remove paint and ground it through the cable clamp.

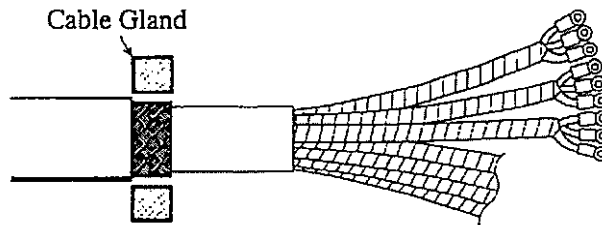

3. Cable between Processor unit/Main display unit/sub display unit (CO-SPEVV-SB-C 0.2x10P)

Connect the 20p connector as follows.

1) Cable Fabrication

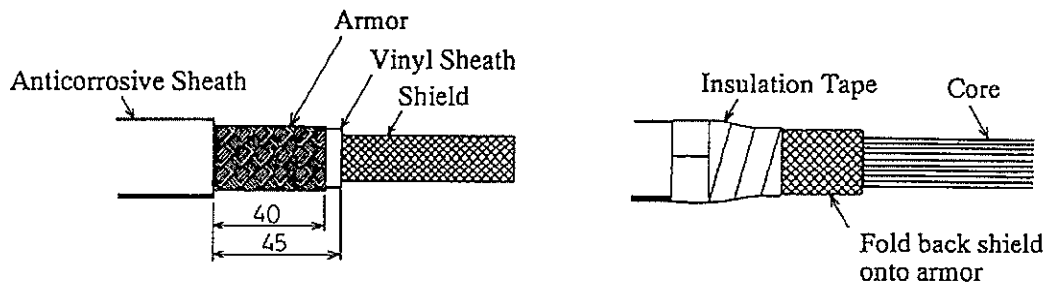

2) Crimping Tool and Crimping method

A special crimping tool is necessary for connection of wires to the contact pins of 38P connector 00-8016-038-000-751. Also a pin extractor should be used to push out the contact pin from the connector body. The following describes how to crimp and extract the contact.

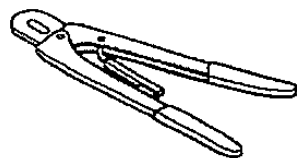

Crimping Tool
06-1001-016

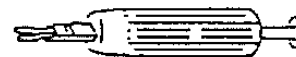

Pin Extractor
06-1877-04

3) Wire Crimping procedure

1. Strip the vinyl sheath of the wire to expose the core by 3 mm to 4 mm.
2. Hold the crimping tool horizontally and insert the contact pin with its slit faced downward into the crimp hole on the crimping tool.
3. Insert the wire onto the contact pin and squeeze the handle until the ratchet releases. Note that the wire should be inserted deep enough until its end comes in contact with the stopper plate of the crimping tool. After crimping, pull the wire to make sure that it is securely fixed.

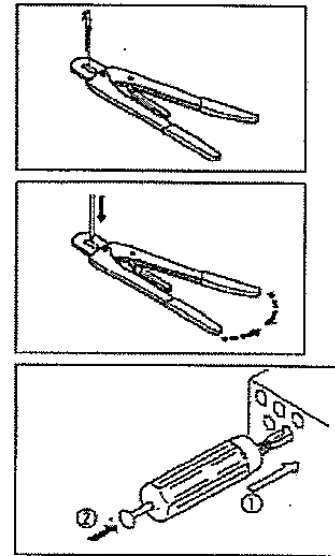

4) Inserting contact pin into connector housing

The contact pins fitted to wires should be inserted into the connector housing referring to the interconnection diagram.

5) Procedure to extract contact pin

When a contact pin is inserted into an incorrect hold on the connector body, take it out by using the pin extractor.

1. Push the pin extractor into the pin hole from the side opposite to the pin inserting side.
2. Push in the head of the pin extractor, and the contact pin is unlocked and pushed out.

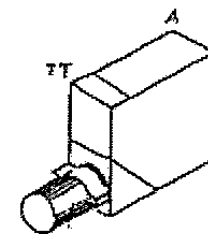

Cable out going direction

6) Assembling connector housing

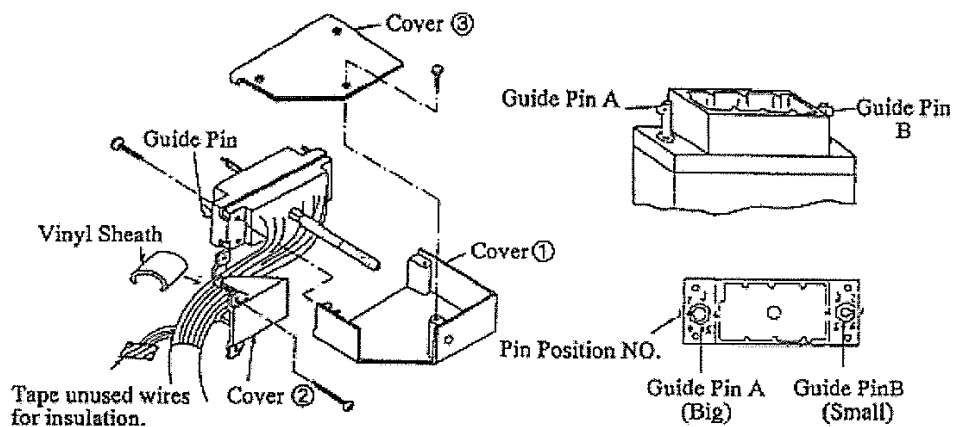

1. Fix the cover "1", paying attention to the cable outgoing direction.
2. Dress the wires and put covers "2" and "3" on.
3. Use a fragment of cable sheath to fix the wires with the connector clamp.
4. Cut the unused wires to proper length and wrap their ends with vinyl tape.

Note: Cover "1", "2" and "3" are not fitted on the connectors contacted to the main and sub display units.

7) Clamping cable

Clamp the shield and armor of the cable with cable clamp.

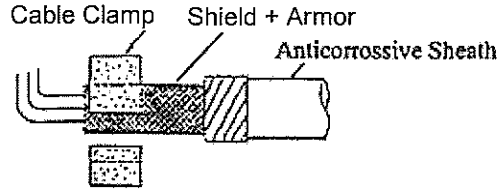

4. CIF/NMEA Data Signal Cable (CO-SPEVV-SB-C 0.2X5P)

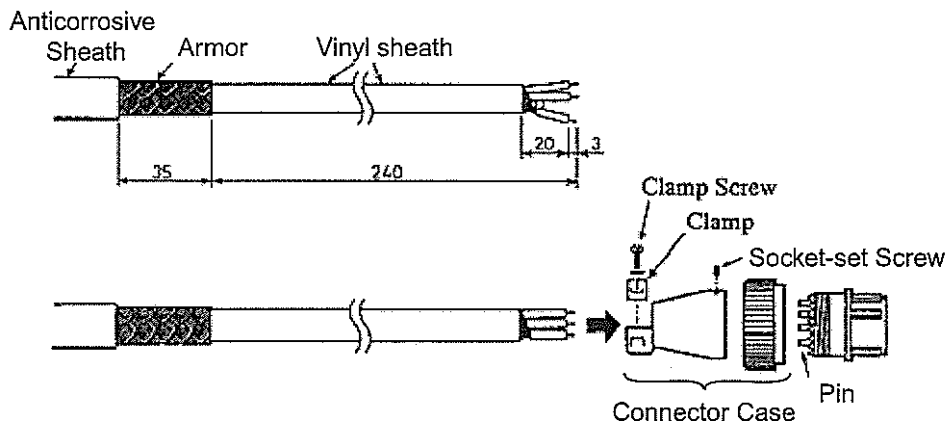

5. Other Cables

All other cables are connected to terminal boards. Fabricate their ends as follows.

1) Cable Armor

<for cables led in though cable clamp>

Expose the armor and clamp it with the cable clamp.

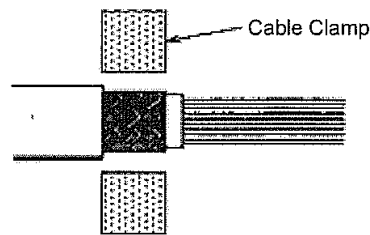

<For cables led in though cable gland>

Solder a vinyl sheath wire to the armor and connect it to the grounding terminal.

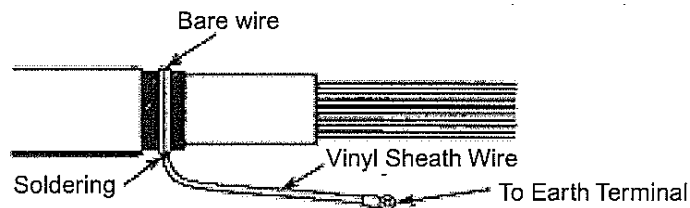

2) Cable shield

<For individual shield>

Undo individual shields only near at the terminal boards to which the wires are connected. Further, tape shields for insulation.

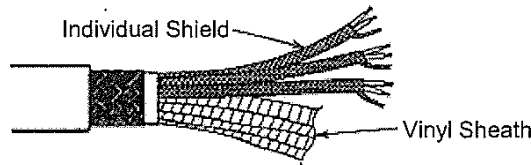

<For common shield.

Undo common shield at entrance of the unit and tape it for insulation.

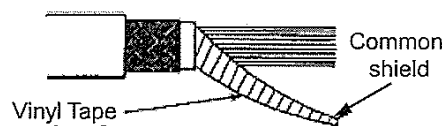

6. Insulation of cables for transducer

Insulation check

1. Remove all cores and shields of the transducer from the terminal board. All wires of the transducer are open.
2. Set the multimeter to the maximum resistance range and measure the resistance between each transducer line (TD1, TD2, TD3) and individual or common.

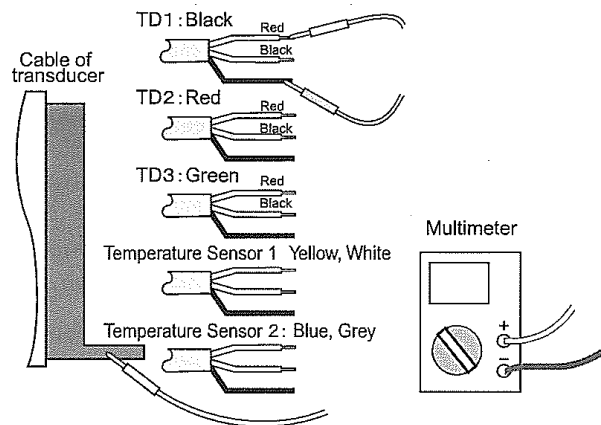

Measurement places		Insulation resistance value
- polarity lead	- polarity lead	
Red wire of black sheath	Shield in black sheath	Digital multimeter: More than 10 M-ohm, Analog multimeter: Needle dose not swing.
Red wire of black sheath	Common shield	
Red wire of red sheath	Shield in red sheath	
Red wire of red sheath	Common shield	
Red wire of green sheath	Shield in green sheath	
Red wire of green sheath	Common shield	

Note: If rating is not met a location, suspect faulty insulation. Replace a new one.

Appendix 1. Acoustic Equipment

AP1.1 Transducer Position (DS-30/50/80, FE-700)

AP1.1.1 Best location

Select following locations for the transducer of acoustic equipment, such as a Doppler sonar and Echo sounder.

1. Location where is lightly affected by bubbles.
2. Location where is lightly affected by propeller and side thruster noises.

The most important thing is to avoid bubbles.

Flow of air bubbles created at ship's bow varies from hull to hull and according to ship's speed. Typically, bubbles flow along the hull as shown in Fig. AP1.1.1.

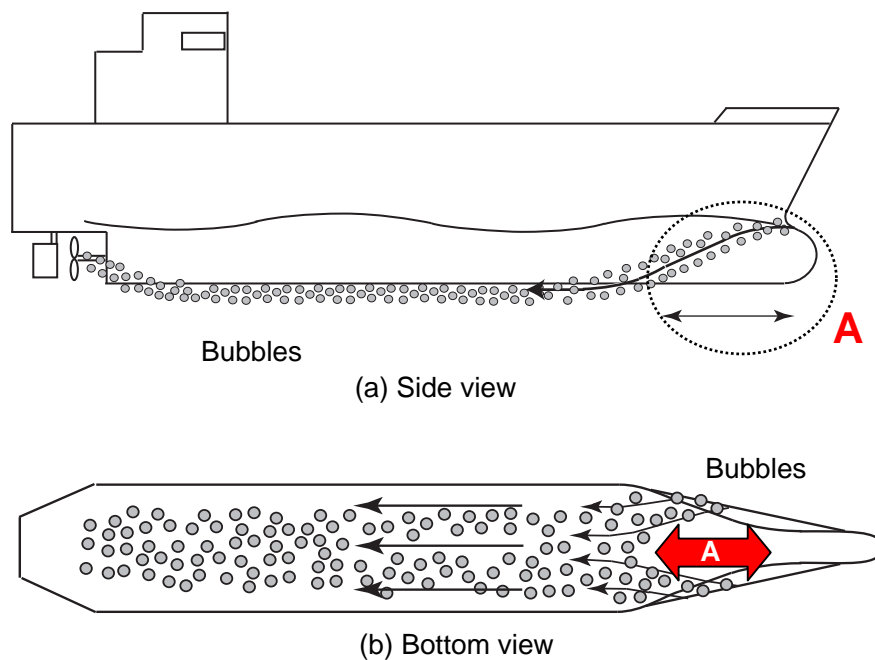

Fig. AP1.1.1 Flow of bubbles

- The best location for the transducer shows arrow (a) in Fig. AP1.1.1.
- The example of an installation is Fig. AP1.1.2.

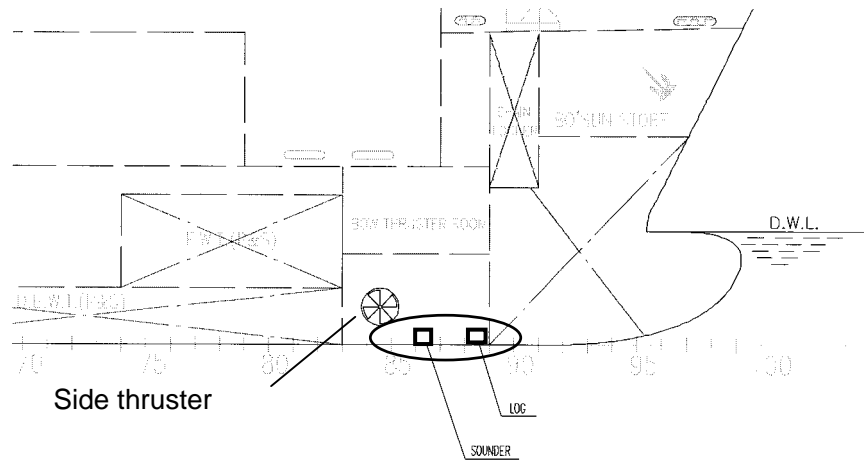

Fig. AP1.1.2 Location of transducer

The performance of the Doppler sonar is easily degraded by bubbles, so the transducer must be placed at the location "A" as shown in Fig. AP1.1.1.

Transversely, the transducer is mounted on the keel or as near to the keel as possible.

When side thruster is installed;

The transducer is mounted in front of the side thruster about 1 m.

Installation at bow bulb

If the bottom is not flat, the transducer tank must be welded as shown in Fig. AP1.1.3 to make the transducer surface flat. The installation at an angle will cause a false reading of depth.

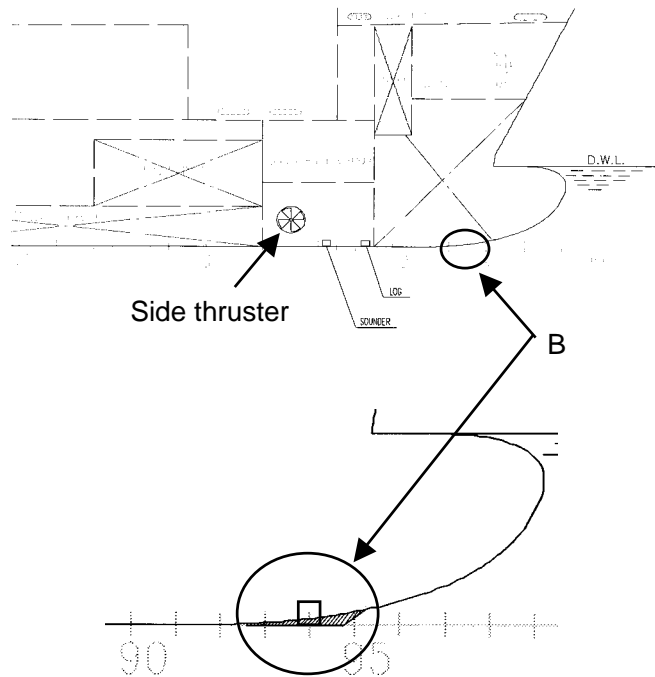

Fig. AP1.1.3 Installation at bow bulb

Location for transducer of Echo sounder

The best position is the above-mentioned B. Installation at other areas may be affected by air bubbles and cause unstable depth indications. The lower frequency, the more the air bubble interference. Use 200 kHz transducer which there is the possibility of air bubble interference.

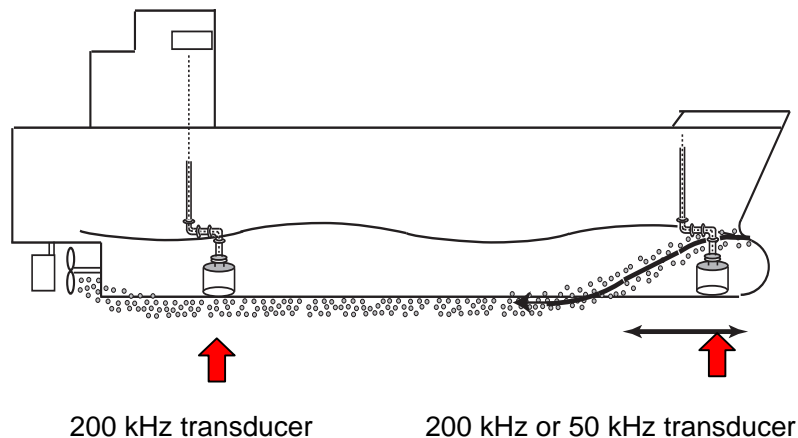

Fig. AP1.1.4 Location of Echo sounder transducer

AP1.1.2 Installation of Echo sounder and Doppler sonar transducers

Decide location of Doppler sonar transducer first.

When installing Doppler sonar and Echo sounder transducers, decide the location for the Doppler sonar transducer first. The Echo sounder transducer is placed behind the Doppler sonar transducer about 2 m or more.

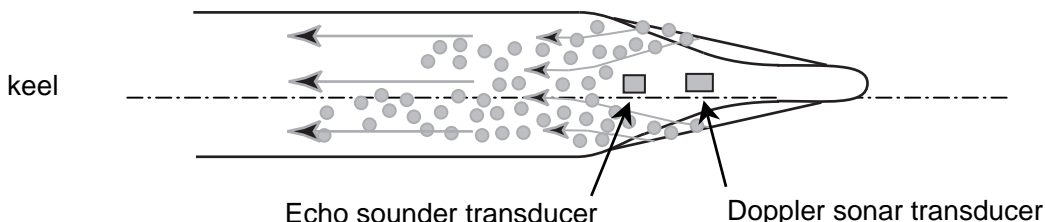

Fig. AP1.1.5 Echo sounder and Doppler sonar transducers

The recommended area for Echo sounder transducer to be mounted shows Fig. AP1.1.6.

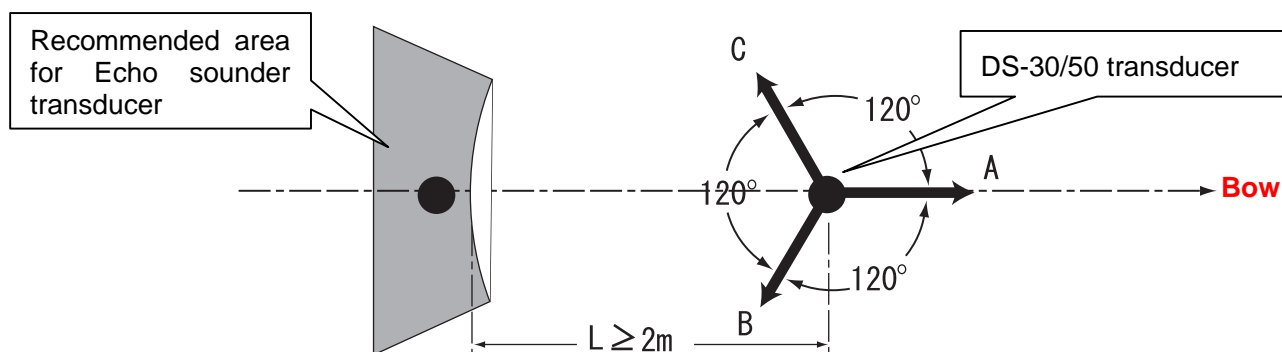

Fig. AP1.1.6 DS-30/50 and FE-700 transducers

Doppler sonar transmits three beams in directions A, B and C. Never place the Echo sounder transducer in the directions A, B and C.

DS-80 and FE-700

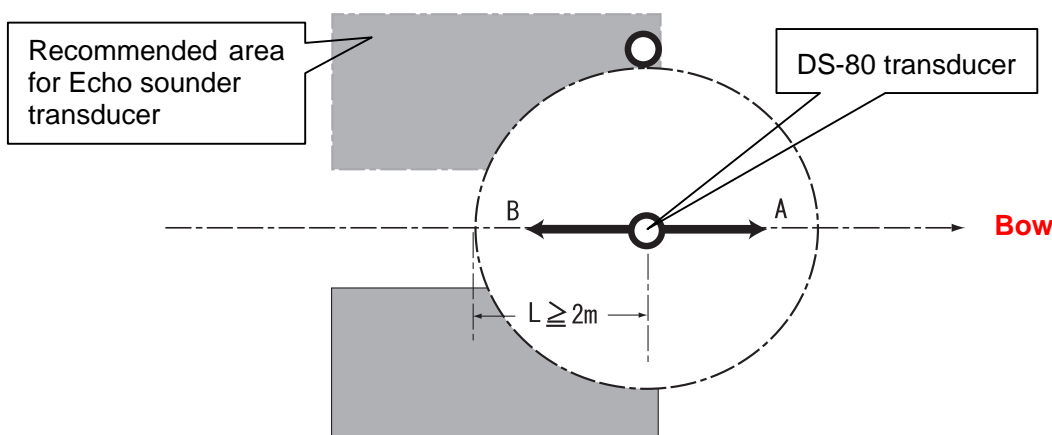

Fig. AP1.1.7 DS-80 and FE-700 transducers

AP1.2 Piping Transducer cable

Pipe the cable from the transducer flange to the transducer or matching box.

Note: The transducer cable of Doppler sonar must be piped.

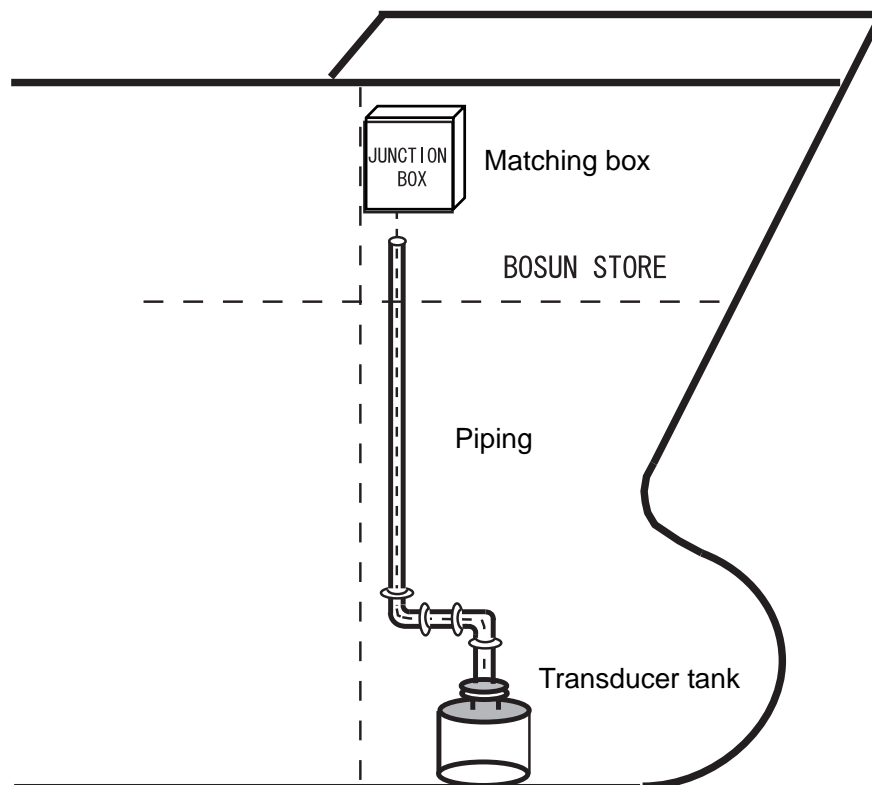

Fig. AP1.2.1 Piping transducer cable

AP1.3 Installation on ship with protruded keel

When the transducer is mounted in the keel, take followings into account to prevent the adverse affect from bubbles.

1. "In keel" installation

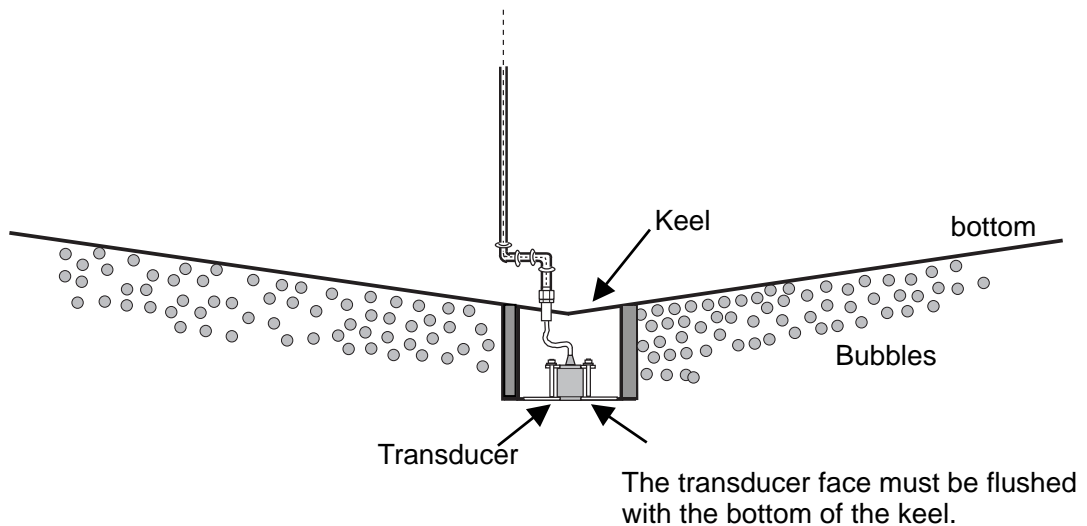

Fig. AP1.3.1 "In keel" Installation

2. "Beside keel" installation (Using tank)

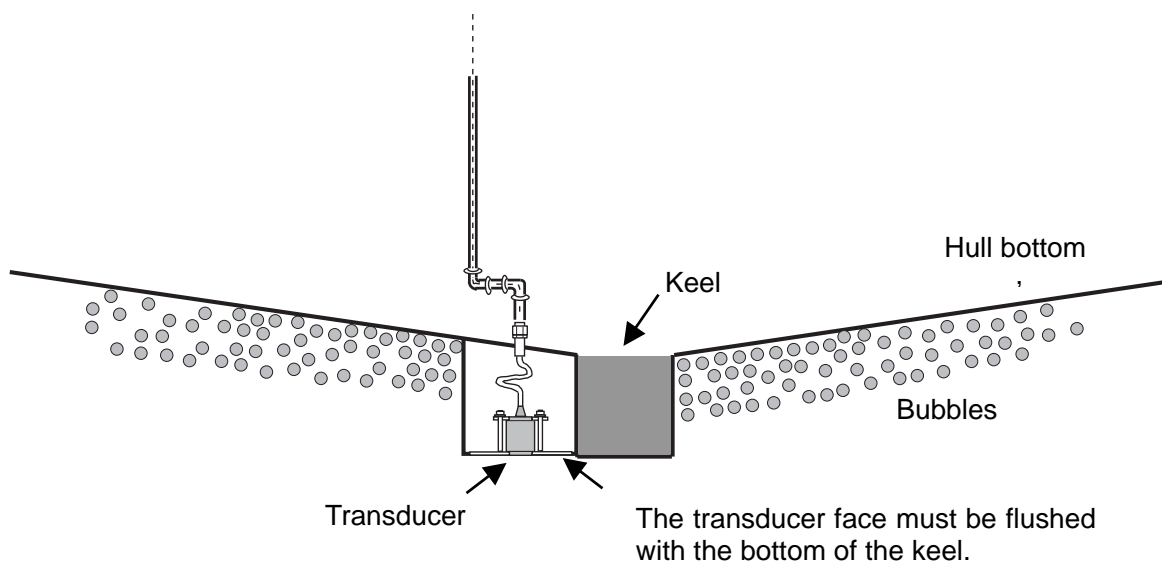

Fig. AP1.3.2 "Beside keel" installation

3. "Parallel to keel" installation (Using tank)

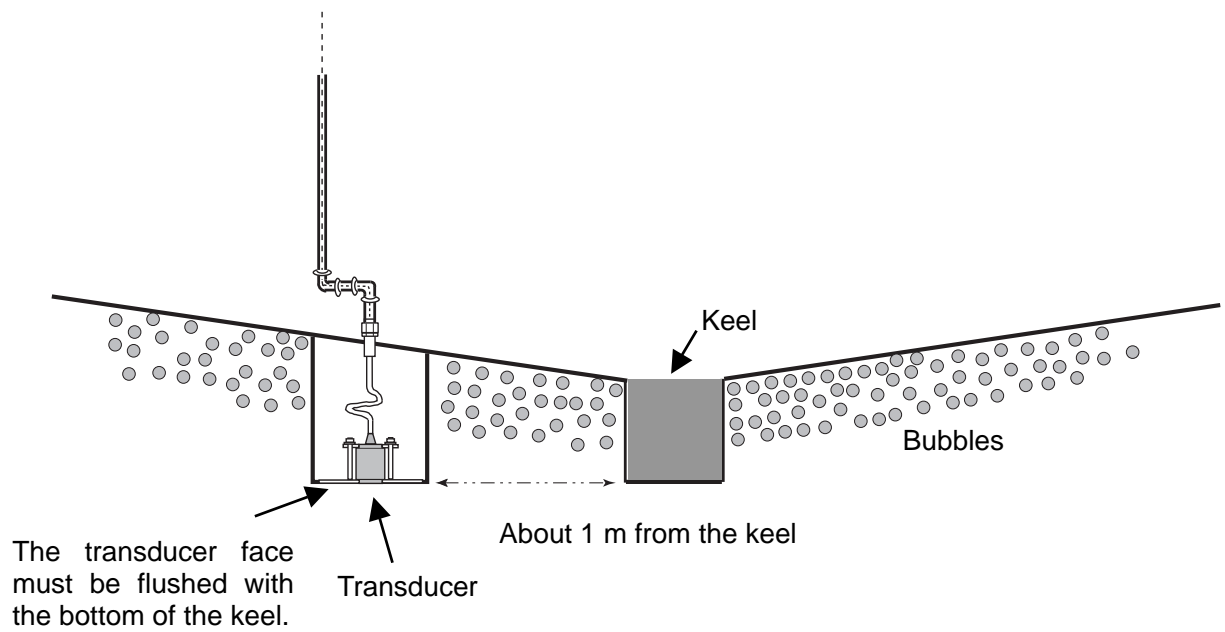

Fig. AP1.3.3 "Parallel to keel" installation

Appendix 2. Antenna Installation

AP2.1 Safety measures

AP2.1.1 MF/HF antenna

For the transmission antenna installation of MF/HF radio equipment, safety measures for high-voltage electricity should be considered.

Where high-voltage electricity runs; e.g. feeder, secure the height 2.5 meters or more from the deck where crews walk. However, as far as the portion lower than 2.5 meters has a construction which does not easily come in touch with a human body, or as far as it is located at the place which the human body does not readily come in touch with, this shall not apply.

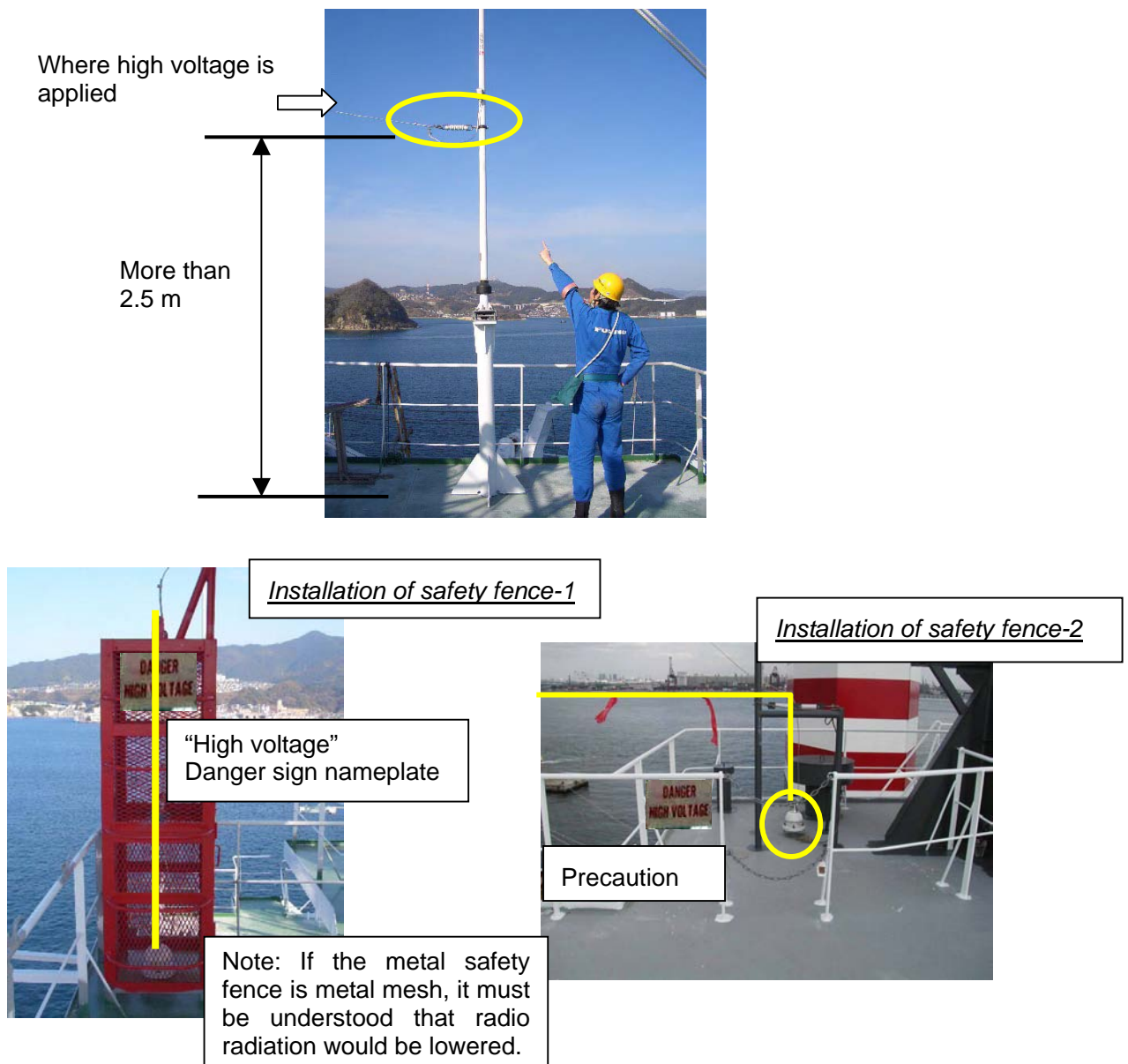

Fig. AP 2.1.1 Example of safety measures for transmission antenna

AP2.1.2 Caution label

Radio waves can be harmful to the human body. Since safe distances differ by country and ship construction there is no uniform formula for calculating safe distance. However, general guidelines are below.

Personnel should not approach an area in which the radiation level is higher than 10 W/m², e.x., within 4 m from the radome surface.

For example, apply Caution Label

1. A prominent place under the antenna mast (to the dome, one sheet is affixed but people may come close to the dome to read the characters written and does not work as the prevention of disability. Understand the purpose and choose appropriate place.)
2. A prominent place at the approaching place to compass deck that is rigged with the radome.

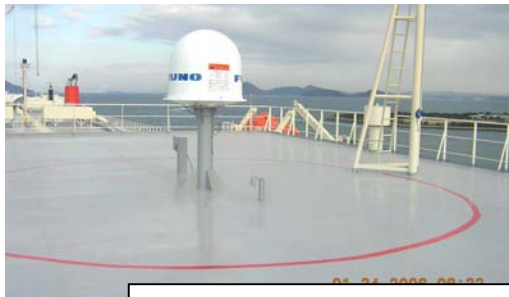

For example, it is one method to paint a danger zone.

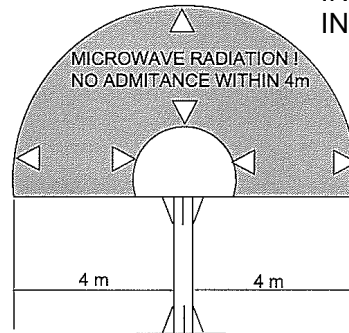

INMARSAT B: 6 m
INMARSAT F: 4 m



Affix a caution label for radio waves of high radiation level.

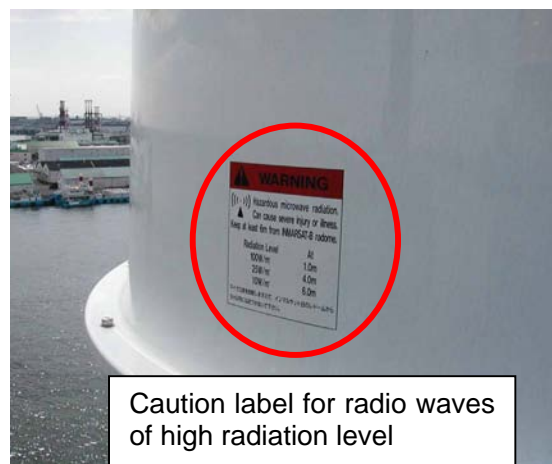

Caution label for radio waves of high radiation level

Fig. AP2.1.2 Examples of safety indications by INMARSAT radiation levels

AP2.2 Antenna arrangement

In order to satisfactory communication, the distance between necessary antennas should be ensured, and interference between antennas should be reduced. However, in case the antenna is mounted to a compass deck or radar mast with a limited space, there are cases in which the antenna is unable to be mounted as per the guidelines stipulated herein or it is difficult to mounted the antenna, but consider the mounting in conformity to the purport of this document as much as possible. The basic concept of antenna mounting includes:

1. Each antenna should be rigged out of beams of radar or INMARSAT.
2. Rig with receiving antennas kept more than 1 m away.
3. Rig with VHF transmission antennas including AIS kept away as much as possible. If possible, keep them more than 10 m away.
4. Separate between MF/HF transmission antennas and receiving antennas as much as possible.
5. Rig the antenna of INMARSAT C to the top of the radar mast free of obstacles. In addition, grasp the shadow sector of INMARSAT B, F and explain users.

Rigging example of INMARSAT F radar mast

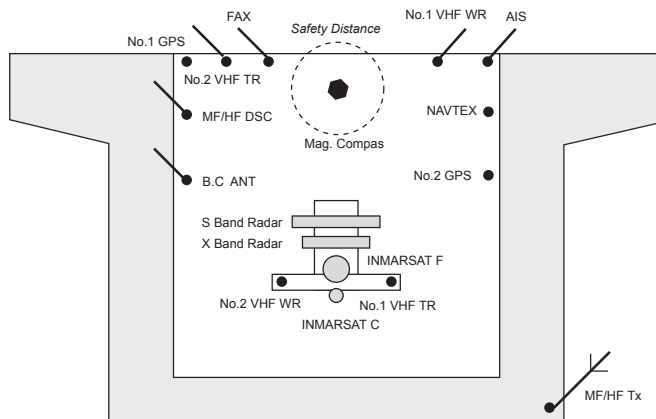

Mount antennas outside the compass safety distance which magnetic compass requires.

Example of rigging two INMARSAT C

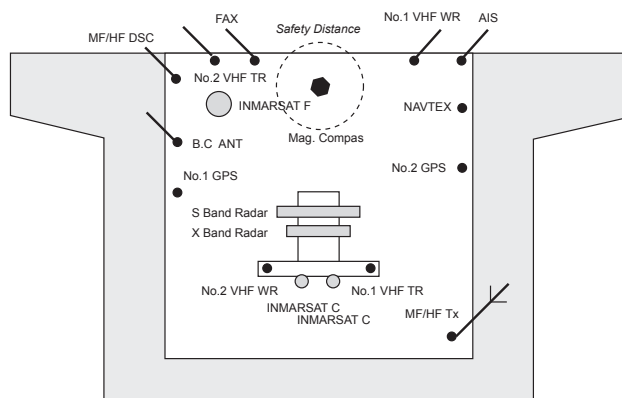

Mount antennas outside the compass safety distance which magnetic compass requires.

AP2.2.1 INMARSAT antenna

INMARSAT C antenna

Mount the omnidirectional antenna unit high atop a mast clear of stays and the turning diameter of a radar antenna. The ideal mounting location would be where no obstacle appears in the fore and aft directions down to -5° and down to -15° in the port and starboard directions. This concept is shown in the figure below. Shadow sector of the antenna mast, whip antenna, etc. should be within 2 degrees at one meter from the antenna unit.

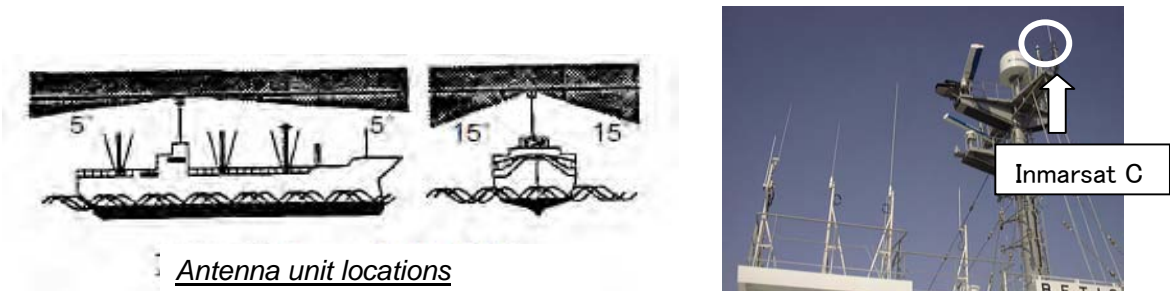

Fig. AP 2.2.1 Antenna arrangement of INMARSAT C

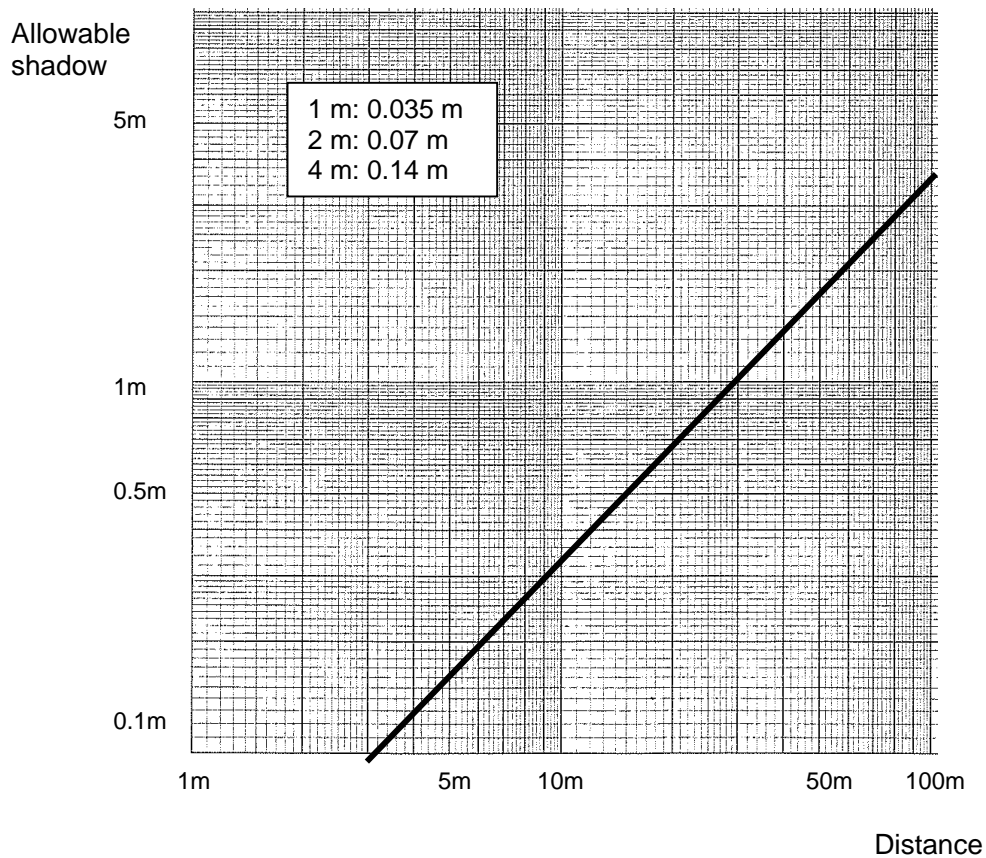
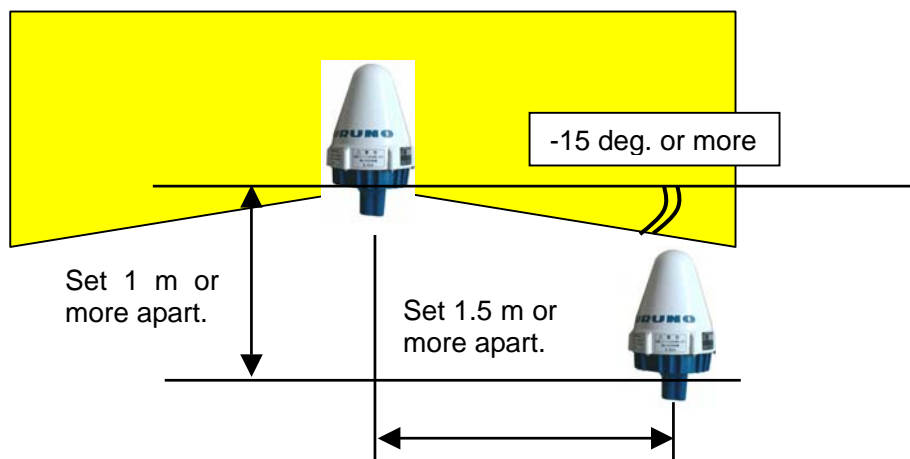

Fig. AP2.2.2 Size of allowable shadow sector of INMARSAT C

1. Rigging of two INMARSAT C antennas

The arrangement should be carried out as below. Adjust heights between two antennas so that any of the antennas does not enter the following range. Keep at least 1.5 m distance between two antennas in order to avoid interference between antennas. Provide 1 m or more level difference between two antennas.



2. Relation between INMARSAT C and INMARSAT B, F

Provide more than 3.5 m distance between INMARSAT B, F and INMARSAT C antennas. If beams of INMARSAT B, F are directed to the antenna of INMARSAT C, INMARSAT C can not synchronize to the receiving signal.

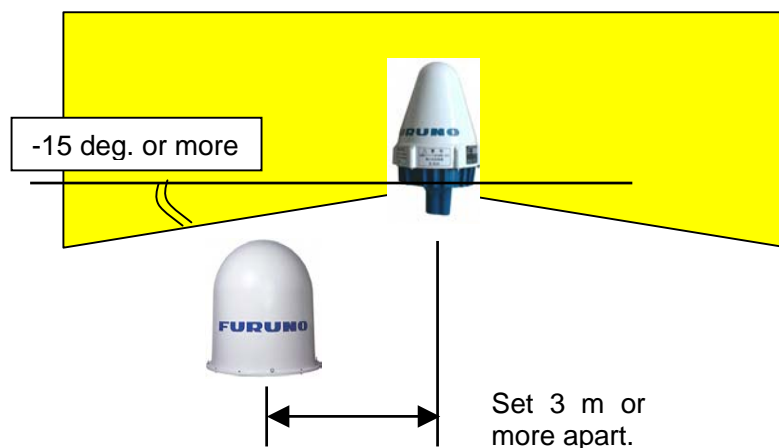

3. Rigging of INMARSAT B, F antennas

Antenna blocking should be considered. Mount INMARSAT B, F at locations free of any obstacles (radar mast, etc.) that exceed 6° within 10 m from INMARSAT B, F antennas.

The size of an obstacle of 6° at 10 m distance is about 1 meter.

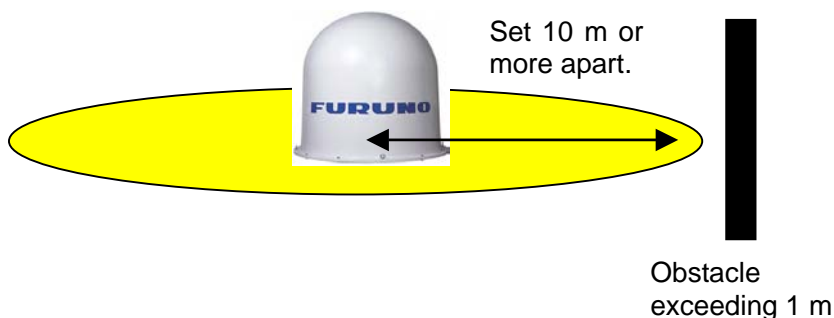

4. Relation between INMARSAT B, F and GPS antenna

Keep them 5 m or more away from each other. If GPS antenna is rigged at locations within 5 m from INMARSAT B, F antennas, rig it deviated more than 2 m from INMARSAT beams.

Directing INMARSAT B, F beams to the GPS antenna lowers the GPS reception level.

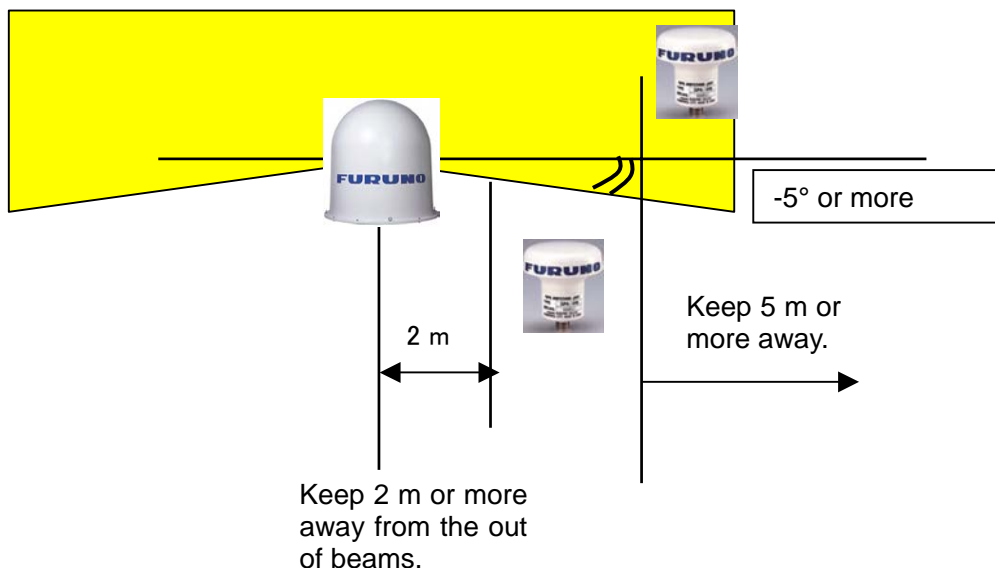

5. Relation between INMARSAT C and GPS antenna

Keep them at least 3 m away from each other. If GPS antenna is rigged at locations within 3 m from INMARSAT C antenna, rig it deviated more than 1 m from INMARSAT beams.

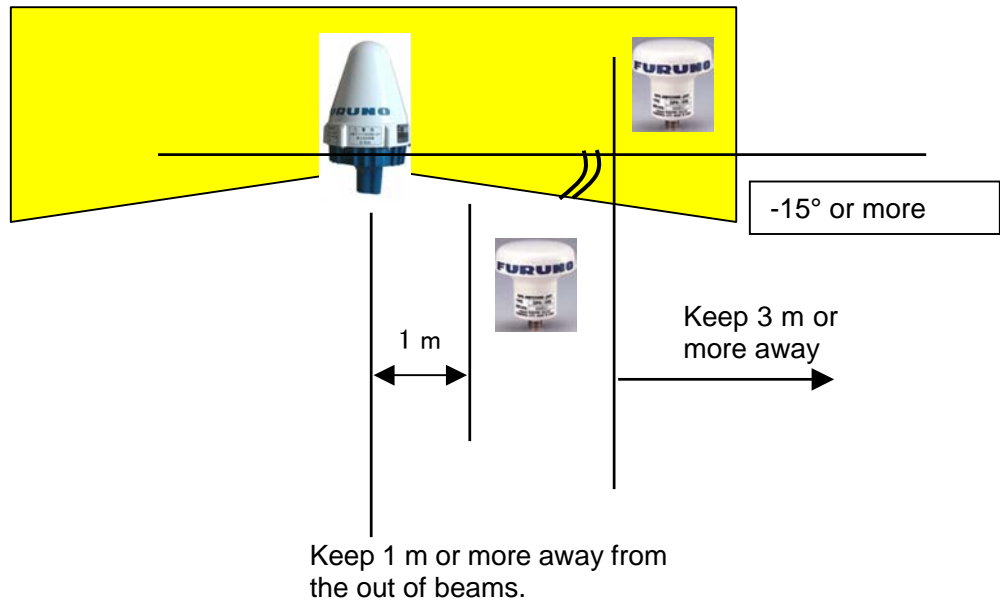

6. Relation between INMARSAT B, F, C, GPS and S band radars

Deflect from radar beams and avoid rigging in an area within 5 m from radar antenna.

Mount INMARSAT C to the location above the shaded areas of the figure below so that antennas are not subject to S-Band radar interference.

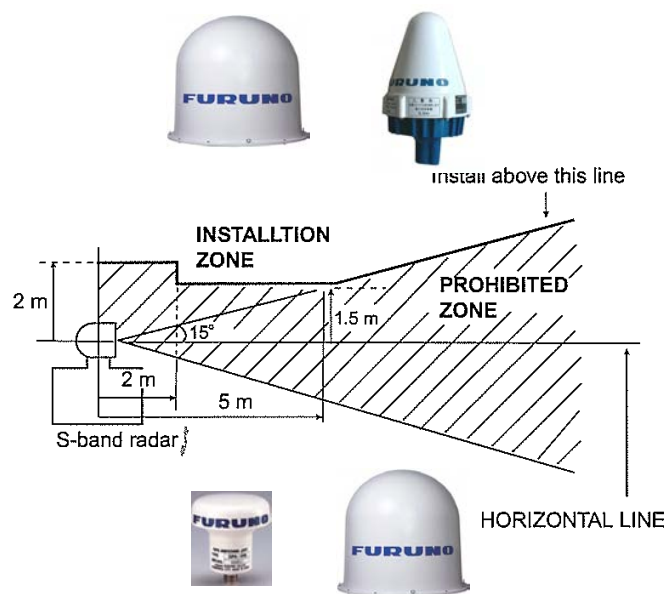

7. Relation between INMARSAT B, F, C, GPS and X band radars

Avoid rigging in an area within 5 m from radar antenna.

If it is unavoidable to rig antennas in an area within 5 m from radar antenna, adjust height between antennas so that antennas are not subject to radar beams in the range within $\pm 15^\circ$.

If locations are kept 5 meters or more apart from radar antenna, adjust the height between antennas so that antennas are not subject to radar beams in the range within $\pm 10^\circ$.

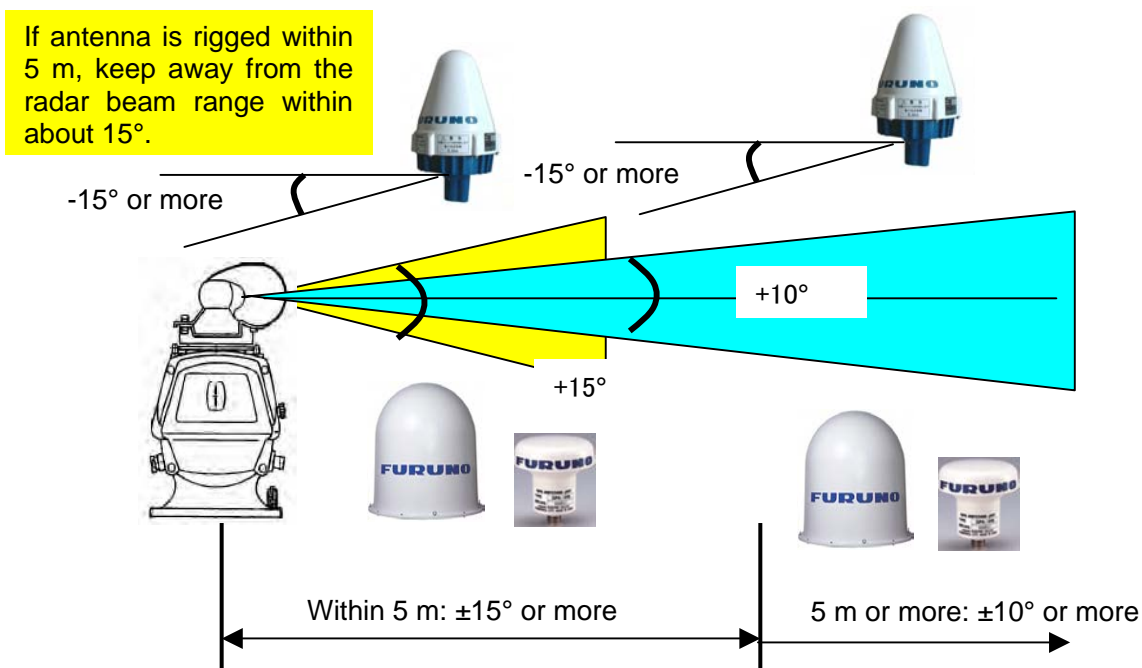

AP2.2.2 VHF (AIS) antenna, MF/HF antenna

1. Relation between VHF antenna, MF/HF antenna and INMARSAT B, F, C

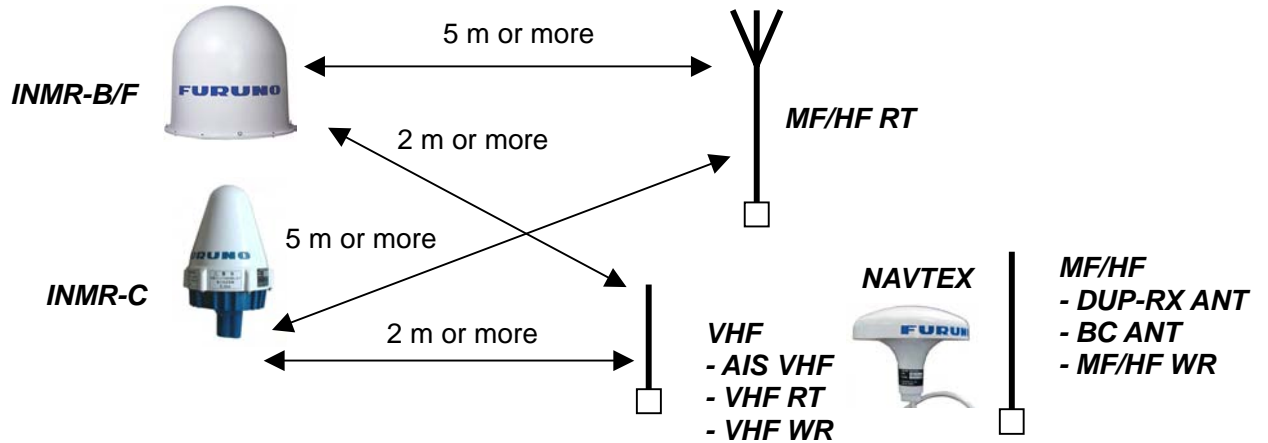

2. Relation between VHF antenna and MF/HF antenna

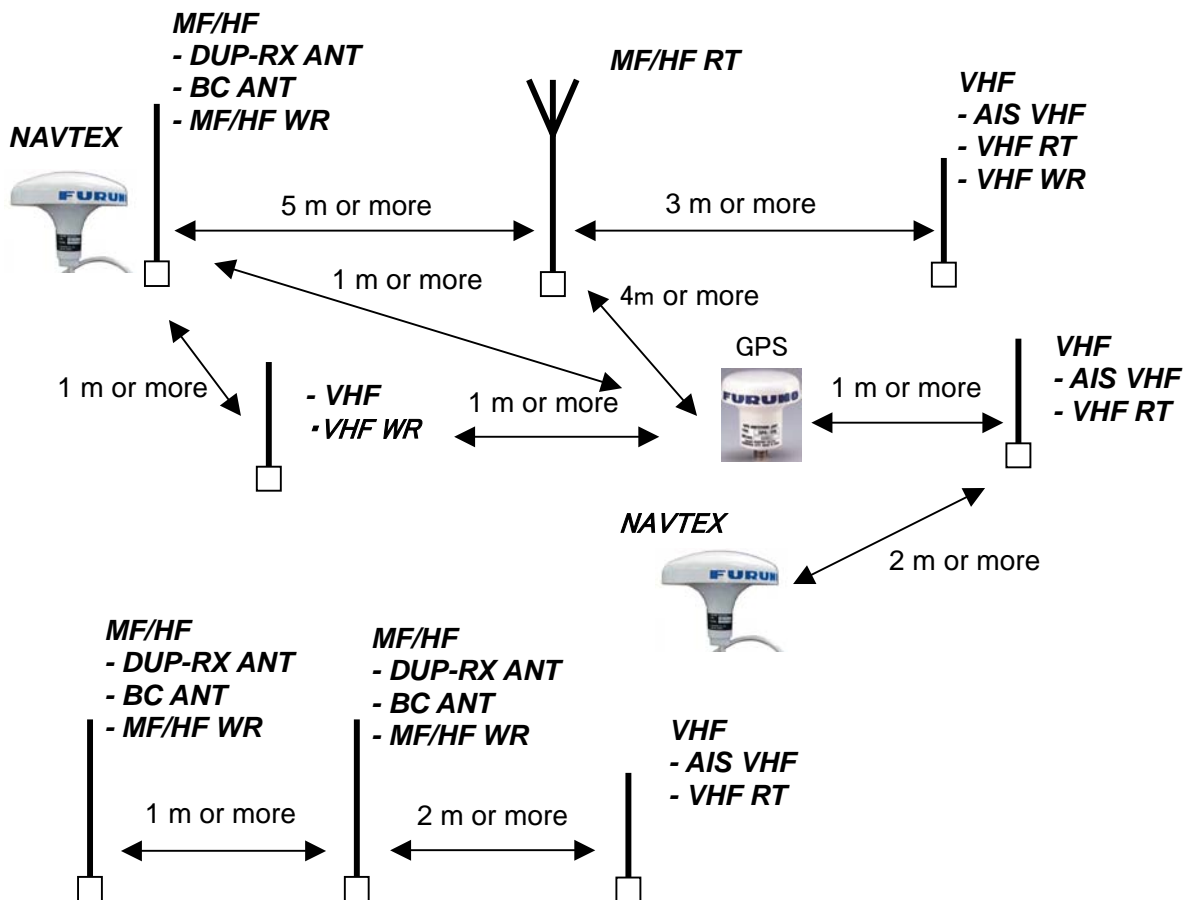

3. Relation between VHF antenna and VHF antenna

Note that channels which cannot avoid interference occur even if antennas between VHF telephones are kept away 5 m to 10 m.

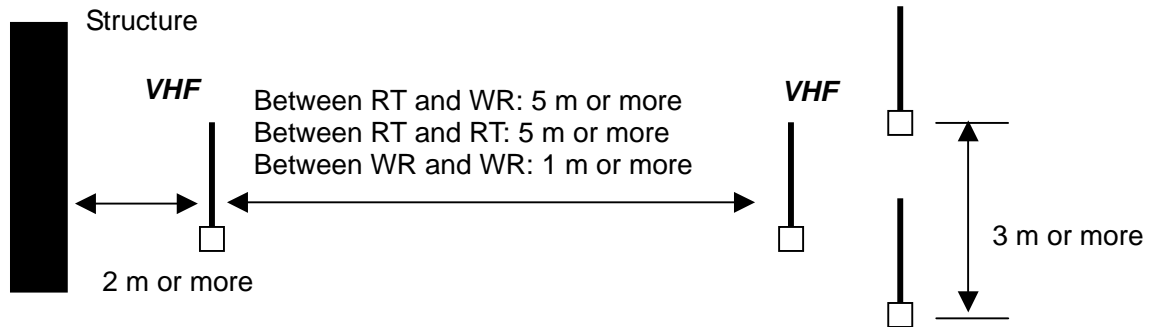

4. Relation between VHF antenna and AIS antenna

When VHF radiotelephone interferes with AIS, the AIS target is lost. The target-lost conditions differ according to ship speeds and navigation status. For example, with FA-150, in the case of a target with ship speed lower than 14 knots, it becomes a “Lost target” when no signal is received from the target for 50 seconds.

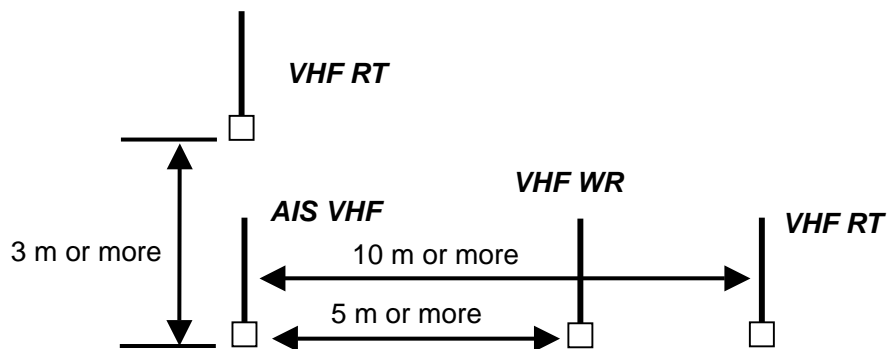

5. Relation between VHF antenna, MF/HF antenna and radar antenna

In case the distance between VHF antenna, MF/HF antenna and S, X band radar antennas is within 5 m, install VHF antenna, MF/HF antenna without radar beam zoon.

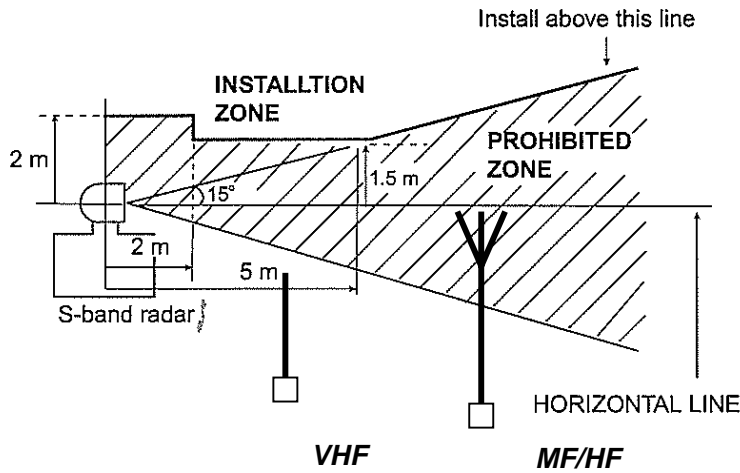

6. Points to be remembered in mounting MF/HF antenna

It is recommended that a feeder angle is 45 degrees or more in order to improve radio radiations.

In addition, when the antenna feeder line is connected to the antenna terminal of the antenna coupler, it is required to prevent slacking at antenna connections or feeder breakage due to feeder swinging.

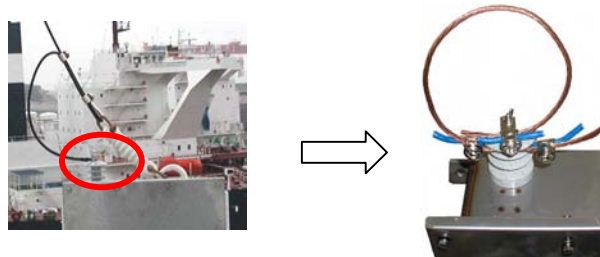

In case of duplex operation, it should be considered for prevention of interfering from transmitting signal to receiving signal. Keep the receiving antenna away from the transmission antenna as much as possible. (For example, mount receiving antennas to the fore mast.)

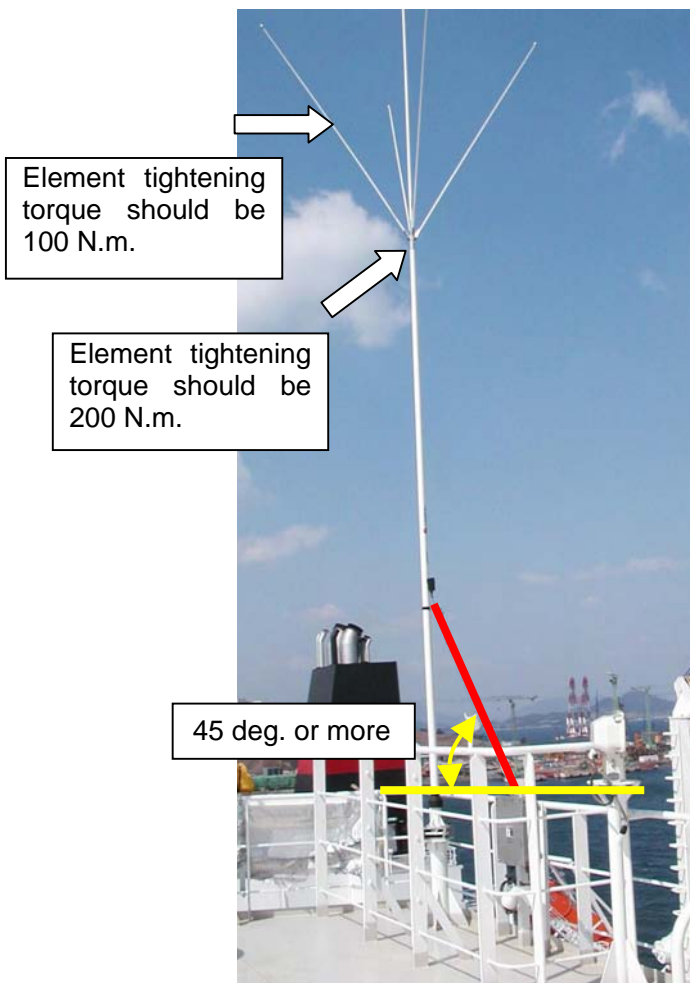

Grounding of antenna coupler

Use 50-mm or wider copper plates to establish ground.

If the copper strap is more than 1 meter, use a 100 mm wide copper strap.

Reference:

Oscillation range of AT-101DS antenna;

Keep more than 5 m away in order to avoid contact of AT-101DS antenna with radar mast and other structures.

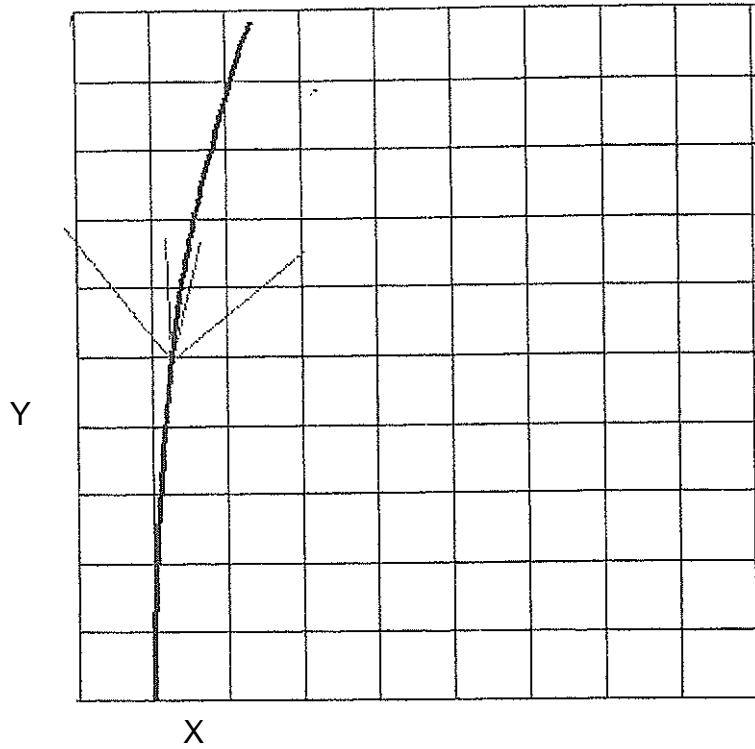

Wind velocity: 20.0 m/s
 $X = 1.47$ m

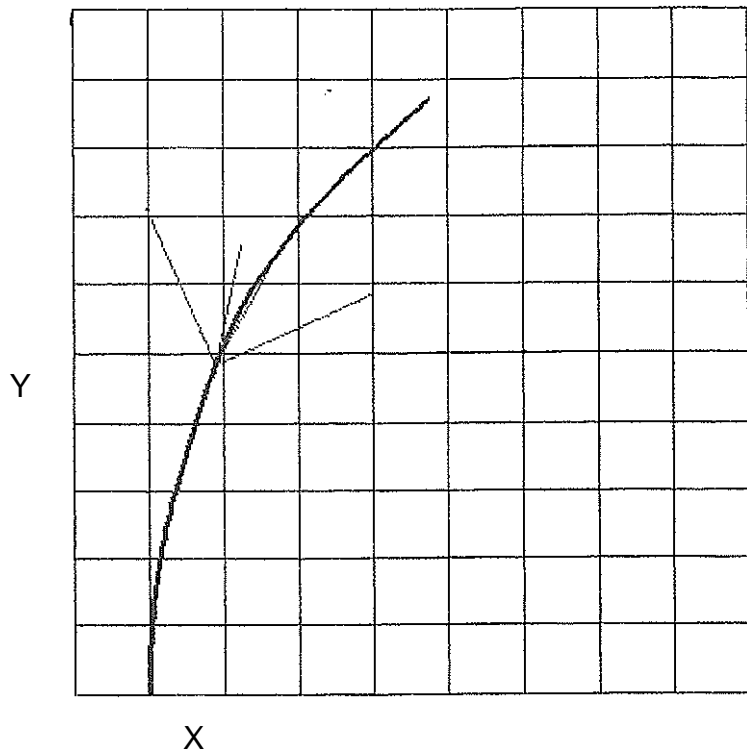

Wind velocity: 40.0 m/s
 $X = 4.13$ m

7. VHF antenna: FAB-151D

Installing the VHF antenna in the way as shown in (a) defective mounting example increases reflection electric power, to which care must be taken.

Reference: Reflection electric power shall be within 10%.

In addition, excessively tightening the antenna mounting brackets deforms the brackets. Mount the antenna with proper brackets.

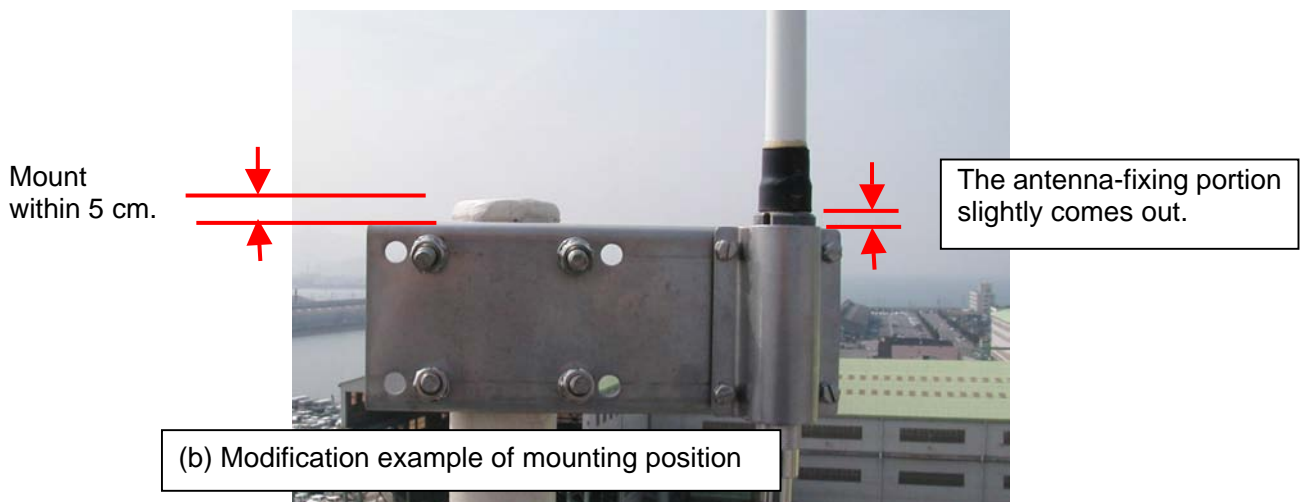
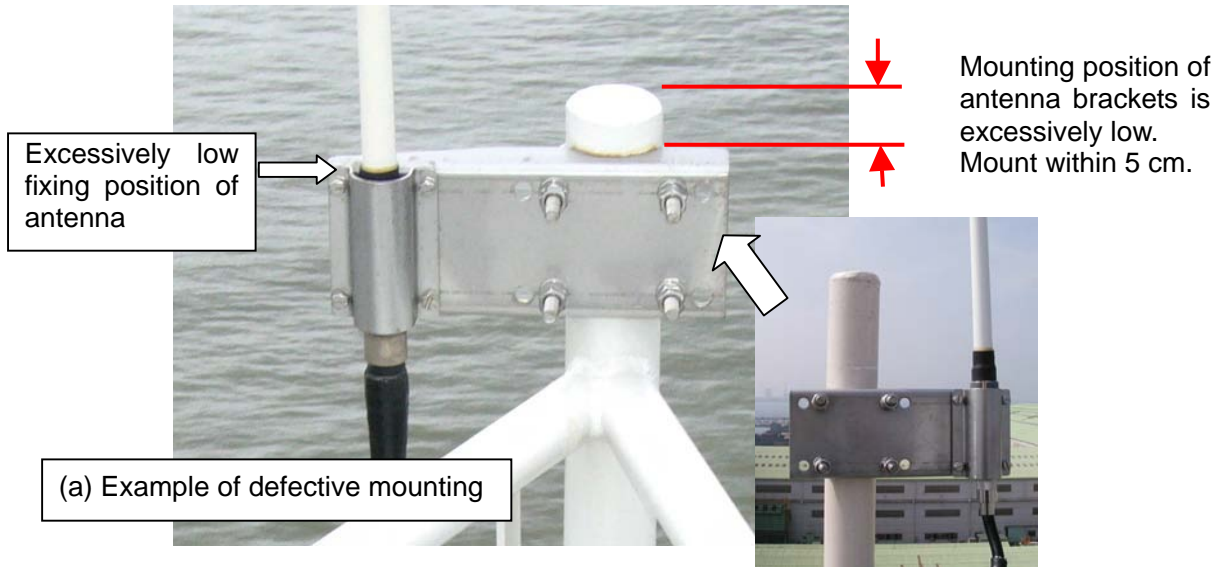

AP2.2.3 Radar antenna

For S-band radar and X-band radar, arrange antenna units in such a manner to avoid beams from each other.

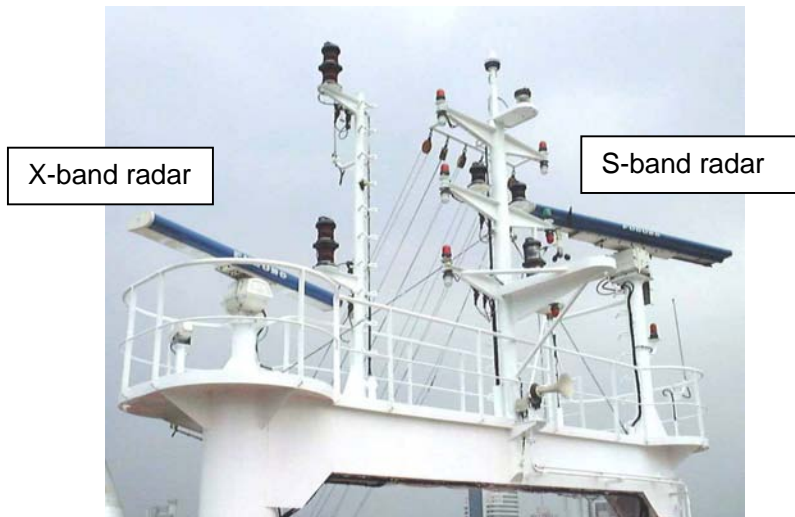
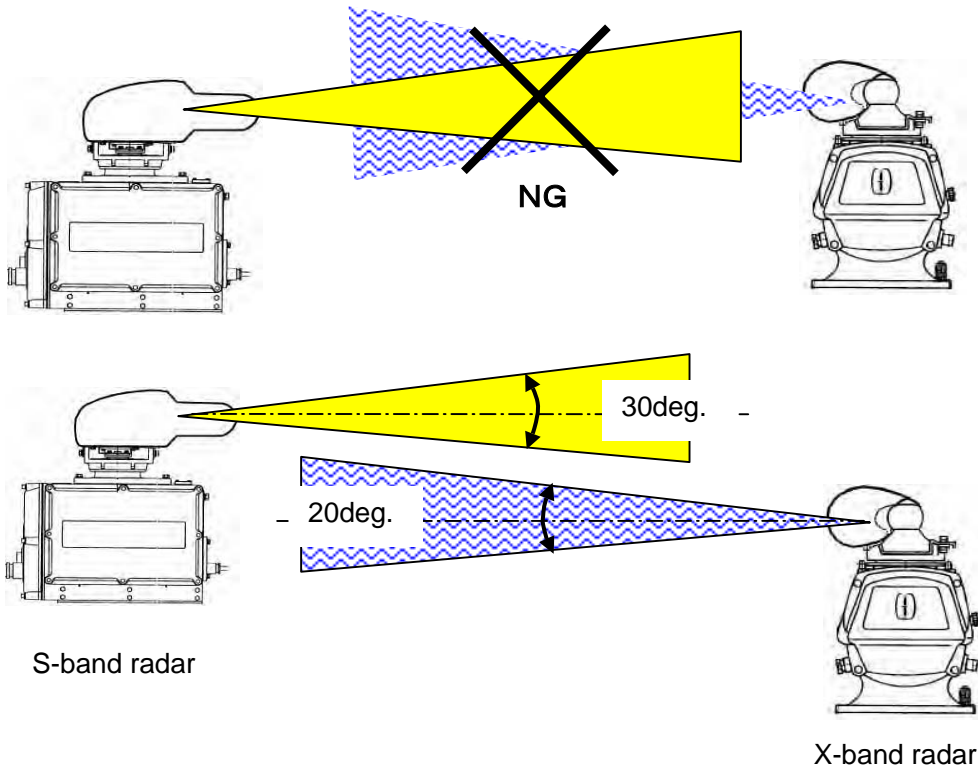

AP2.3 Table of antenna interactions

Table of antenna interactions

	No.1 INMR-C	No.2 INMR-C	INMAR-SSAS	INMAR-B/F	AIS	NAVTEX	MF/HF WR	MF/HF RT	MF/HF Rx	No.1 VHF RT	No.1 VHF WR	No.2 VHF RT	No.2 VHF WR	GPS	S- RADAR	X- RADAR
No.1 INMR-C	--	L=1.5 m H=1 m	L=1.5 m H=1 m	3.5 m	2 m	2 m	2 m	5 m	2 m	2 m	2 m	2 m	2 m	3 m	Beam	Beam
No.2 INMR-C	L=1.5 m H=1 m	--	L=1.5m H=1m	3.5 m	2 m	2 m	2 m	5 m	2 m	2 m	2 m	2 m	2 m	3 m	Beam	Beam
INMAR-SSAS	L=1.5 m H=1 m	L=1.5 m H=1 m	--	3.5 m	2 m	2 m	2 m	5 m	2 m	2 m	2 m	2 m	2 m	3 m	Beam	Beam
INMAR B/F	3.5 m	3.5 m	3.5 m	--	2 m	2 m	2 m	5 m	2 m	2 m	2 m	2 m	2 m	5 m	Beam	Beam
AIS	2 m	2 m	2 m	2 m	--	2 m	2 m	3 m	2 m	H: 10 m or V: 3 m	5 m	H: 10 m or V: 3 m	5 m	1 m	Beam	Beam
NAVTEX Rcv	2 m	2 m	2 m	2 m	2 m	--	1 m	5 m	1 m	2 m	1 m	2 m	1 m	1 m	Beam	Beam
MF/HF WR	2 m	2 m	2 m	2 m	2 m	1 m	--	5 m	1 m	2 m	1 m	2 m	1 m	1 m	Beam	Beam
MF/HF RT	5 m	5 m	5 m	5 m	3 m	5 m	5 m	--	5 m	3 m	3 m	3 m	3 m	4 m	Beam	Beam
MF/HF Rx	2 m	2 m	2 m	2 m	2 m	1 m		5 m	--	2 m	1 m	2 m	1 m	1 m	Beam	Beam
No1VHF RT	2 m	2 m	2 m	2 m	H: 10 m or V: 3 m	2 m	2 m	3 m	2 m	--	5 m	5 m	5 m	1 m	Beam	Beam
No.1 VHF WR	2 m	2 m	2 m	2 m	5 m	1 m	1 m	3 m	1 m	5 m	--	5 m	1 m	1 m	Beam	Beam
No.2 VHF RT	2 m	2 m	2 m	2 m	H: 10 m or V: 3 m	2 m	2 m	3 m	2 m	5 m	5 m	--	5 m	1 m	Beam	Beam
No.2 VHF WR	2 m	2 m	2 m	2 m	5 m	1 m	1 m	3 m	1 m	5 m	1 m	5 m	--	1 m	Beam	Beam
GPS	3 m	3 m	3 m	5 m	1 m	1 m	1 m	4 m	1 m	1 m	1 m	1 m	1 m	--	Beam	Beam
S- RADAR	Beam	Beam	Beam	Beam	Beam	Beam	Beam	Beam	Beam	Beam	Beam	Beam	Beam	Beam	--	Beam
X- RADAR	Beam	Beam	Beam	Beam	Beam	Beam	Beam	Beam	Beam	Beam	Beam	Beam	Beam	Beam	Beam	--

Appendix 3. Radar Waveguide

AP3.1 Waveguide for X-Band Radar



Caution on handling waveguide

Be careful not to deform the waveguide.
衝撃を与えないよう注意して下さい。

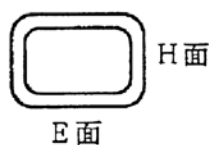
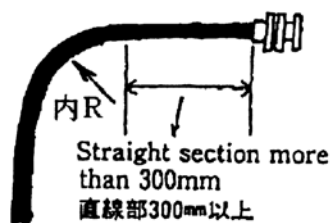
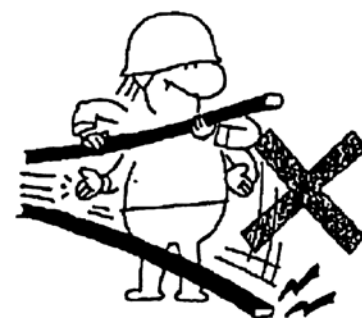
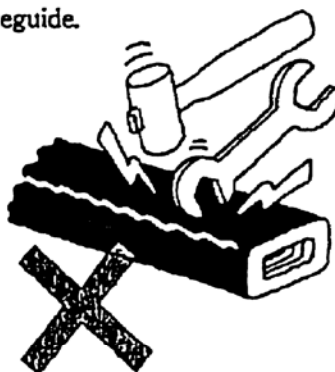

Minimum bending radius

- E bend Rmm = 200 mm
- H bend Rmm = 400 mm

Tools for fabricating X-Band Radar Wave-Guide

If necessary, order these tools to FURUNO.
 Type: OP03-123, Code No. 0084488800



Code No.	Item	Type	Qty.
00015179800	FR-90 power tool	R4KG5549 03S9791-0	1set
10020750000	Edge gauge	03-009-0530-0	1
10020754000	Gauge (Square)	03-009-0534-0	1
00080584700	Tool box	#2207	1
00080584800	Brush	8 inch	1
00080584900	Wrench	For M4	2
00080585000	Hack saw	HFJ-12	1
00080585100	Saw	250 m x 24 mm	6
00080585200	File	L150	1
00080585300	File	L150	1
00080585400	Knife	DK-N	1
00080585500	Heavy duty snips	K30, 190	1 set

Procedure

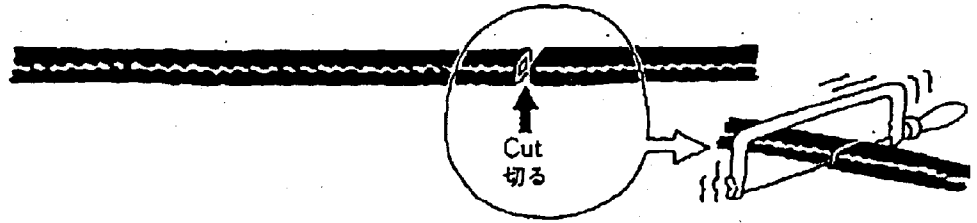

Make sure not to leave scrapings in the waveguide.
導波管の中の切屑を取り除いて下さい。

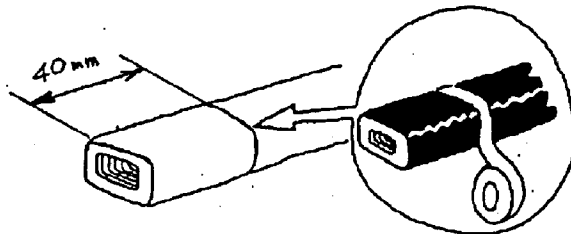
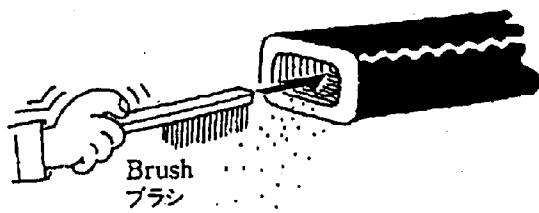

Wind a PVC tape at a part away from the cutting point.
切断位置にビニールテープを巻く。

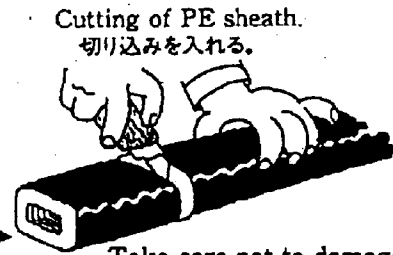

Take care not to damage the conductor with knife.
導管にキズを付けないようご注意ください。

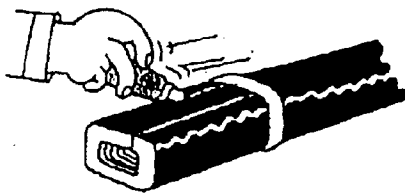

Wipe the compound with cloth.
布ぎれで、コンパウンドをふき取って下さい。

Raise up and remove the sheath.
シースをはぎ取る

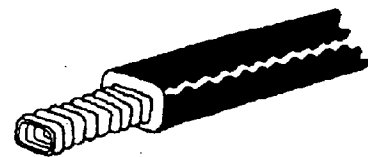
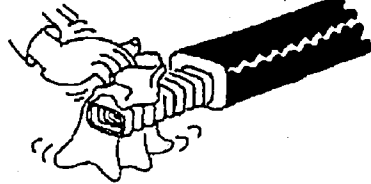
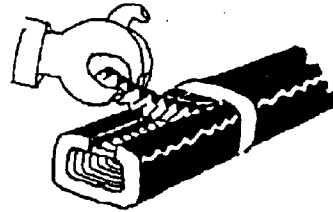

Finish the edge of the conductor with a file.
 導体端部をヤスリで仕上げてください。

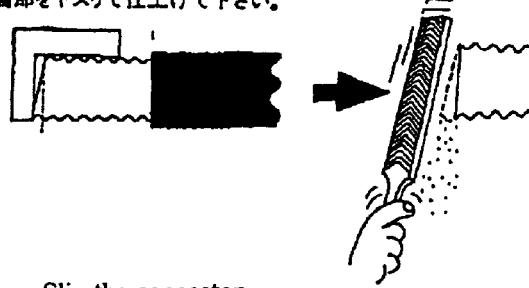

Check the angle
 直角であるかチェックして下さい。

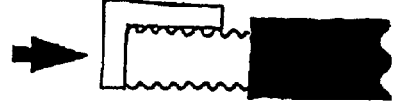

Slip the connector
 コネクタを挿入します。

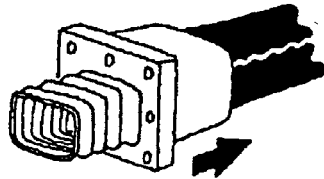

Turn the feed gear counterclockwise and bring flare roller to the center of the holder.
 送りギヤを反時計方向に回して導波管固定用ホルダーの中央に持ってきます。

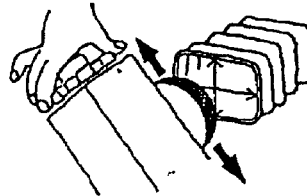

Put forth the conductor one pitch from the end of attachment.
 アタッチメント端面から、導体を1山分出してセッティングします。

アタッチメント端面から、導体を1山分出してセッティングします。

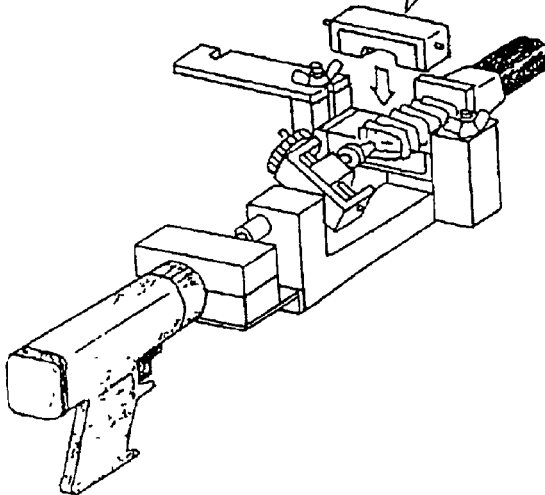
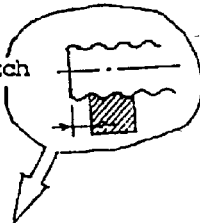

Avoid accidental starting.
 Don't carry tool with finger on switch.

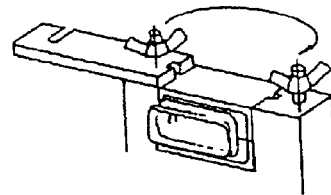

After upper attachment put on the conductor, fix it by metal fittings.

上側のアタッチメントを乗せた後、押さえ金具で固定して下さい。

Apply silicone grease to the end of the flare roller.
シリコングリスを塗ります。

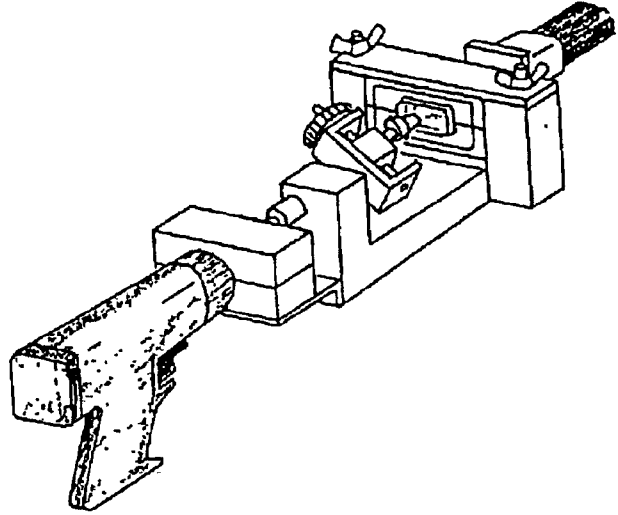
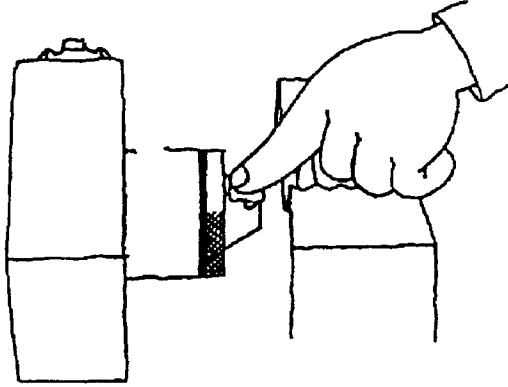

Change the switch to flaring mode(R).

モーター部の取っ手にある回転方向切替スイッチをR方向にして下さい。

Do not touch movable parts or accessories unless the power source has been disconnected.

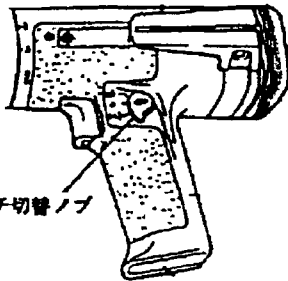

スイッチ切替ノブ

R: flaring mode
L: reverse mode
O: neutral mode

R: フレア加工をする時
L: ローラーを元に戻す時
O: ニュートラル

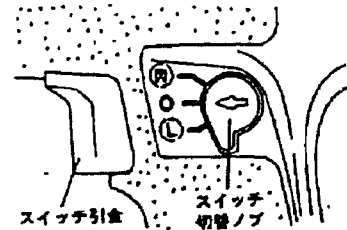

スイッチ引き金

スイッチ切替ノブ

Push the switch, and flaring starts.

スイッチ引き金を押すと回転が始まります。

If give crack, once more /
もし、フレヤー部が割れた場合にはやり直して下さい。

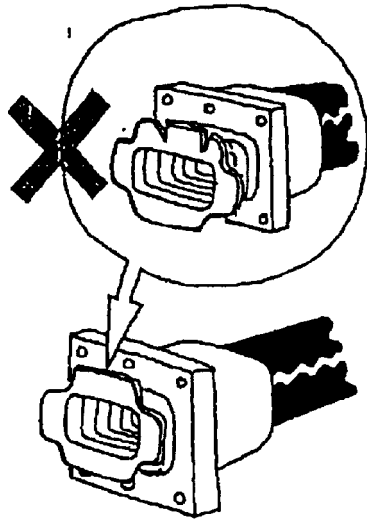

Insert the "edge locating jig" into the waveguide
and finish with scissors and a file.
フチ切り治具を導波管に挿入し、
導体の端部が治具と一致するようにハサミとヤスリで仕上げます。

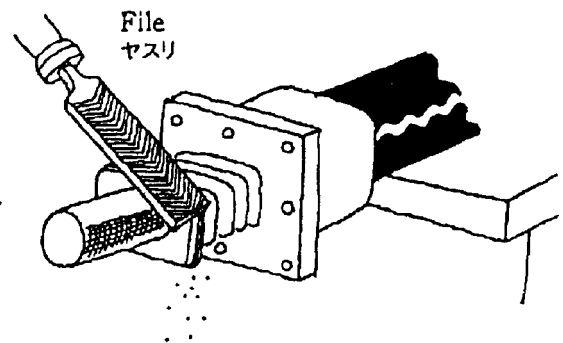
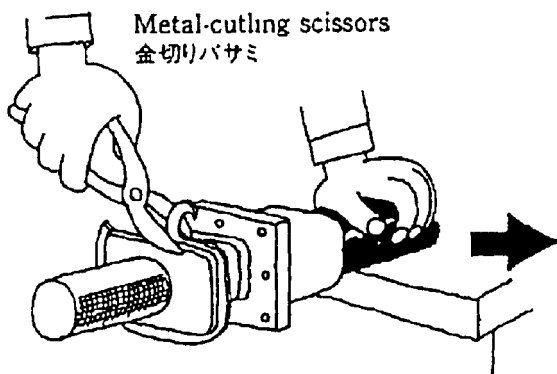
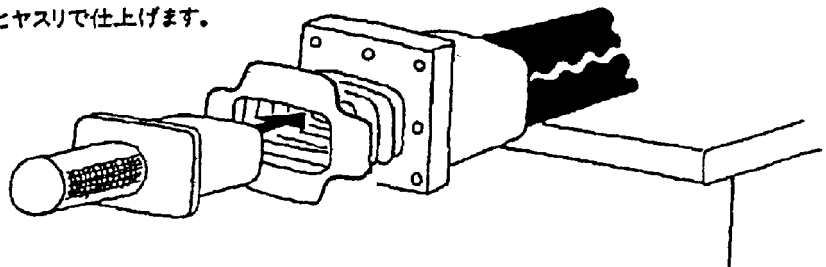

Cleanse well the inner surface of the conductor.
 ブラシで内面をきれいにして下さい。

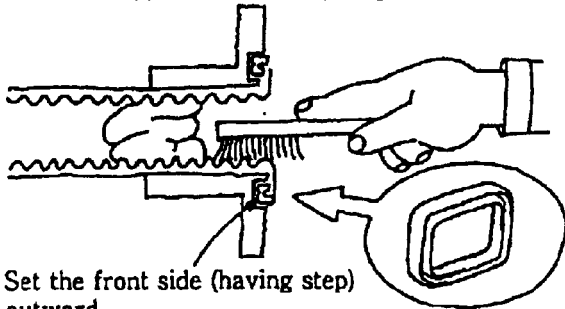

Set the front side (having step) outward.
 パッキンに裏表があります、ご注意ください。

Set the conductor in the center of groove of the gasket.
 パッキンの溝の中央に導波管の切り口を合わせて下さい。

Take off the cloth.
 布きれを取り出して下さい。

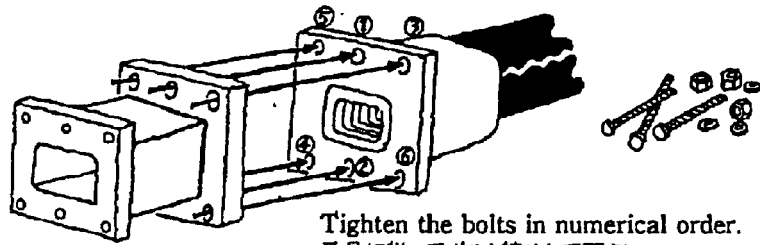
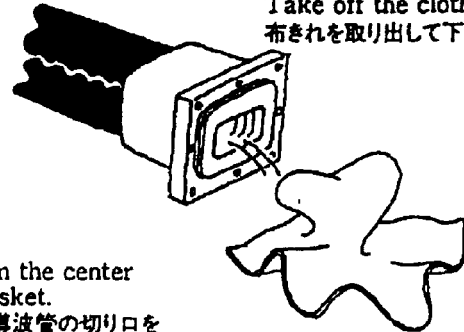

Tighten the bolts in numerical order.
 番号に従ってボルト締めして下さい。

Pouring of sealing compound.
 シーリングコンパウンドを注入します。

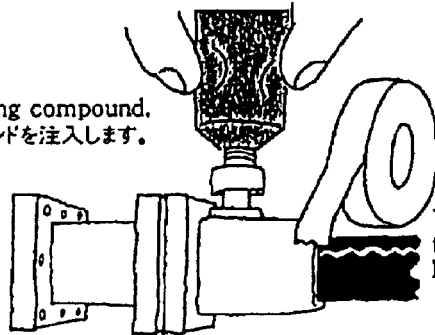

Wind the self-bonding tape (FCO tape) between the ends of the connector and PE sheath, half-lapped in two layers.
 自己融着テープ(エフコテープ)で半ラップ2層巻きます。

Further, wind PVC tape half-lapped in two layers
 That is the end of the treatment.
 更に、この上にPVCテープを半ラップ2層巻きます。これで完了です。

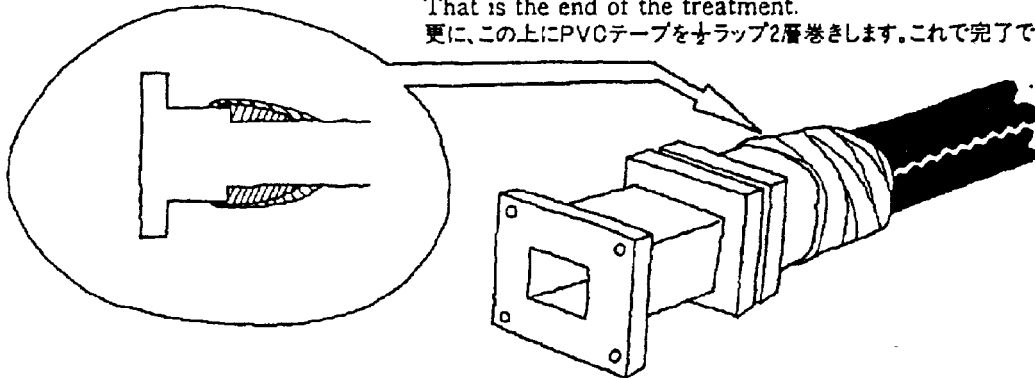

AP3.2 Waveguide for S-Band Radar

High frequency Coaxial cable

The scanner unit is connected to the transceiver unit by a high frequency coaxial cable. It is necessary to install the connector at the transceiver side of the coaxial cable. The connector for the scanner unit side has been installed in the factory.

Installing coaxial cable

Use the cable band for fixing the cable supplied.



The cable band Fig. AP3.2.1 (Type: 03-011-3228, Code: 100-049-62) is also available optionally.

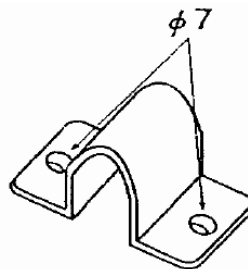
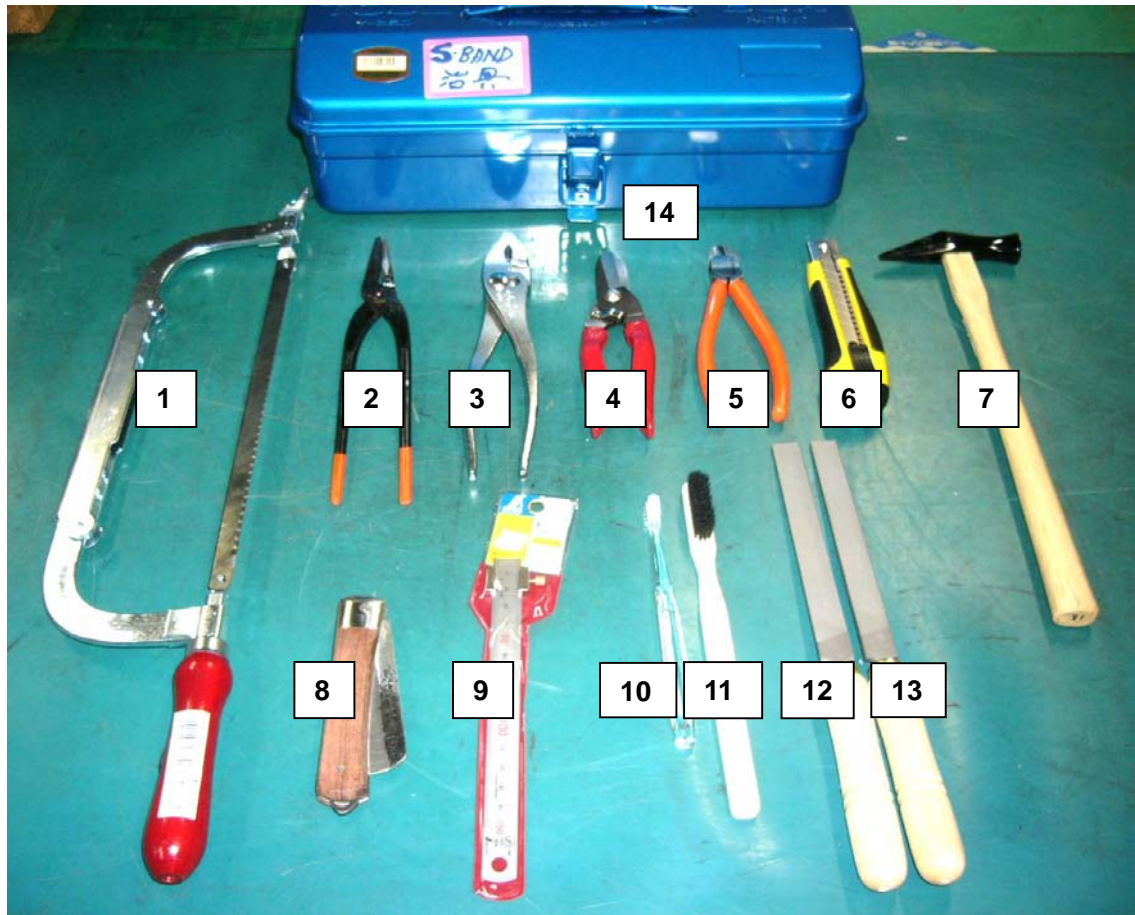

Fig. AP3.2.1 Cable band, optional

Necessary tools



No.	Name	Type	No.	Name	Type
1	Hack-saw	HFJ-12	8	Knife	DK-N
2	Pincers	220 mm	9	Bench rule with stopper	150 mm
3	Plier	PL-200	10	Brush	Small
4	Snips	170 mm	11	Brush	Medium
5	Nipper	70-150	12	File	Fine
6	Knife	LDS-20-028	13	File	Second -cut
7	Hammer	18 mm	14	Tool Box	Y-350

Installation Material

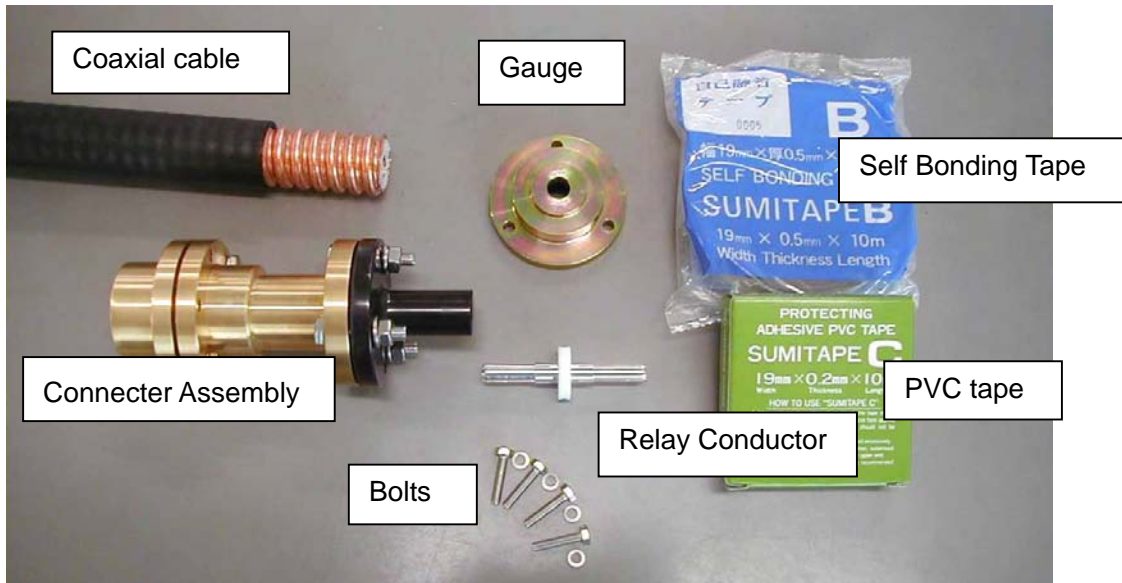

Note1: Prevent foreign substances from being entered into the cable during the work.

Note2: A minimum cable bending radius of 150 mm must be observed at the cable run. When bending the cable twice or more in close points, the bending radius should be more than 250 mm.

Procedure

1. Straighten the cable and cut it with using the hacksaw and scale (gauge).

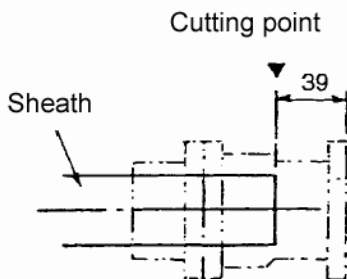

2. Remove the sheath 40 mm with using the tubing cutter and scale.
Note: Be careful not to nick the outer conductor.



3. Remove the outer conductor and the insulator. (Tools: Hacksaw and scale)



4. Removing burr of the outer conductor with the file.
5. Remove the insulator in the outer conductor 6 mm.

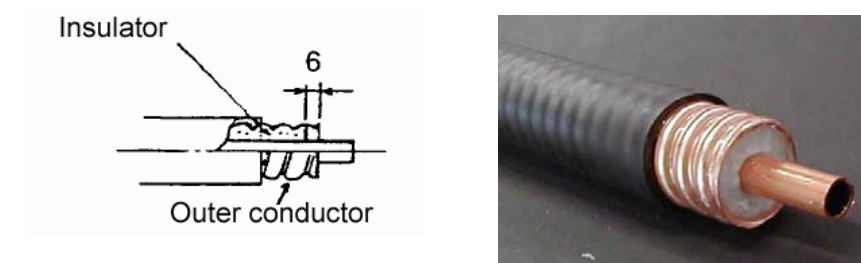

6. Connect the connector to the coaxial cable. Screw connector onto the coaxial cable.

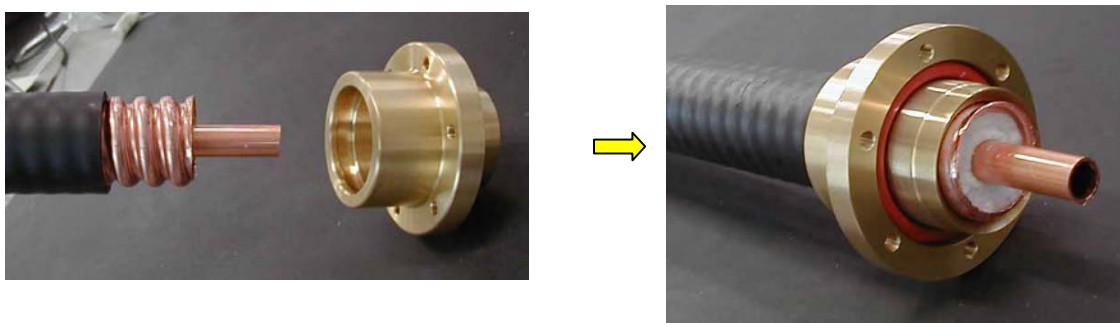

7. Flare the outer conductor along the connector by the pincers.
8. File the outer conductor beyond the diameter of the connector.

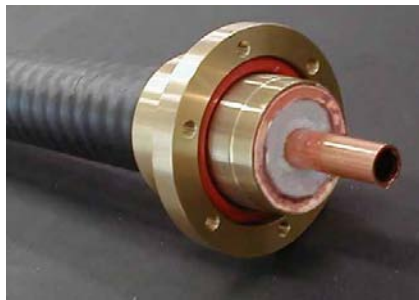
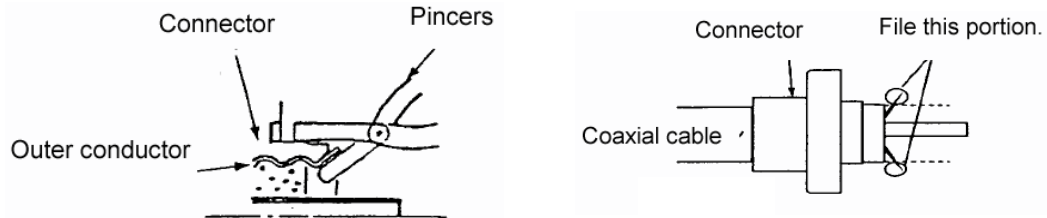

9. Insert the gauge through the connector. Fix the gauge by the bolts, and then cut the inner conductor leaving 1 mm for finishing. (Tools: Gauge, M4 Wrench and Hacksaw)

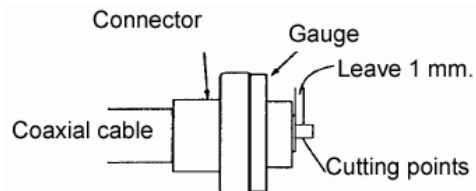

10. Remove the gauge.

Then, file the inner conductor to finish.



11. Assemble the relay connector and the relay conductor, and then connect it to the coaxial cable.

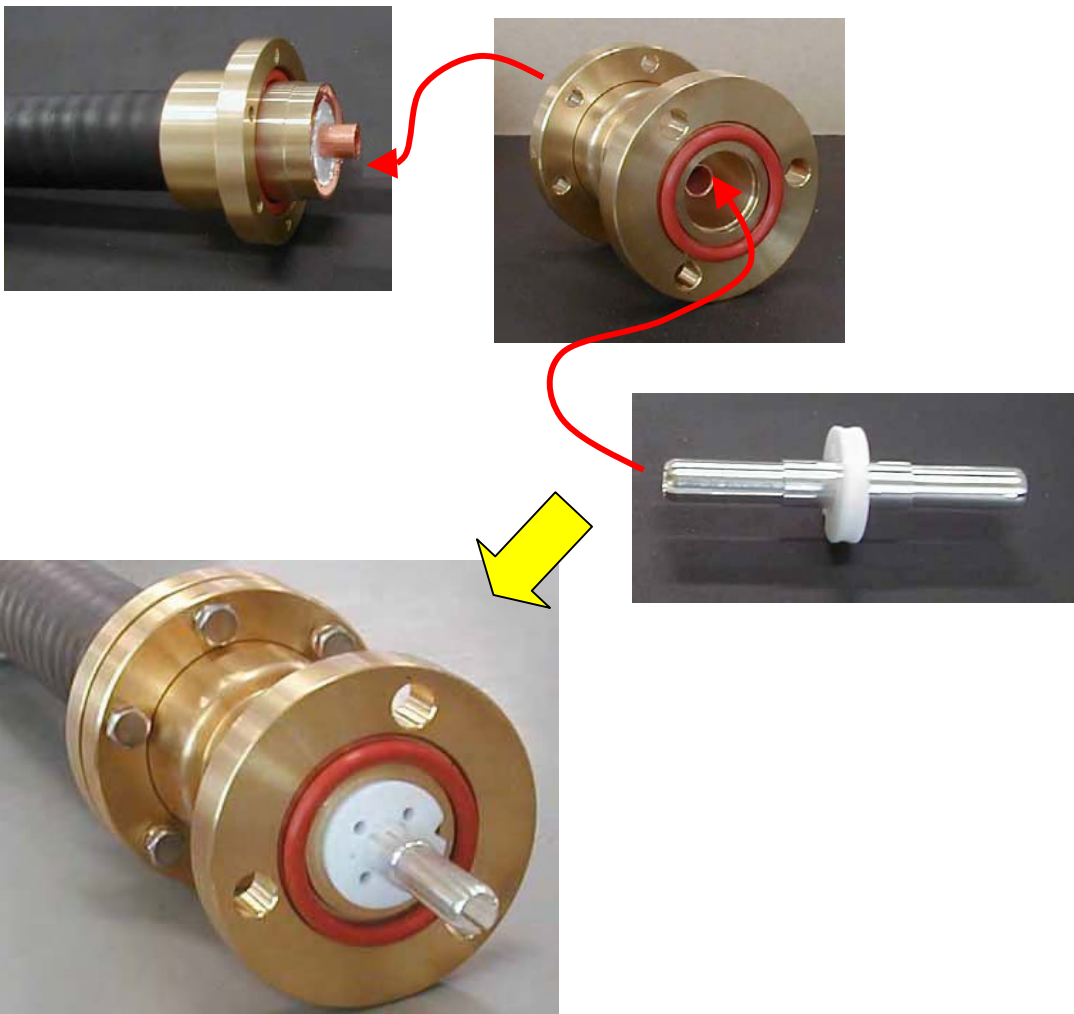

12. Tape the self-bonding tape twice or more on the cable and connector. And then, tape the PVC tape over the self-bonding.

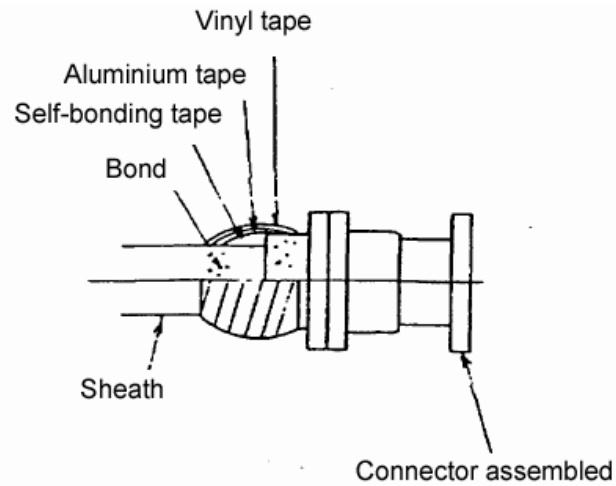

AP4.1 Power cable

- Loss of the ship’s main voltage caused by the supply cable.
- Generally, tolerance of the power supply voltage for navigational equipment must be within +/-10 % of the standard voltage.
- Since the voltage decreases in accordance with the length and thickness of cable, the type of the cable must be determined so as to keep the voltage within this range.
- Generally, the type of cable is selected so that the decrease of voltage is limited within 3 to 5 % of the standard voltage.

4.1.1 Voltage drop

The voltage “Vd” decreased by the cable is given by the following equation;

$$Vd = K i r L / 1000$$

K: Coefficient

Single phase AC and DC voltage: 2

Three phase AC: square root of 3

i: Current flow in cable (A)

r: resistance of cable (ohm/km)

L: length of cable

Maximum Cable length

$$L = 1000 Vd / K i r$$

Resistance of the cable (ohm/km)

Type	Nominal area (mm ²)	Number of wires/diameter of each wire (mm)	Resistance of cable (ohm/km)
DPYC-1.5	1.5	7/0.52	12.1
DPYC-2.5	2.5	7/0.67	7.41
DPYC-4	4.0	7/0.85	4.61
DPYC-6	6.0	7/1.04	3.08
DPYC-10	10.0	7/1.35	1.83
DPYC-16	16.0	7/1.70	1.15
DPYC-25	25.0	7/2.14	0.73
DPYC-35	35.0	7/2.52	0.52
DPYC-50	50.0	19/1.78	0.39

Example 1: VHF radio (24 VDC)

When the cable type is DPYC-6 (6 mm², r = 3.08 ohm/km) and transmission current is 7 A, the cable length which decreases the voltage to 3 % of standard voltage (24 V), is 16.7 m.

$$V_d = 24 \times 0.03 = 0.72 \text{ V}$$

$$L = (1000 \times 0.72) / (2 \times 7 \times 3.08) = 16.7 \text{ m.}$$

If the longer cable is required, Type DPYC-10 or thicker one is appropriate.

Example 2: Cable for battery (back up: 24 VDC)

When the cable type is DPYC-35 (35 mm², r = 0.524 ohm/km) and consumption of current is 50 A, the cable length which decrease the voltage to 5 % of standard voltage (24VDC), is 22.9 m.

$$V_d = 24 \times 0.05 = 1.2 \text{ V}$$

$$L = (1000 \times 1.2) / (2 \times 50 \times 0.524) = 22.9 \text{ m}$$

If the longer cable is required, Type DPYC-50 or thicker one is appropriate.

Example 3: PR-850A (AC/DC Power supply)

When the cable type is the DPYC-4 (4 mm², r = 4.61 ohm/km) and current consumption is 7 A (220 VAC), the cable length which decrease the voltage to 5 % of standard voltage (220VAC) is 170 m.

$$V_d = 220 \times 0.05 = 11 \text{ V}$$

$$L = (1000 \times 11) / (2 \times 7 \times 4.61) = 170 \text{ m}$$

If the longer cable is required, Type DPYC-6 or thicker one is appropriate.

Current vs. Maximum cable length

Fig. AP4.1.1 shows the maximum cable length versus current in order to keep the voltage drop within 5 % when power supply is 24 VDC.

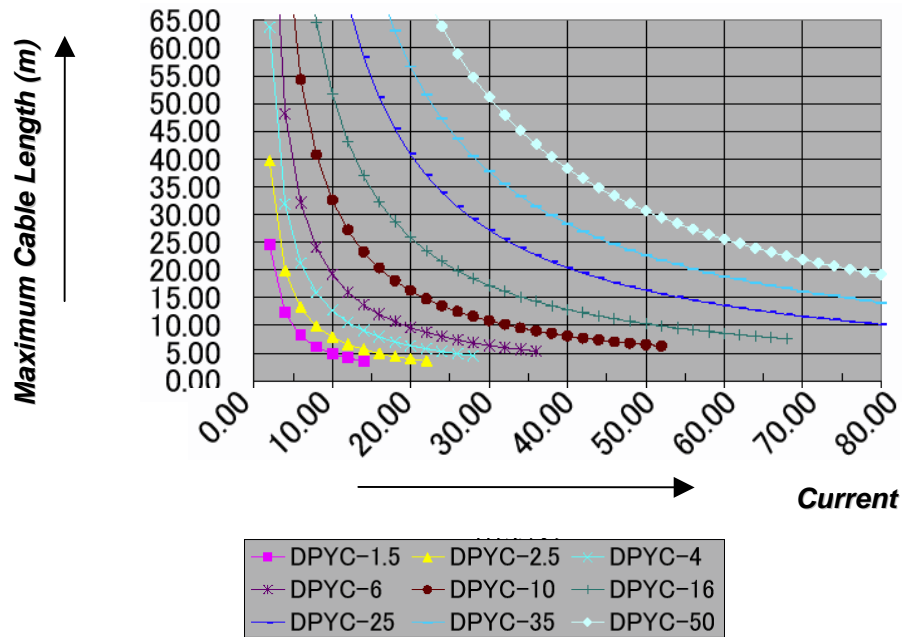

Diameter of wire	DPYC									
	1.5	2.5	4	6	10	16	25	35	50	70
Conductor resistance (Ohm/km) at 20°C	12.2	7.56	4.7	3.11	1.84	1.16	0.734	0.529	0.391	0.27

Fig. AP4.1.1 Current vs. maximum cable length

The following tables show the relation among voltage drop of load current and cable length in accordance with the cable type.

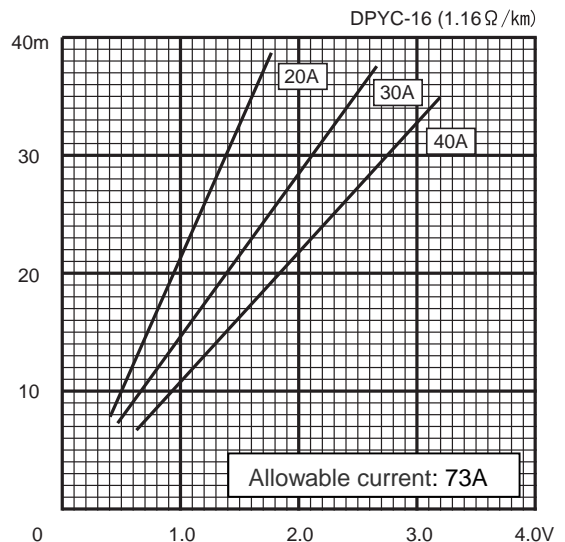
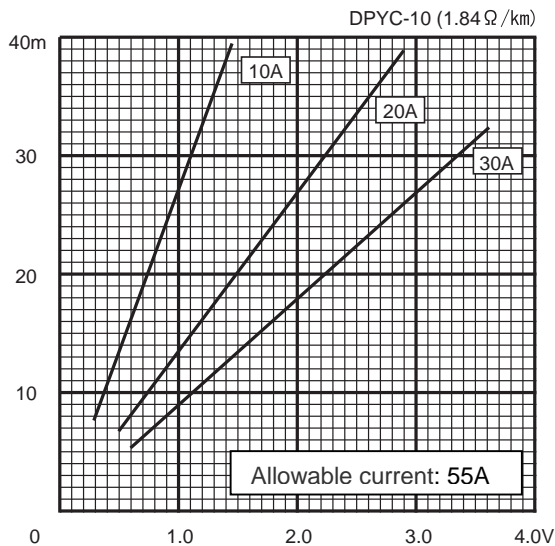
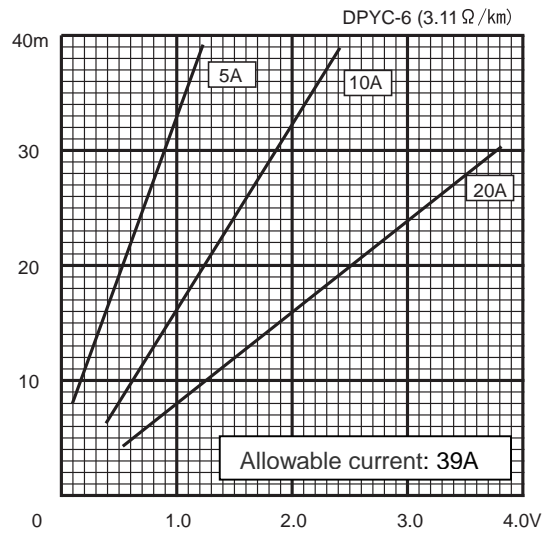
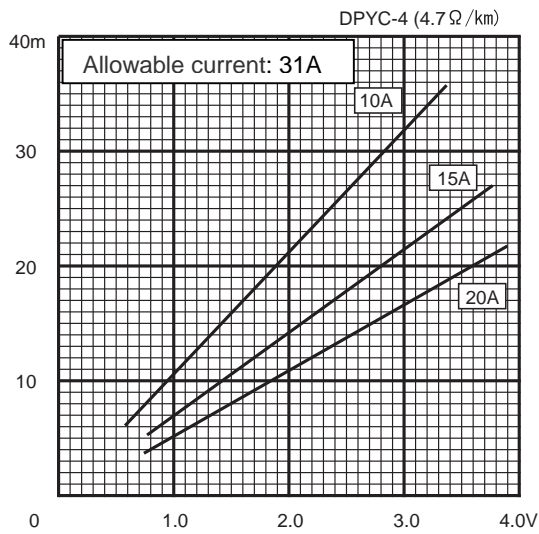
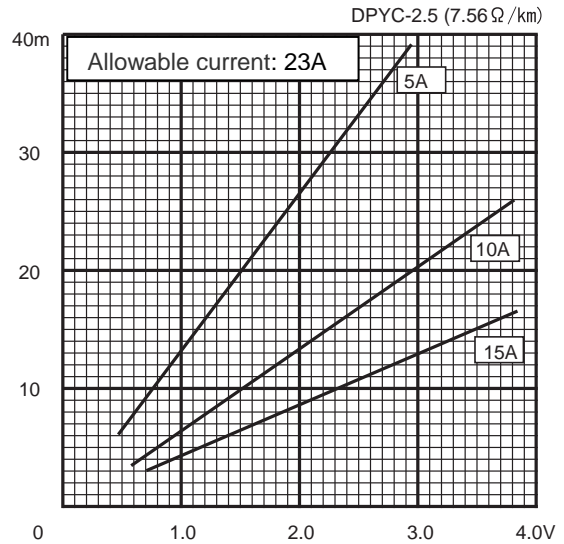
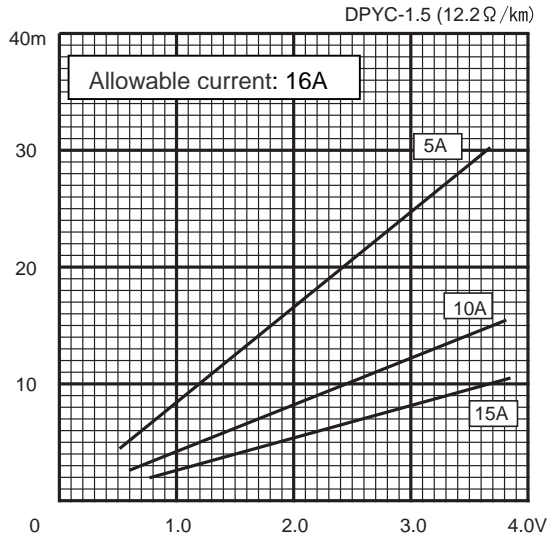

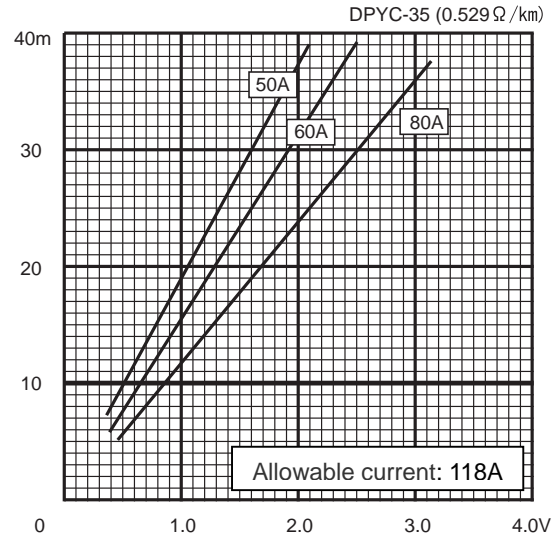
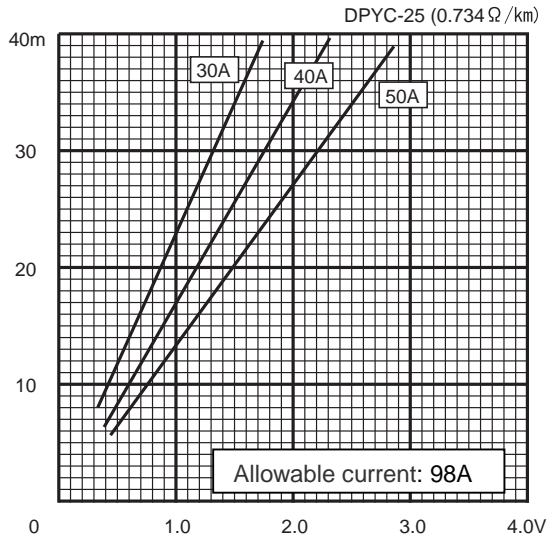

DPY/DPYC/DPYCY cables.

Nominal cross-sectional area (mm ²)	Wire number/ Diameter (mm)	Outer diameter of wire	DPY Outer diameter (mm)	DPYC Outer diameter fin. (mm)	DPYCY Outer diameter fin. (mm)	Conductor resistance without plating (Ohm/km)	Conductor resistance with plating (Ohm/km)	Test voltage (V)	Insulation resistance (M Ohm km)
1.5	7/0.52	1.56	10.4	11.7	13.7	12.1	12.2	3500	1300
2.5	7/0.67	2.01	11.5	12.8	14.8	7.41	7.56		1100
4	7/0.85	2.55	12.6	13.9	15.9	4.61	4.70		900
6	7/1.04	3.12	13.9	15.2	17.4	3.08	3.11		800
10	7/1.35	4.05	15.8	17.1	19.3	1.83	1.84		700
16	7/1.70	5.10	18.1	19.4	21.8	1.15	1.16		600
25	7/2.14	6.42	21.7	23.0	25.6	0.727	0.734		500
35	7/2.52	7.56	24.2	25.5	28.1	0.524	0.529		450
50	19/1.78	8.90	28.1	29.4	32.2	0.387	0.391		450
70	19/2.14	10.7	33.3	35.1	38.5	0.268	0.270		450

MPY/MPYC/MPYCY cables.

Number of conductor	Nominal cross-sectional area (mm ²)	Wire number/ Diameter (mm)	Outer diameter of wire	MPY Outer diameter (mm)	MPYC Outer diameter fin. (mm)	MPYCY Outer diameter fin. (mm)	Conductor resistance without plating (Ohm/km)	Conductor resistance with plating (Ohm/km)	Test voltage (V)	Insulation resistance (M Ohm km)
2	1	7/0.43	1.29	8.7	10	12.0	18.1	18.2	1500	1200
4				9.9	11.2	13.2				
7				11.9	13.2	15.2				
12				15.5	16.8	19.0				
19				18.3	19.6	22.0				
27				22.1	23.4	26.0				
37				24.8	26.1	28.9				
44				28.0	29.3	32.1				
77				35.9	37.7	41.0				

MPYCS/MPYCYS Cables

Number of conductor	Nominal cross-sectional area (mm ²)	Wire number/Diameter (mm)	Outer diameter of wire	MPYCS Outer diameter fin. (mm)	MPYCYS Outer diameter fin. (mm)	Conductor resistance without plating (Ω/km)	Conductor resistance with plating (Ω/km)	Test voltage (V)	Insulation resistance (M Ohm km)
2	1	7/0.43	1.29	10.7	12.7	18.1	18.2	1500	1200
4				11.9	13.9				
7				13.9	15.9				
12				17.6	19.8				
19				20.6	23.0				
27				24.3	26.9				
37				27.0	29.8				
44				30.2	33.2				

TTY/TTYC/TTYCY cable.

Pair	Number of wire	Nominal cross-sectional area (mm ²)	Wire number/Diameter (mm)	Outer diameter of wire	TTY Outer diameter fin. (mm)	TTYC Outer diameter fin. (mm)	TTYCY Outer diameter fin. (mm)	Conductor resistance (Ohm/km)	Test voltage (V)	Insulation resistance (M Ohm km)
1	2	0.75	7/0.37	1.11	7.9	9.2	11.0	26.0	1500	300
1T	3				8.6	9.9	11.7			
1Q	4				9.3	10.6	12.6			
4	8				14.2	15.5	17.7			
7	14				16.9	18.2	20.6			
10	20				21.7	23.0	25.6			
14	28				23.5	24.8	27.4			
19	38				26.4	27.7	30.5			

TTYCS/TTYCYS Cables with shield.

Pair	Number of wire	Nominal cross-sectional area (mm ²)	Wire number/Diameter (mm)	Outer diameter of wire	TTYCS Outer diameter fin. (mm)	TTYCYS Outer diameter fin. (mm)	Conductor resistance (Ohm/km)	Test voltage (V)	Insulation resistance (M Ohm km)
1	2	0.75	7/0.37	1.11	10.1	12.1	26.0	1500	300
1T	3				10.6	12.6			
1Q	4				11.3	13.3			
4	8				16.3	18.5			
7	14				19.0	21.4			
10	20				24.0	26.7			
14	28				25.7	28.3			
19	38				28.8	31.6			



AP4.2 Coaxial cable

When the coaxial cable type is selected, the decrease of RF signal loss is recommend within 3 dB around.

For example, if the VHF antenna coaxial cable is RG-10/U and the cable length is 30 m, the loss of 2.4 dB is resulted. In this case, antenna input power is decreased from 25 W to 14 W around. The receiving sensitivity is also decreased.

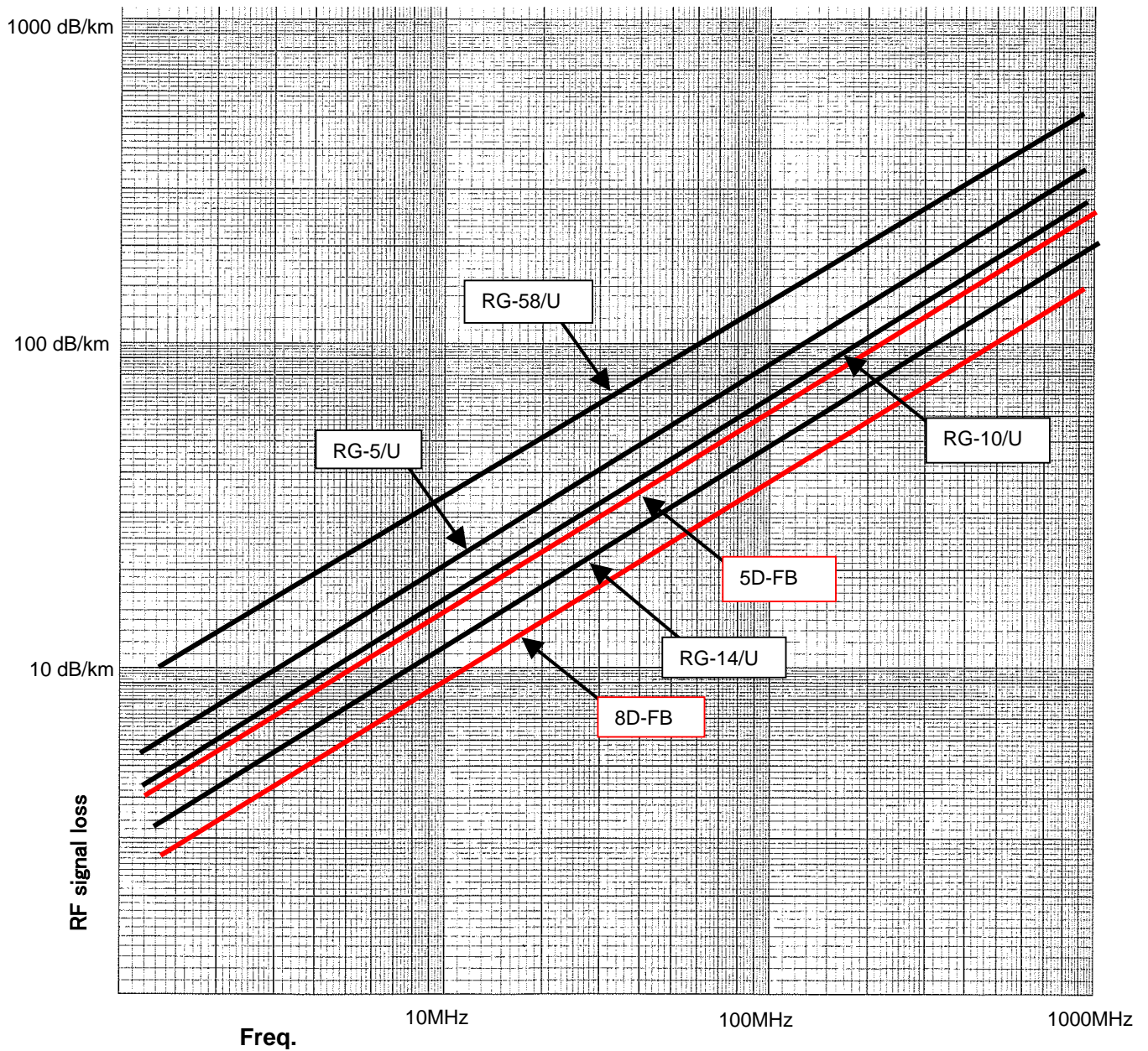

AP4.2.1 Using Coaxial cable list

Equipment	Type	Freq, Range	Remarks
Inmarsat B	FELCOM 82	1.5/1.6 GHz	30 m: 8D-FB-CV 50 m: 8D-FB-CV 100 m: 12D-SFA-CV
Inmarsat C	FELCOM 15	1.5/1.6 GHz	30 m: TP5FBAW-5DFBB 50 m: 8D-FB-CV 100 m: 12D-SFA-CV
	FELCOM 16	1.5/1.6 GHz	15 m: TP58A15W-RG58 30 m: TP5FBAW-5DFBB 50 m: 8D-FB-CV 100 m: 12D-SFA-CV
Inmarsat F	FELCOM 70	1.5/1.6 GHz	30/40/50/60 m: 8D-FB-CV 100 m: 12D-SFA-CV
MF/HF Radio	FS-5000	1.6 ~30 MHz	50 m: RG-8A/U, or RG-10/UY
	FS-1570/2570	1.6 to 30 MHz	50 m: RG-10/UY or 50 m: 05S0462(5D-2V)
MF/HF W/R	Built-in FS-1570/2570	2/4/6/8/12/ 18/22/25 MHz	15 m: FAX-5 (3D-2V) 50 m: RG-10/UY
VHF Radio	FM-8800S/D	150/160 MHz	40 m: RG-10/UY 100 m: 8D-FB-CV
VHF WR	Built-in FM-8800S/D	156.725 MHz	40 m: RG-10/UY 100 m: 8D-FB-CV
AIS	FA-150	150/160 MHz	20 m: RG-10/UY 30 m: 8D-FB-CV 50 m: 8D-FB-CV
NAVTEX	NX-700	518 kHz, 490 kHz, 4209.5 kHz	50 m: NX-7 (3D-2V) 50 m: RG-10/UY 200 m: RG-214
GPS	GP-90	1575.42 MHz	15 m: TNC-PS-3D-15 30 m: 8D-FB-CV 50 m: 8D-FB-CV
FAX Receiver	FAX-215	80 to 160 kHz 2 to 25 MHz	15 m: FAX-5 (3D-2V) 50 m: RG-10/UY
All band Receiver		0.1 to 30 MHz	50 m: RG-10/UY

AP4.2.2 decibel (dB)

The decibel (dB) is a measure of the ratio between two quantities, and is used in a wide variety of measurements in acoustics, physics and electronics. While originally only used for power and intensity ratios, it has come to be used more generally in engineering. Decibels are useful because they allow even very large or small ratios to be represented with a conveniently small number (similar to scientific notation). This is achieved by using a logarithm.

Substituting a measured voltage and a reference voltage and rearranging terms leads to the following equations and accounts for the difference between the multiplier of 10 for intensity or power and 20 for voltage:

$$\begin{aligned}
 \text{PdB} &= 10\log(P_x/P_0) \\
 \text{PdB} &= 10\log(V_x^2/R_x / V_o^2/R_o) \rightarrow \text{VdB} = 20 \log(V_x^2/V_o^2)
 \end{aligned}$$

Where V_o are a specified reference voltage. This means a 20 dB increase for every factor 10 increase in the voltage, or approximately 6 dB increase for every factor 2.

Note that in physics, decibels refer to power ratios only; it is incorrect to use them if the electrical impedances are not the same at the two points where the voltage is measured, though this usage is very common in engineering.

For example, dBm is an abbreviation for the power ratio in decibel (dB) of the measured power referenced to one milliwatt (mW).

- dBm (N dBm=10log₁₀P/1mW)
dB(mW): power relative to 1 milliwatt.
- dBμ or dBu (N dBμ=20log₁₀V/1μV)
dB(μV/m): electric field strength relative to 1 microvolt per metre.
- dBW (N dBW=10log₁₀P/1W)
dB(W): power relative to 1 watt.

Substituting table of dB

dB		Amplitude ratio	Attenuation ratio	dB		Amplitude ratio	Attenuation ratio
Volt/Curre	Power			Volt/Curre	Power		
1	0.5	1.122	0.891	51	25.5	355.	0.00282
2	1.0	1.259	0.794	52	26.0	399.	0.00251
3	1.5	1.413	0.708	53	26.5	447.	0.00224
4	2.0	1.585	0.631	54	27.0	501.	0.00200
5	2.5	1.778	0.562	55	27.5	562.	0.00178
6	3.0	1.995	0.501	56	28.0	631.	0.00158
7	3.5	2.24	0.447	57	28.5	708.	0.00141
8	4.0	2.51	0.398	58	29.0	794.	0.00126
9	4.5	2.82	0.355	59	29.5	891.	0.00112
10	5.0	3.16	0.316	60	30.0	1000.	0.00100
11	5.5	3.55	0.282	61	30.5	1120.	0.000891
12	6.0	3.98	0.251	62	31.0	1260.	0.000794
13	6.5	4.47	0.224	63	31.5	1410.	0.000708
14	7.0	5.01	0.200	64	32.0	1580.	0.000631
15	7.5	5.62	0.178	65	32.5	1780.	0.000562
16	8.0	6.31	0.158	66	33.0	2000.	0.000501
17	8.5	7.08	0.141	67	33.5	2240.	0.000447
18	9.0	7.94	0.126	68	34.0	2510.	0.000398
19	9.5	8.91	0.112	69	34.5	2820.	0.000355
20	10.0	10.0	0.100	70	35.0	3160.	0.000316
21	10.5	11.2	0.0891	71	35.5	3550.	0.000282
22	11.0	12.6	0.0794	72	36.0	3980.	0.000251
23	11.5	14.1	0.0708	73	36.5	4470.	0.000224
24	12.0	15.8	0.0631	74	37.0	5010.	0.000200
25	12.5	17.8	0.0562	75	37.5	5620.	0.000178
26	13.0	20.0	0.0501	76	38.0	6310.	0.000158
27	13.5	22.4	0.0447	77	38.5	7080.	0.000141
28	14.0	25.1	0.0398	78	39.0	7940.	0.000126
29	14.5	28.2	0.0355	79	39.5	8910.	0.000112
30	15.0	31.6	0.0316	80	40.0	10000.	0.000100
31	15.5	35.5	0.0282	81	40.5	11200.	0.0000891
32	16.0	39.8	0.0251	82	41.0	12600.	0.0000794
33	16.5	44.7	0.0224	83	41.5	14100.	0.0000708
33	17.0	50.1	0.0200	84	42.0	15800.	0.0000631
35	17.5	56.2	0.0178	85	42.5	17800.	0.0000562
36	18.0	63.1	0.0158	86	43.0	20000.	0.0000501
37	18.5	70.8	0.0141	87	43.5	22400.	0.0000447
38	19.0	79.4	0.0126	88	44.0	25100.	0.0000398
39	19.5	89.1	0.0112	89	44.5	28200.	0.0000355
40	20.0	100.0	0.0100	90	45.0	31600.	0.0000316
41	20.5	112.0	0.00891	91	45.5	35500.	0.0000282
42	21.0	126.0	0.00794	92	46.0	39800.	0.0000251
43	21.5	141.0	0.00708	93	46.5	44700.	0.0000224
44	22.0	158.0	0.00631	94	47.0	50100.	0.0000200
45	22.5	178.0	0.00562	95	47.5	56200.	0.0000178
46	23.0	200.0	0.00501	96	48.0	63100.	0.0000158
47	23.5	224.0	0.00447	97	48.5	70800.	0.0000141
48	24.0	251.0	0.00398	98	49.0	79400.	0.0000126
49	24.5	282.0	0.00355	99	49.5	89100.	0.0000112
50	25.0	316.0	0.00316	100	50.0	100000.	0.0000100

AP5.1 Cable Termination

AP5.1.1 Fixing crimp-on lug

- 1) Use a crimper for correct gauge.
- 2) Use the proper size terminal for the wire.

Tools (Example)

Tool	Model	Manufacturer	Photo
Insulated terminal crimper	MH-112	Minoru Kogyo	1
Insulated terminal crimper	CR1MPCX 34S	Izumi	2
Non-insulated terminal crimper	P-75	Hozan	3



Procedure:

1. Remove the armor, and tape the end of the armor.
2. Remove the inner sheath without cutting inner wires.

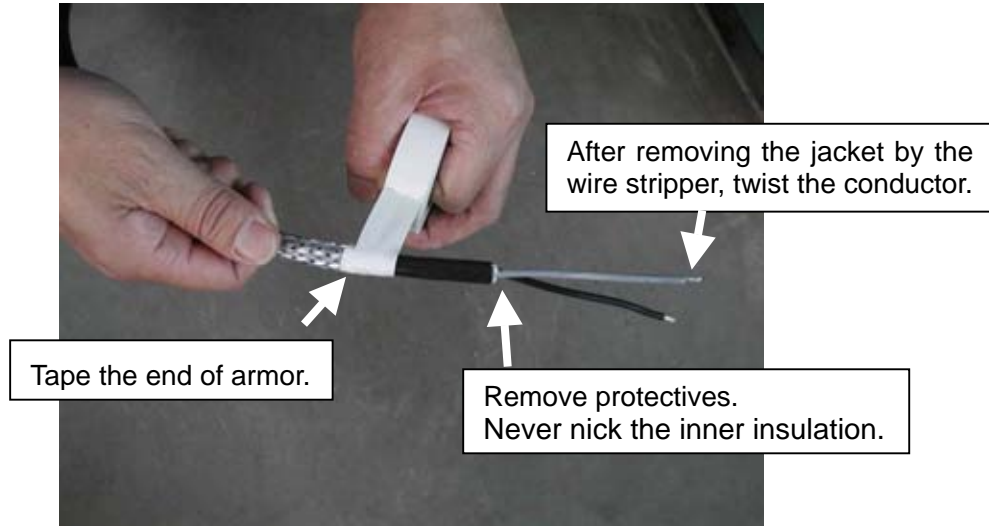

3. Crimping on lug

The jacket length to be removed is $(l + 1)$ mm.

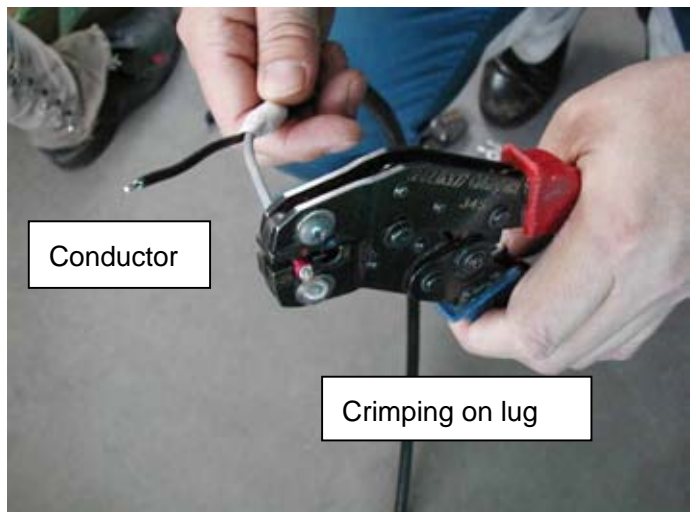
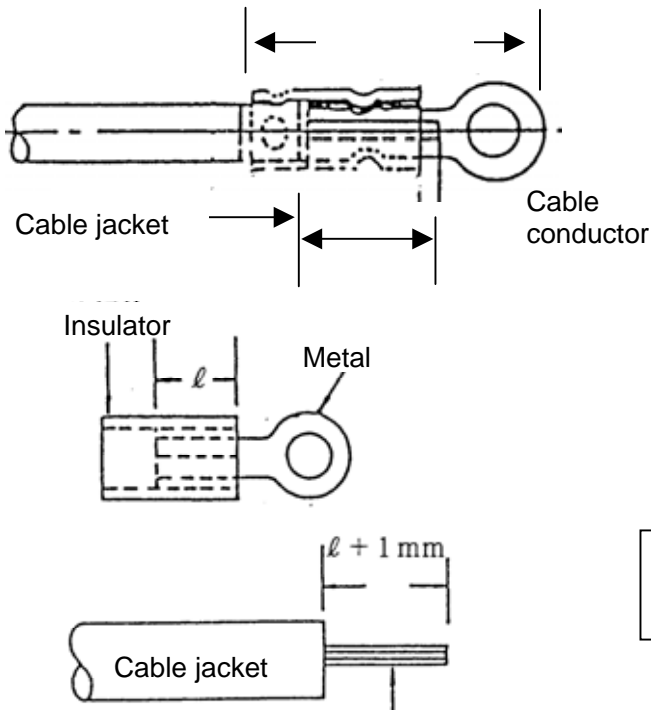

When crimping a lug on the coaxial cable, fold back the conductor.

4. Finishing

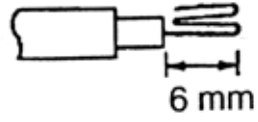

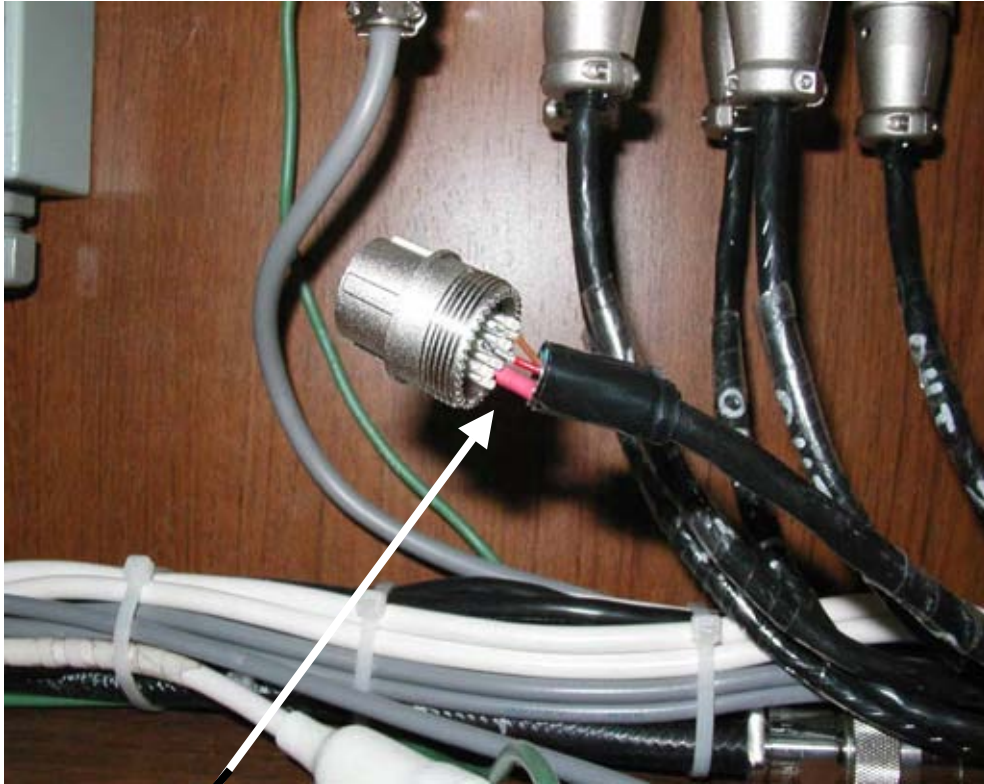
AP5.1.2 SRCN connector

Wires must be soldered to pins properly.
Never burn the insulator by the soldering iron.
It is recommended to use heat the shrink tubes (7 mm length).

SRCN connector

When grounding the grounding cable

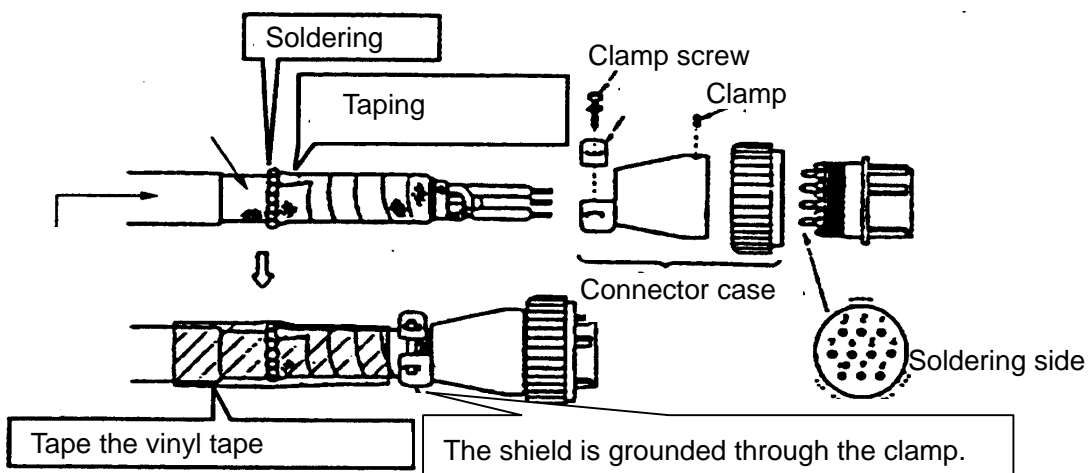

When not grounding the grounding cable

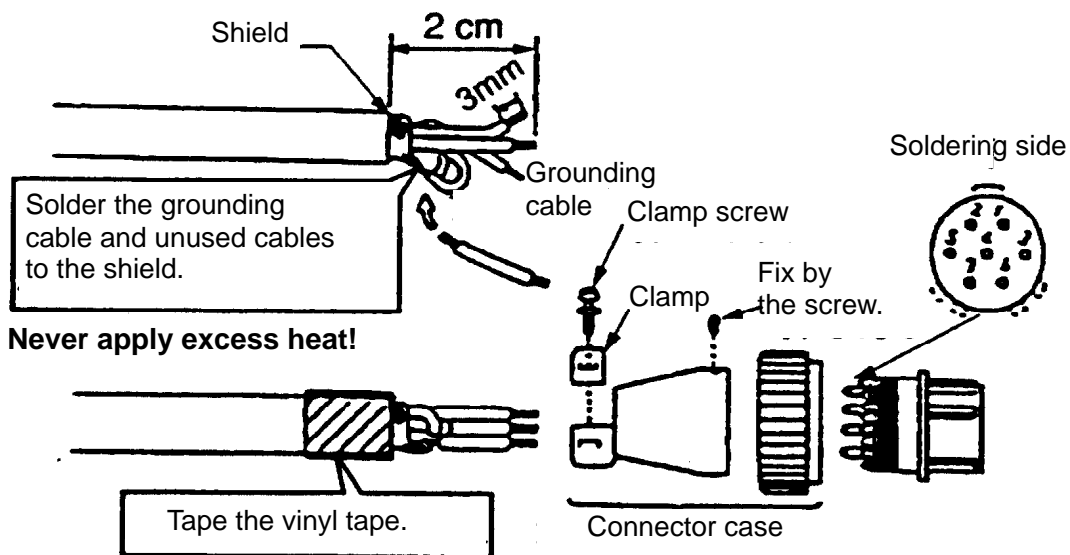

AP5.1.3 Fabrication of BNC connector

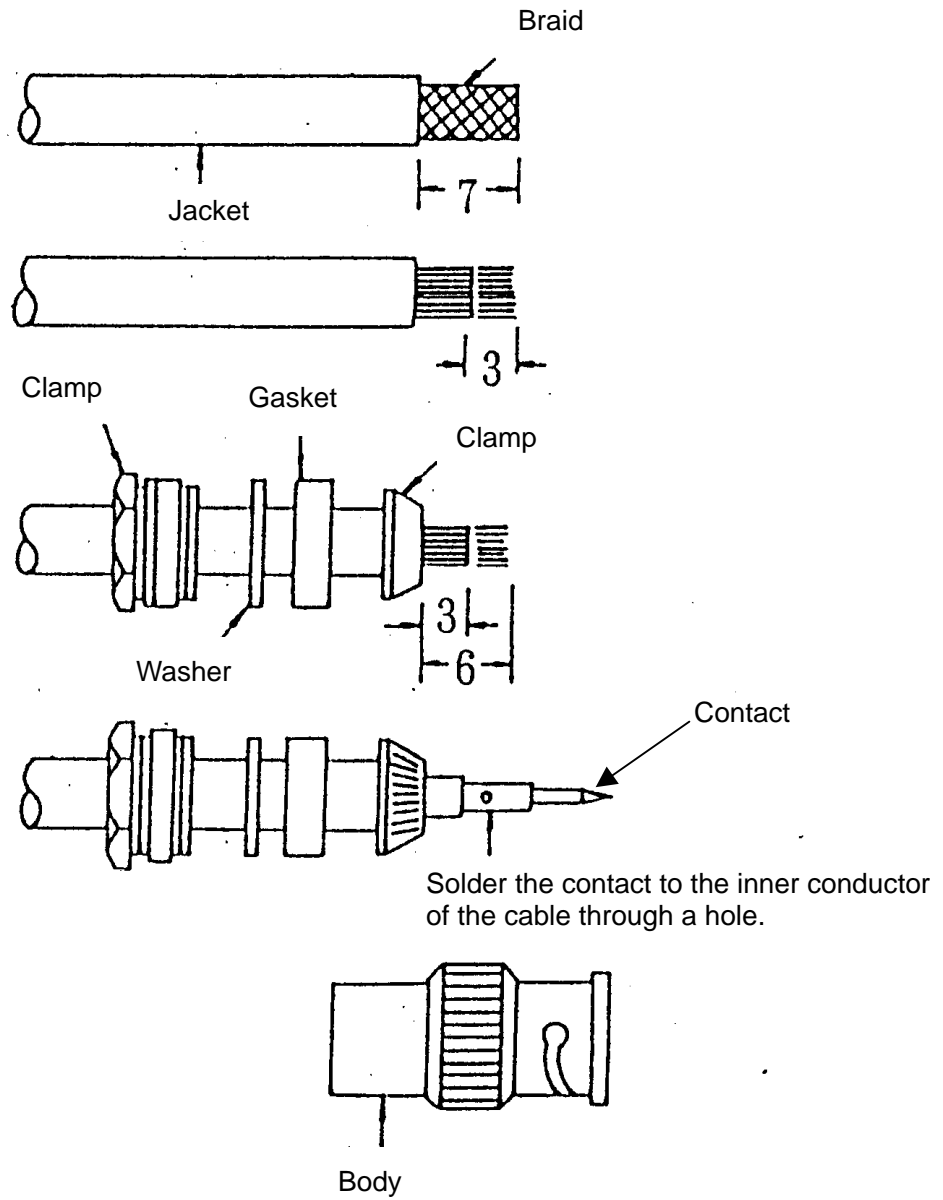

AP5.1.4 Fabrication of M-type coaxial connector

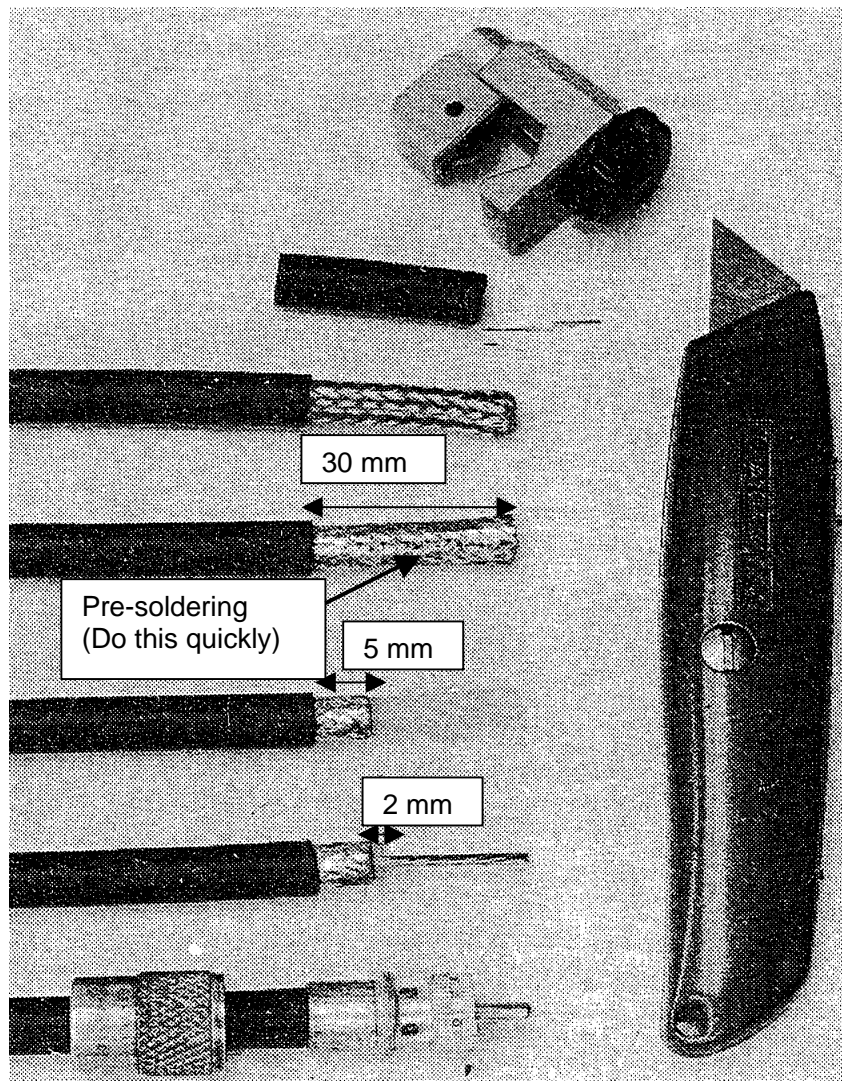
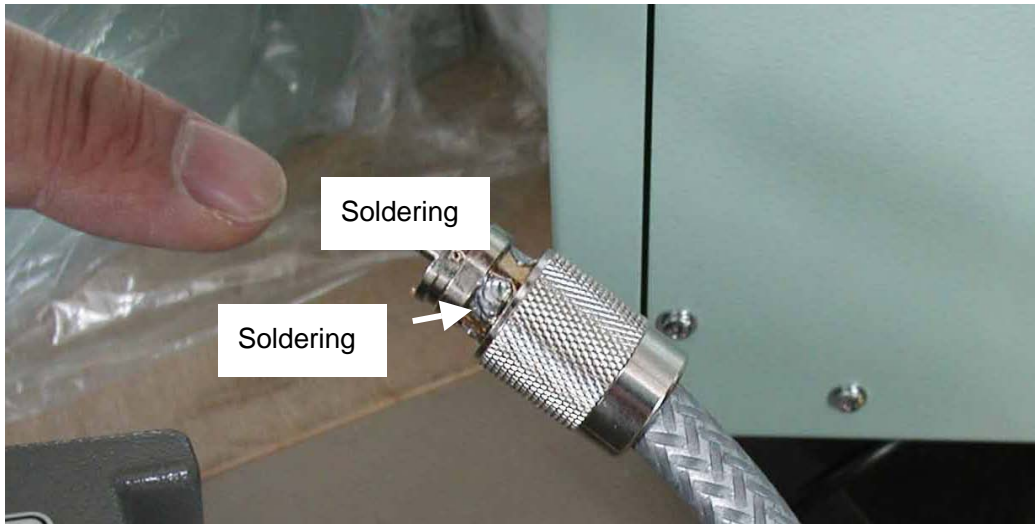

AP5.1.5 Fabrication of N-type coaxial connector (N-P-8DFB)

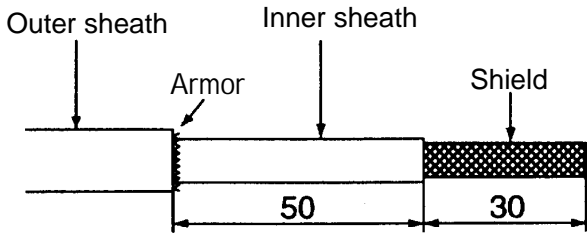

Cut a break to the aluminum tape every 90 degrees.

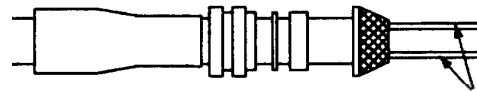

Heat shrinking tube

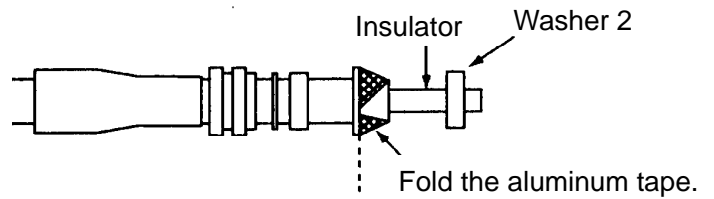
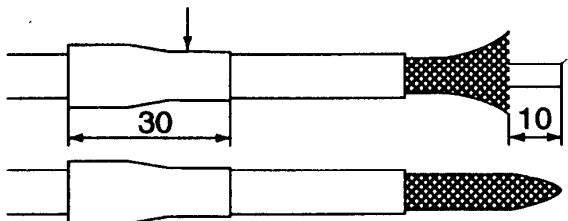

Cut the aluminum tape even.

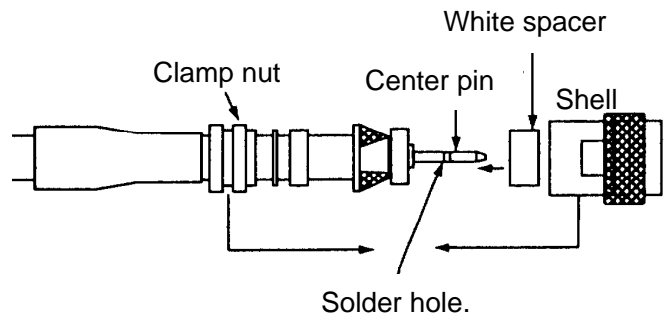
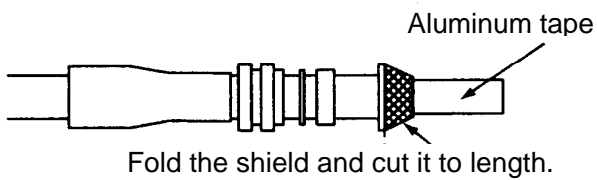
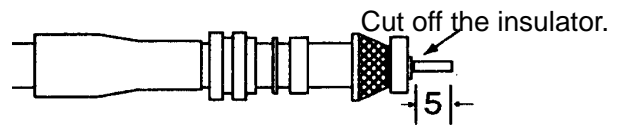
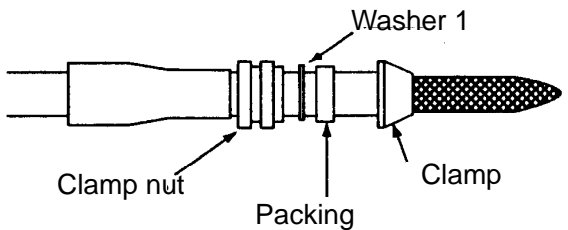

AP5.2 How to solder

AP5.2.1 Soldering

Use a suitable soldering iron

Use 30 to 80 W soldering iron for indoor, 100 W or more for outdoor. Using the soldering iron of lower wattage results in bad soldering.



The shape of the tip is important. This type of the tip is ideal for soldering wires.



Example: 15 to 150 W adjustable soldering iron

Procedure

1. Apply a thin layer of solder to the part to be soldered.
2. Heat both parts of the joint by soldering iron.
3. In a couple of seconds, the two parts to be jointed will reach the solder's melting temperature. And, apply the solder.
4. Remove the soldering iron from the point. And, do not move the point until the solder is completely hard.

Good and bad examples of the soldering



Good example



Bad example: Not enough temperature



Bad example:
Excess solder (causing
vibration problem)

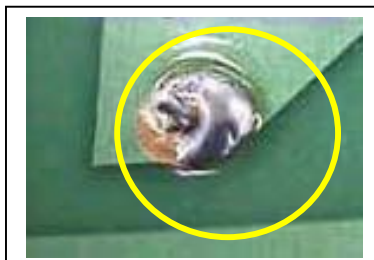

Bad example:
Little solder (Half finished
appearance)



Bad example:
Bridge to other contact

AP5.2.2 Soldering connector plug

Soldering for Multi-pin connector

1. Strip the jacket.



2. Twist conductors.



3. Apply a thin coating of the solder.



4. Cut the conductor to length.



5. Apply a thin layer of solder to the tap.



6. Put the heat shrinking tube over the sheath.



7. Place the tinned wire on the tap and heat them. When the solder starts melting, apply the end of the solder.



8. Use the right amount of solder. Do not move parts until the solder has cooled.



Bad example

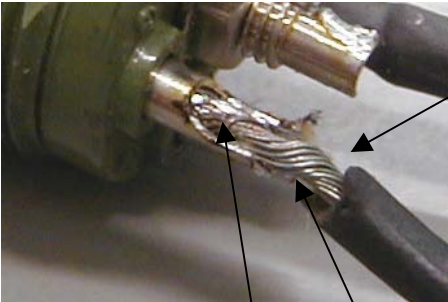

Conductors are not thoroughly covered by solder because of low temperature.

Jacket is removed too long.

Too little of solder

9. Place the heat shrinking tube in place.



10. Heat the tube by the soldering iron.



Soldering for M-P connector

1. M-P connector



2. Slide the coupler over the cable.



3. Strip the cable 300 to 400 mm. Do not nick the braid.



4. Apply a thin layer of solder.

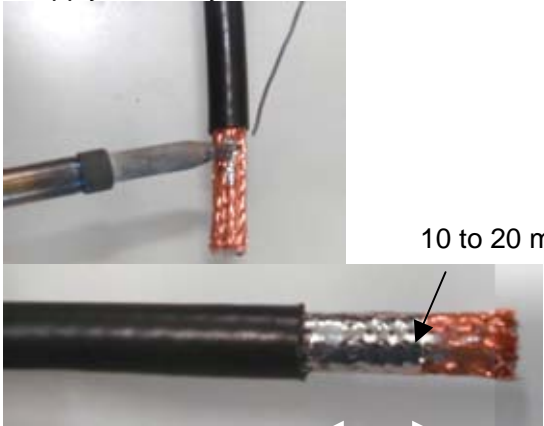

5. Tape the soldered area.



6. Mark 10 mm from the end.



7. Remove the shield from the mark.



8. Remove the insulator leaving it 2 mm from the shield end.

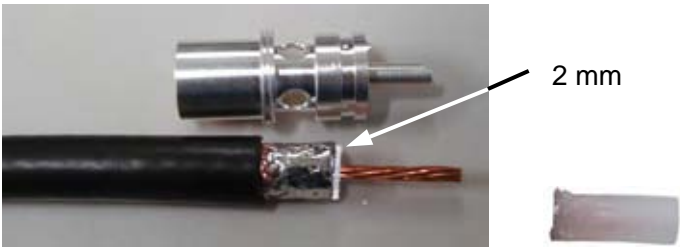

Never nick the center conductor.

10. Tin the end of the center conductor.



11. Insert the cable in the M-P connector as far as it will go.



12. Solder the connector and shield through holes.



13. Solder the center conductor.



Do not apply excess solder.

14. Trim the center connector.



15. Be sure that the solder covers holes entirely with a smooth shiny appearance.



Good appearance of soldering



Bad example;

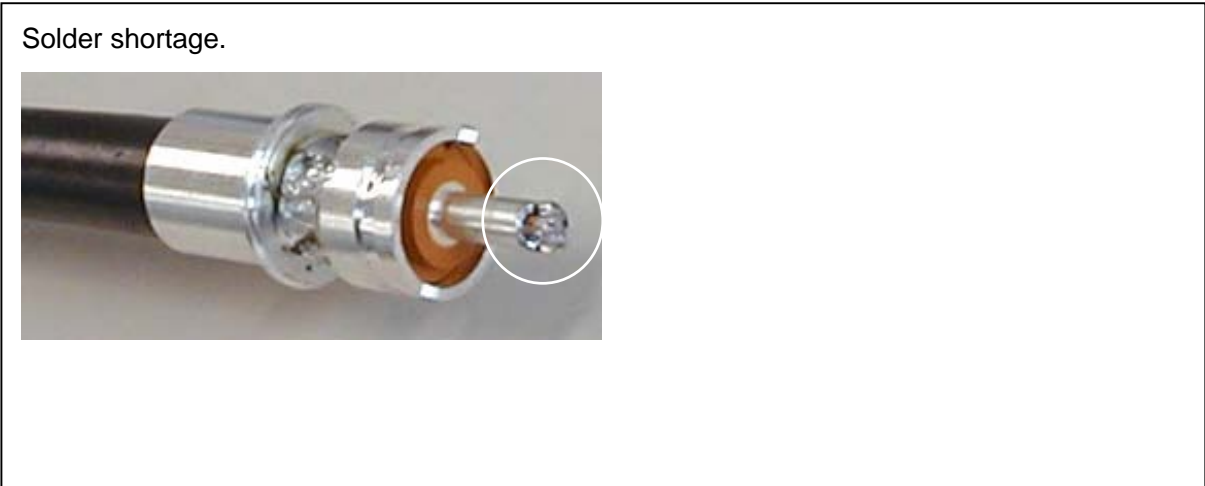
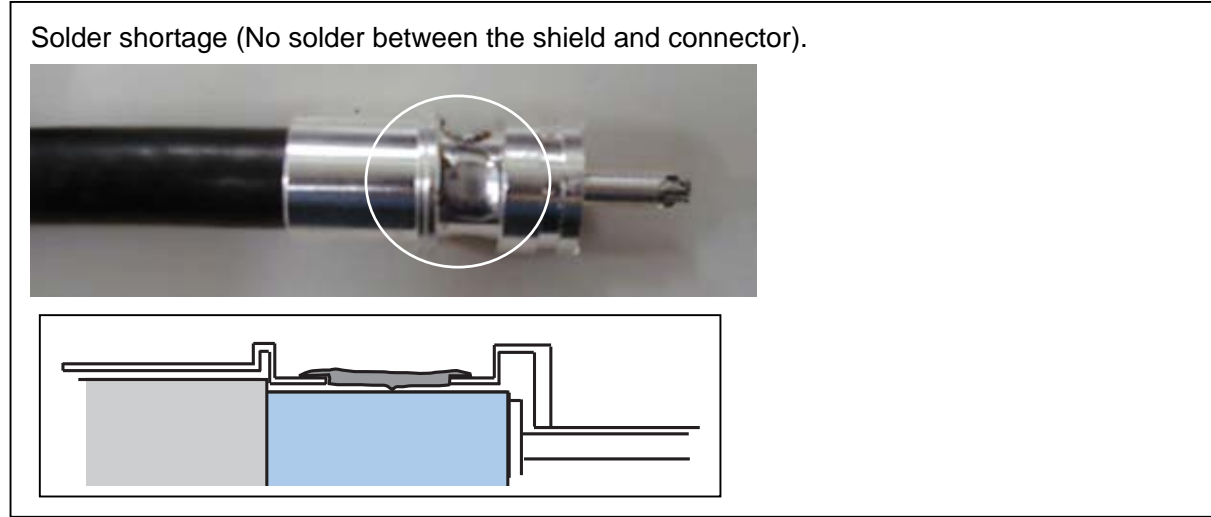
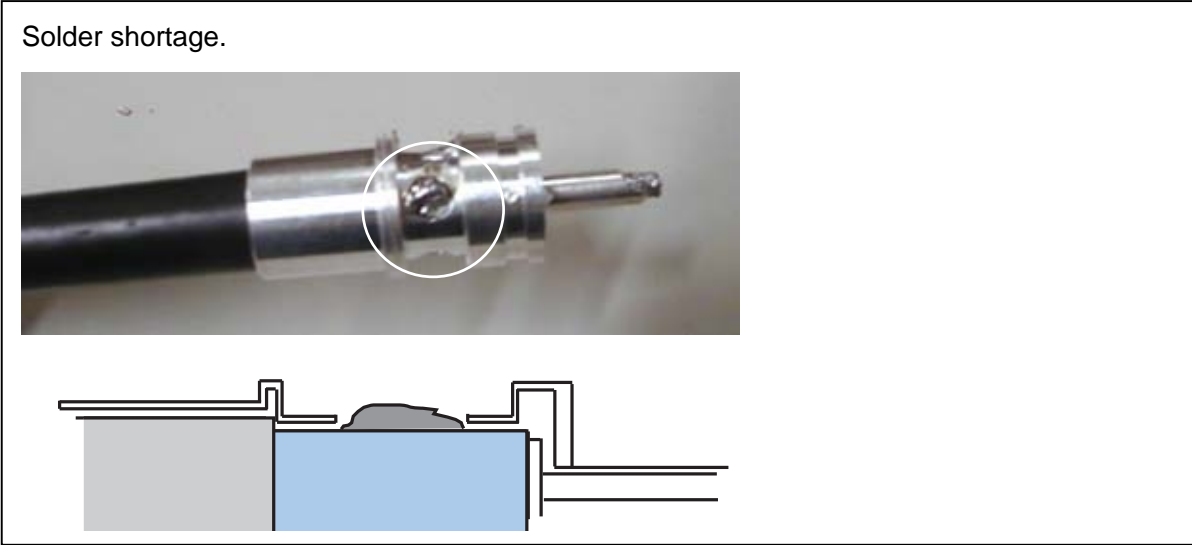

AP5.3 Waterproofing by taping



Vinyl tape



Self-bonding tape

For waterproofing, wrap the self-bonding tape three times. Then, wrap vinyl tape over the self-bonding tape.

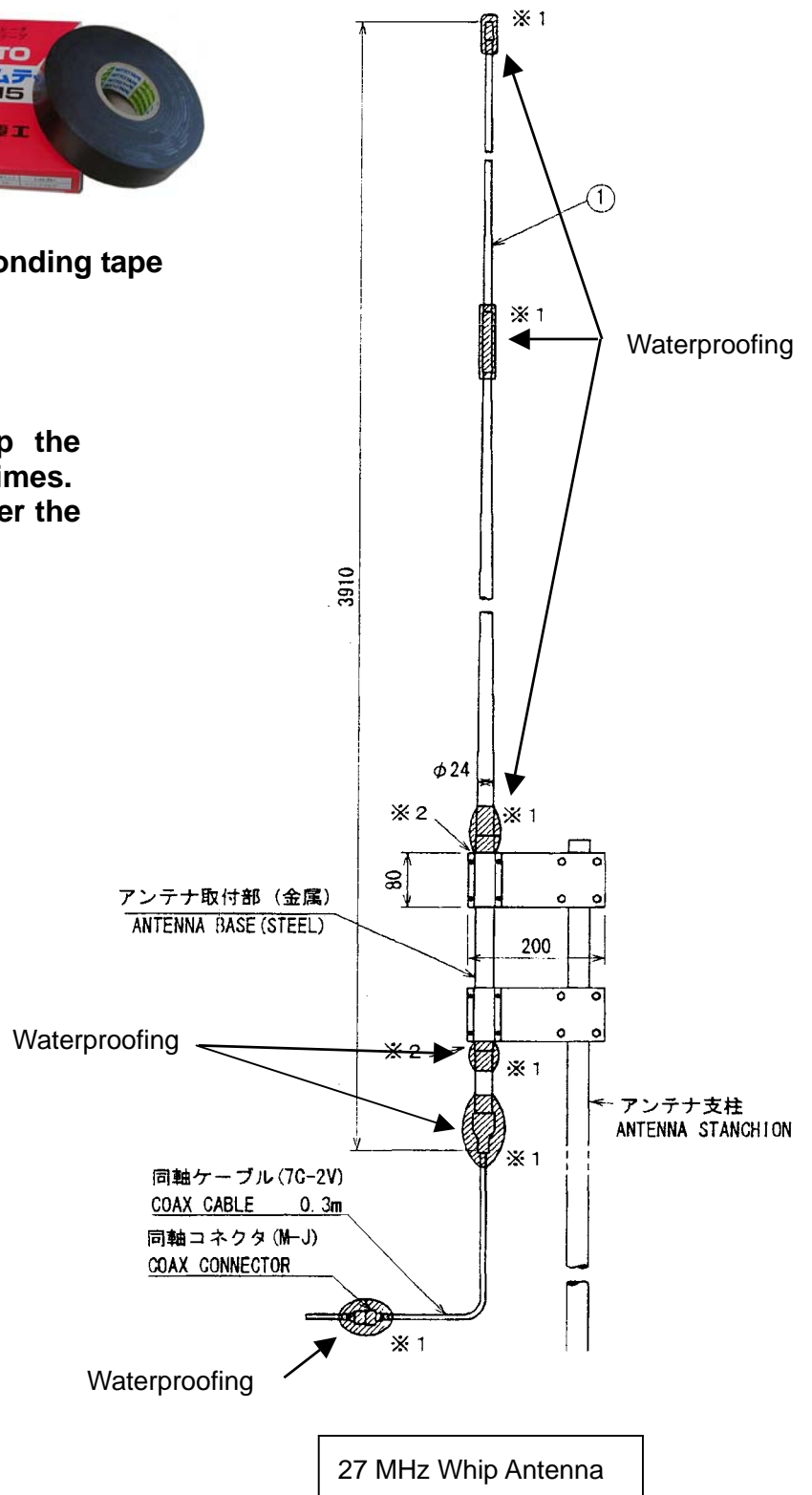

How to taping

