

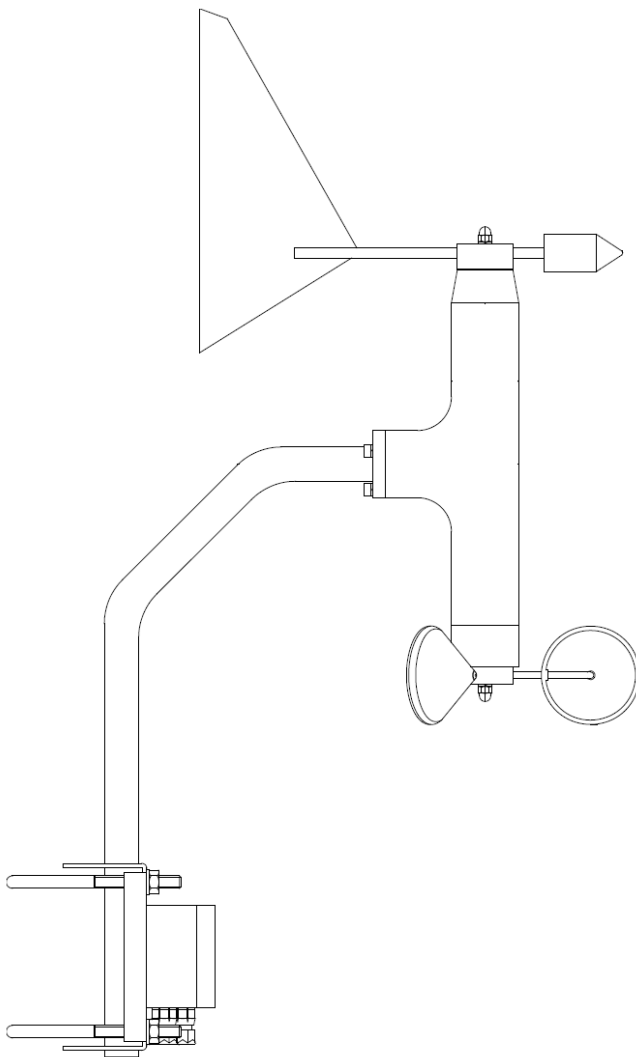

**OBSERVATOR**  
instruments

# OMC-160 Anemometer Meteorological Applications

**Installation & technical user manual**



**Version 2.04**  
TDC 28-11-2013

Version history

2.04 28-11-2013 Corrected part number of Wind vane (page 11)

**TABLE OF CONTENTS**

<b>1. GENERAL.....</b>	<b>5</b>
1.1 DATA SUMMARY .....	6
<b>2. INSTALLATION.....</b>	<b>7</b>
2.1 MECHANICAL .....	7
2.2 ELECTRICAL .....	7
<b>3. COMMISSIONING .....</b>	<b>8</b>
3.1 ALIGN PROCEDURE .....	8
<b>4. SENSOR BODY .....</b>	<b>9</b>
4.1 MAINTENANCE .....	10
4.2 SPARE PARTS .....	11
<b>5. THE OUTPUT OF THE OMC-160 .....</b>	<b>12</b>
5.1 OMC-160 FORMAT .....	12
5.2 NMEA .....	12
<b>6. INTERNAL WIRING .....</b>	<b>13</b>
<b>7. CONNECTIONS .....</b>	<b>14</b>
7.1 JUMPER FUNCTION CONNECTION 13 & 14.....	14
<b>8. DIMENSIONS .....</b>	<b>15</b>
<b>9. DECLARATION OF CONFORMITY .....</b>	<b>16</b>

*Page intentionally left blank*

## 1. General

The wind sensor combination OMC-160 consists of the wind speed sensor and wind direction sensor. The system is robust, lightweight, corrosion resistive and easy to install.

The wind sensor is a rotary-cup type unit made from stainless steel. The 3 cups are helicoid shaped, 80 mm in diameter, with an outer spin diameter of 130 mm. Rotation of the cup-unit generates 8 pulses/rotation in an optical encoder. The encoder is directly connected to the micro processor which converts the pulses to wind speed in M/S.

The wind direction sensor is a wind vane type unit, made from stainless steel. The wind vane drives a resolver, from which the reference coils are connected to the microprocessor. The micro processor translates the sine and cosine output from the resolver into a direction signal.

The microprocessor transmitter is completely encapsulated to withstand extreme environmental conditions. It converts both the optical pulses from the wind speed and the resolver position from the wind direction, into a combined digital signal (serial current loop, 300 bps, ASCII code). This signal can be transmitted over cable lengths up to 1200 meters, but it can also be transmitted via VHF or other data-communication systems. The transmitter unit requires a 8- 30 volts dc supply, which is usually supplied by the indicator coupled to the wind sensor (typically 15Vdc).

### De-icing heaters

As an option, the wind sensors may be equipped with de-icing heaters. These heaters are located in the top part of the sensors. By heating the bearing-housing, it prevents the rotating parts freezing to the housing in case of precipitation at low temperatures. The heaters (24 Volts ac or dc, 35 Watt) are controlled by a thermostat in the sensor housing.

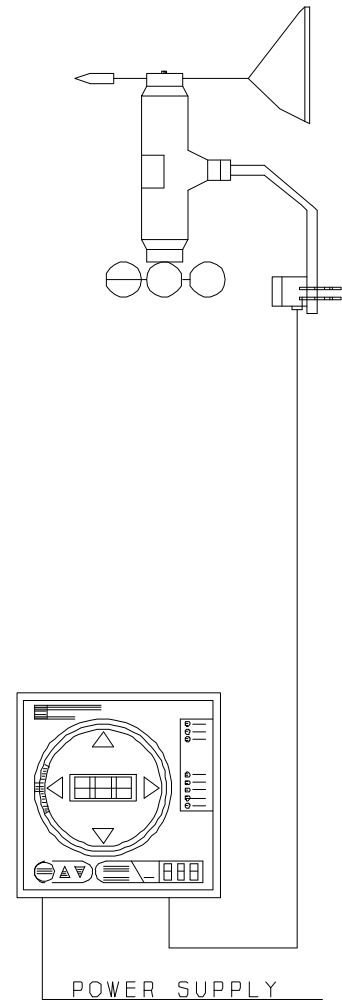

**1.1 Data summary**

Power supply:	8 TO 30 VDC 60 mA
Output:	Currentloop ASCII coded output 20 mA NMEA-0183 version 2.30
Weight:	6.5 kg
Dimensions:	865x248x465mm (DxWxH) see sketch chapter 8
Mounting pole:	max. 65 mm dia
Operating temperature:	-25 to 70°C
Moisture protection:	IP65
Humidity:	10 to 95%
Accuracy:	Wind speed: better than 2% FRO Wind direction: better than 3 degrees Speed range: 0,3...75 m/s
Class:	EMC EN 50081-1 class B, EN 50082-2 Conform RoHS directive 2002/95/EC en 2005/18/EC

## 2. Installation

### 2.1 Mechanical

The wind sensor OMC-160 is supplied with the mounting bracket and junction box. This can be mounted on a vertical pipe with external diameters between 35-60 mm using the U-bolt clamps supplied.

Before starting the installation, make sure that all components are complete, and that the mast is properly fixed to withstand rugged wind forces. The wind-sensors are usually shipped with the wind vane and cups disconnected from their appropriate units. On the common unit, the upper spindle is for the wind direction sensor, and the lower spindle for the wind speed sensor. To prevent damaging the wind vane and cups, properly mount the sensor/bracket combination on the mast before fitting the wind vane and cup-unit. (this may not always be possible)

Ensure that the sensors are mounted high enough to avoid any turbulence from obstacles. For guidance refer to the WMO publication 'Guide to Meteorological Instruments and Methods of Observation' (latest issue).

On completion of the above installation carry out the setting-up procedure as contained in the commissioning paragraph 3.1.

### 2.2 Electrical

The mounting bracket is provided with a junction box for connection of the field cabling. The combined wind sensor only requires a 4-core cable (2 twisted pairs, 0.75 mm<sup>2</sup>, common screen). In case that the sensors are equipped with de-icing heater, a 6-core cable is required with 2 extra cores for the heater.

Because the current drawn by the heater is  $\pm 2$  amp the cable from the sensor to the junction box should be as short as possible to prevent loss of power. For the cable from the junction box to the heater transformer the cable size depends on the length of that cable.

The field cable should be properly supported, and fastened to prevent exerting force on the terminals. The common screen of the cable must be grounded to earth on one end only, inside the junction box of the wind sensor.

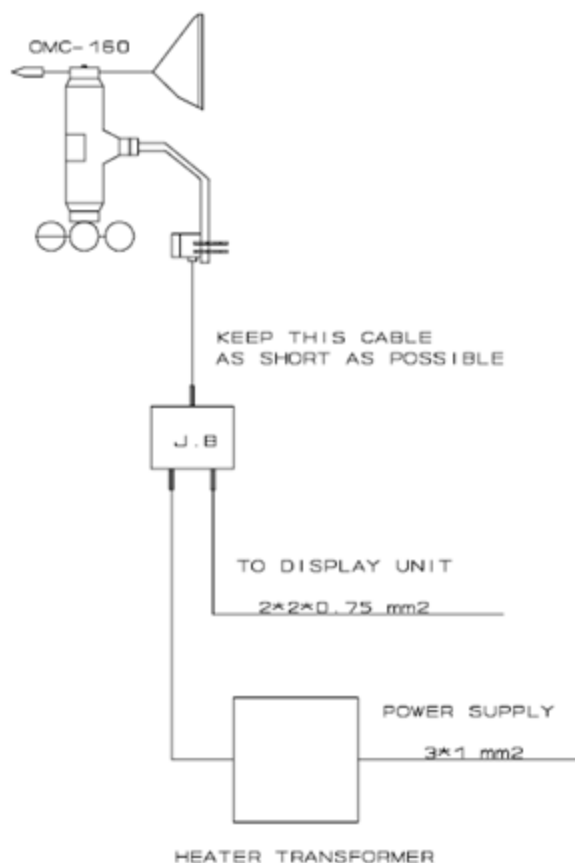

### 3. Commissioning

Before commissioning the wind sensor, check that the display is properly connected and the power is switched on. The display normally provides the 15 volts dc power supply to the wind sensor, which can be measured between terminals (1) and (2) at the rear of the display. The wind speed sensor needs no further commissioning, it will automatically transmit the measured speed.

#### 3.1 Align procedure

**Land-based:**

The wind direction sensor needs alignment. In land based systems the OMC-160 should be aligned to North. After alignment the OMC-160 wind sensor will report "absolute" wind direction. This way of alignment is also used on most fixed offshore rigs.

**Ship-based:**

On ship based systems the OMC-160 should be aligned to the bow of the vessel. After alignment the OMC-160 will report "relative" wind direction. This way of alignment is also used on small buoys and on some offshore objects as F(P)SO's.

For the purpose of alignment the sensor is provided with an LED located in the junction box mounted on the mounting bracket which will light-up when the sensor transmits a direction signal around zero degrees (between 350 and 010 degrees):

1. Open the cover of the junction box that is located on the mounting bracket to observe the LED.
2. When the color of the LED is green the sensor transmits a direction between 002 to 010 degrees.
3. When the color of the LED is red the sensor transmits a direction between the 350 and the 358.
4. When the color of the LED turns yellow the transmitted signal is "North" or 0 degrees, within a band width of 2 degrees.
5. For land based alignment locate North by using a hand held compass or similar.
6. Unscrew the locknut of the wind vane
7. Put a screwdriver in the groove of the vane-shaft and set the counterweight of the wind vane pointing to North or the ships bow, and keeping it in this position, slowly turn the shaft with the screwdriver until the LED lights up.
8. Fine adjust the shaft until the LED lights yellow (i.e. North or 0 degrees within 2 degrees)
9. Tighten the lock-nut of the wind vane, taking care that the vane does not move on the shaft.
10. Check the "North" transmitting signal with LED after tightening the vane locknut.
11. Close the junction box cover.

**Remark:**

*Depending on local circumstances, it may be more practical to align the wind vane with the sensor mounting bracket and adjust the wind vane shaft until the LED light. The mounting bracket can then be aligned to the north by rotating the complete mast, thus aligning the wind vane to the North.*



#### 4. Sensor body

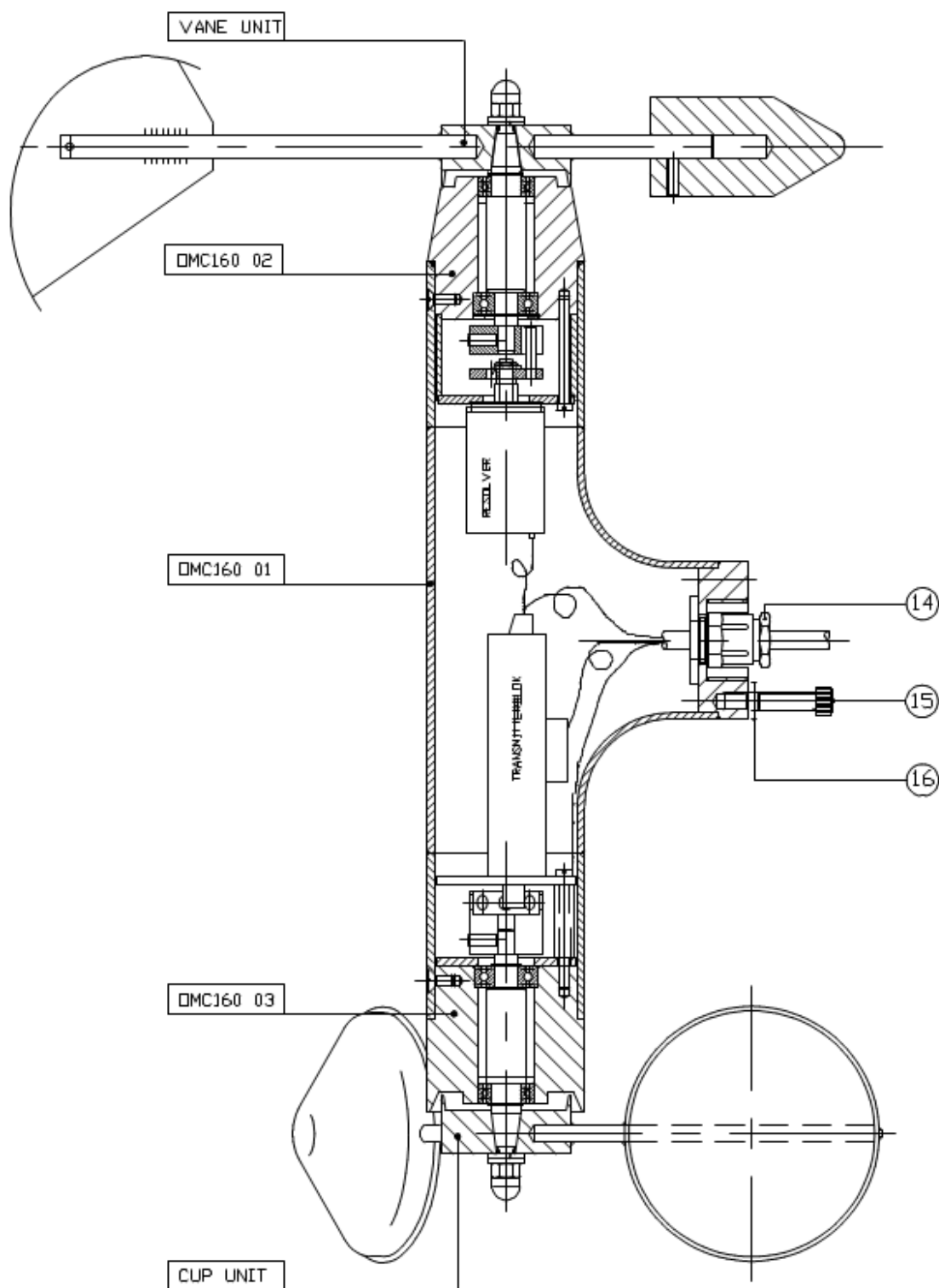

#### 4.1 Maintenance

The OMC-series wind sensors are designed for low maintenance and all components are conservatively rated. The only components that are likely to require replacement due to normal wear are the precision ball bearings. Replacement of these components should only be attempted by a qualified technician. It should be carried out in a workshop free from dirt and impurities.

Refer to assembly drawings of wind speed and, wind direction sensor for part names and locations. First remove the cup-unit or vane-unit from the body by unscrewing the locknut and lifting the unit. To gain access to the bearings remove the bearing housing by unscrewing the 3 screws on the side of the body. When lifting the bearing housing, the attached transmitter block in the speed sensor, or the resolver in the direction sensor will also be pulled out with the attached wiring. Before disconnecting this wiring mark the original connections.

In the wind speed sensor the transmitter block must be removed after which the columns can be screwed off to free the bearing lock plate. The bearings can now be taken out complete with the shaft. In the wind direction sensor this is done in a similar way after removing the resolver.

When the bearings are renewed, care should be taken not to apply excessive force on the new bearings.

The bearing housings of wind speed and wind direction units are not identical on the OMC-160.

When re-installing the complete bearing housing with the transmitter block or resolver, care should be taken that the internal wiring is properly connected, and not touching any moving part.

The cable-gland in the bottom part of the body should be tightened to support the field cable.

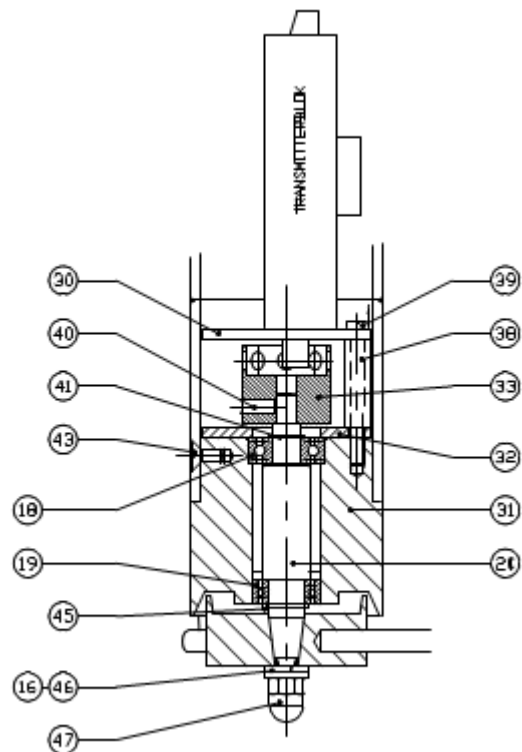
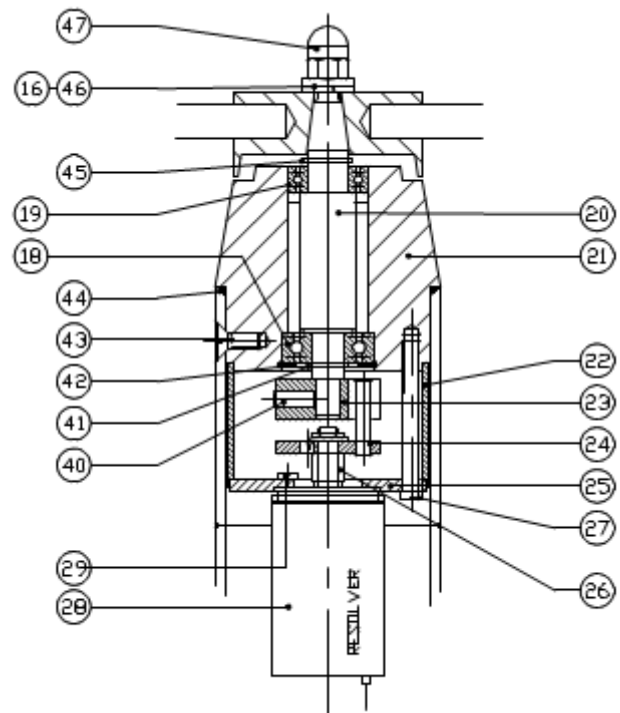

Parts with positioning numbers as used in the drawings on the previous pages.

Pos	Nr.	Description	Pos	Nr.	Description
18	2	Ball bearing	38	3	Distance column
19	2	Ball bearing	39	6	Hexagonal screw
20	2	Axis	40	2	Lockingscrew
21	1	Bearing wind direction	41	2	Circlip washer
22	1	Center bus	42	1	Circlip washer
23	1	Carrier fork	43	6	Countersunk head screw
24	1	Carrier pin plate	44	1	O-ring
25	1	Mounting plate resolver	45	2	Circlip washer
26	1	Distance tube resolver	46	2	Spring washer
27	3	Bolt	47	2	Cap nut
28	1	Resolver			
29	2	Screw	14	1	Cable gland
30	1	Transmitter block	15	1	
31	1	Bearinghouse wind speed	16		
32	1	Locking plate			
33	1	Pulse code cap			

#### 4.2 Spare parts

Part	: Part No.
Cup assembly	: OMC-9166
Fin assembly	: OMC-9165
Transmitter block	: OMC-9161
Ball bearing set	: OMC-9169

Retaining ring Diameter. 10 x 1 mm and 8 x 1 mm included in bearing set.



## 6. Internal wiring

Should for some reason the sensor not be electrically connected to the mounting bracket junction box, access must be gained to the interior of the sensor to enable connection of the field cabling. Remove the bearing-assembly from the sensor body by unscrewing the three screws on the side of the body, and lift the bearing-assembly. In the wind speed sensor the transmitter block is fitted to the bearing housing, and in the wind direction sensor the resolver is fitted to the bearing housing. From the wind direction resolver six signal cores are connected to the transmitter block in the wind speed sensor. The combined output signal is available on 14 screw terminals on the transmitter block. Field cabling can be connected either directly to the transmitter block terminals inside the speed sensor, or via a junction box on the mounting bracket. (see internal wiring diagram)

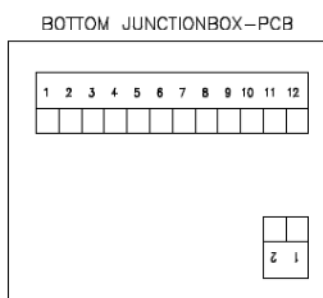

When changing this new electronics block into an older sensor, be sure the links is placed between X3.1 & X3.2

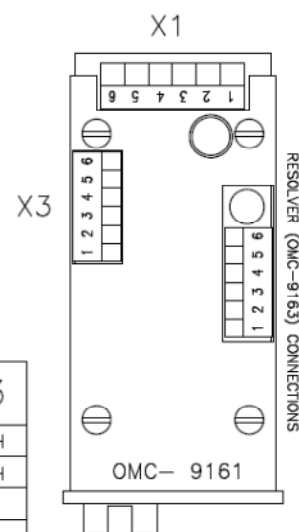

JUNCTIONBOX BOTTOM JUNCTIONBOX-PCB			OMC-9161
1	white	0	X1 - 1
2	brown	+12 Vdc	X1 - 2
3	green	-TTY	X1 - 3
4	yellow	+TTY	X1 - 4
5	grey	0	X3 - 1
6	pink	RTS / Y	X3 - 5
7	blue	TXD / Z	X3 - 4
8	red	RXD / A	X3 - 6
9	black	CTS / B	X3 - 3
10	purple	SEL	X3 - 2
11	grey/pink	LED 1	X1 - 5
12	red/blue	LED 2	X1 - 6
1	white/green	HEATING	HEATING
2	brown/green	HEATING	HEATING

OMC-9163
1 = BK/WH
2 = RD/WH
3 = RD
4 = BK
5 = YE
6 = BL

## 7. Connections

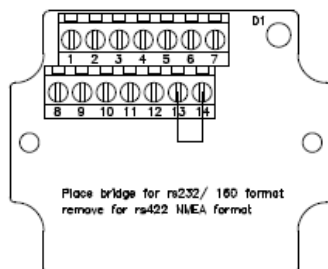

JUNCTIONBOX		
1	0	Powersupply
2	+12 Vdc	Powersupply
3	-TTY	rs 232/ 160 format
4	+TTY	rs 232/ 160 format
5	Heating	
6	Heating	
7	EARTH	
8	GND	
9	RTS / Y	rs422/ NMEA
10	TX / Z	rs422/ NMEA
11	Rx / A	
12	CTS / B	
13	Bridge to 14	
14	Bridge to 13	

### 7.1 Jumper function connection 13 & 14

In the junction box of the OMC-160 a jumper can be found on terminal 13 & 14. It is possible to set different output types with this jumper. The available settings are:

**Jumper in place:**

- Baud rate 300 baud
- OMC-160 format on terminal 3 & 4 Currentloop
- OMC-160 format on terminal 1 & 9 RS232
- 

**Jumper removed:**

- Baud rate 4800 baud
- NMEA format on terminal 3 & 4 Currentloop
- NMEA format on terminal 9 & 10 RS422

## 8. Dimensions

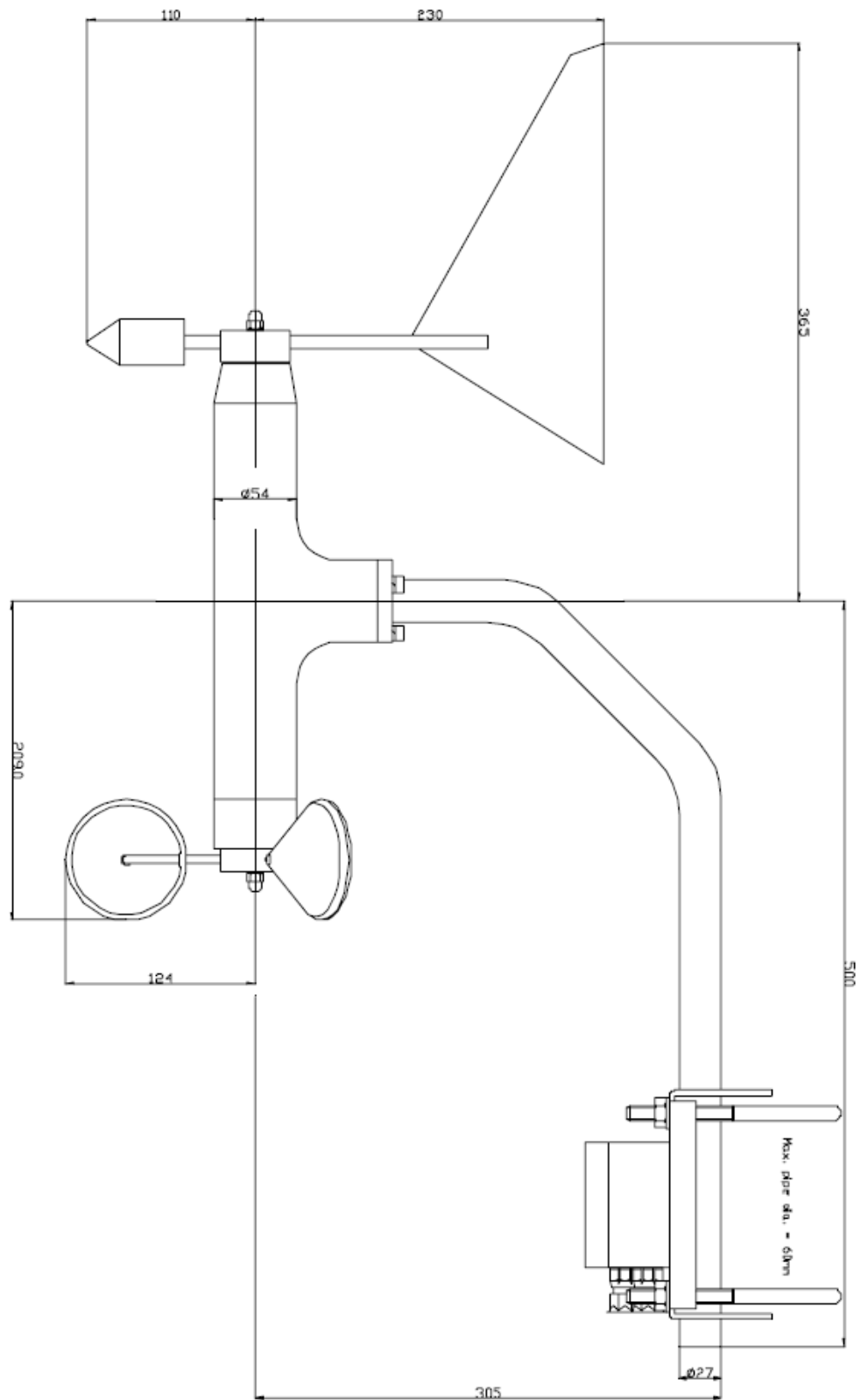

## 9. Declaration of Conformity



**OBSERVATOR** instruments bv

Rietdekkerstraat 6  
2984 BM Ridderkerk  
The Netherlands

Postbus 60  
2980 AB Ridderkerk  
The Netherlands

tel.: +31 (0) 180 463411  
fax.: +31 (0) 180 463510  
email: info@observator.com

### *MANUFACTURERS DECLARATION OF CONFORMITY*

**Product**

OBSERMET OMC-160 and OMC-160-II wind sensor  
with OMC-167 mounting bracket  
including all options

**Manufacturer**

Observator instruments b.v.  
Rietdekkerstraat 6  
2984 BM Ridderkerk  
The Netherlands

**Means of conformity:**

The product is in conformity with the directive 89/336/EEC based on test results  
using the generic standards EN 50081-1 and EN-50082-1 in accordance with Article  
10 (1) of the directive

**Signature of Manufacturer**

We declare that the product described conforms with the requirements of the EMC  
directive 89/336/EEC.

Ridderkerk  
16nd January 2006



Drs. R. de Vries  
General Manager

File number: legconf0160