



METEOROLOGICAL INSTRUMENTS

INSTRUCTIONS

METEOROLOGICAL TRANSLATOR MODEL 26800

MODEL 26800
METEOROLOGICAL
TRANSLATOR



1.0 INTRODUCTION

The Young 26800 Meteorological Translator is a programmable digital display and data recorder for use with a wide range of meteorological sensors.

FEATURES:

- All-in-one design
- Illuminated display with 8 screens
- Brightness and contrast control
- Large and small fonts, up to 240 characters per screen
- Simple, intuitive, easy-to-navigate menus
- 16 single-ended or 7 differential voltage inputs in any combination
- 4 pulse or frequency inputs in any combination
- 4 analog outputs, voltage or current in any combination
- 4 solid-state switch outputs
- Independent RS-232 and RS-485 serial communication ports
- Capacity for 512 user program instructions
- Capacity for over 2 million non-volatile floating point data records
- Simple setup via front panel or easy-to-use PC program

Complete specifications are in APPENDIX A

1.1 PRECAUTIONS

- Indoor use only unless operated in a suitable enclosure.
- Always connect ground terminal to suitable earth ground.
- Switch power OFF before connecting sensor wires.
- Disconnect power before servicing unit.
- Operating range is 0°C to 50°C, 0 to 95% RH
- Some sensors may require connection to a proper earth ground to prevent possible sensor damage or malfunction due to static discharge. Follow instructions provided with sensor.

1.2 OPERATING CONTROLS

FRONT PANEL

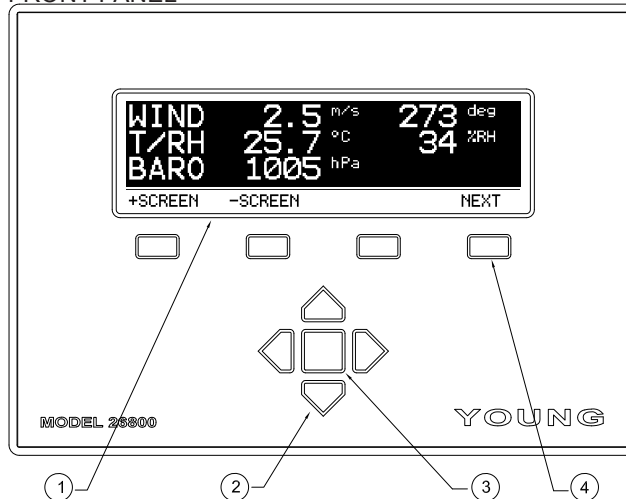

- | | |
|-------------------|--|
| 1. Screen display | Large font, 3 rows x 20 columns
Small font, 6 rows x 40 columns |
| 2. ARROW keys | Navigate screen, change values |
| 3. ENTER key | Select highlighted item |
| 4. SOFT keys | Select function indicated on screen |

BACK PANEL

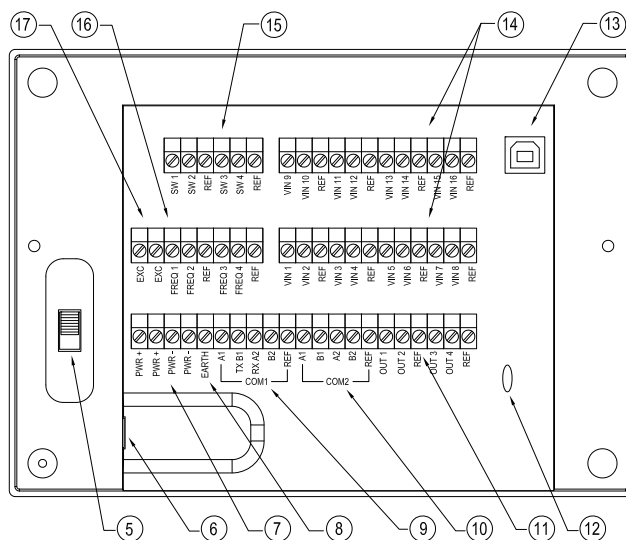

- | | |
|----------------------|--------------------------------|
| 5. ON/OFF switch | 11. Voltage/Current outputs |
| 6. Power supply jack | 12. Cable tie-down point |
| 7. Auxiliary power | 13. USB port |
| 8. Earth ground | 14. Voltage inputs |
| 9. COM1 terminals | 15. Solid-state switch outputs |
| 10. COM2 terminals | 16. Pulse/Frequency inputs |
| | 17. Excitation Voltage (5V) |

1.3 GETTING STARTED

Sensors and power supply adapter should be properly connected before operation (refer to APPENDIX B). Set power switch to ON position. After 3 seconds, display appears:



Typical display with program installed

The system is now operating. In OPERATE MODE, the 26800 executes USER PROGRAM instructions which may collect sensor data, store records, process data, display results, produce outputs, or communicate via serial ports. When the 26800 is powered up, it automatically enters OPERATE MODE.

Typically, measured data will appear on the display. If multiple sensors are connected, data may appear on more than one screen.

There are 8 display screens available. Use +SCREEN and -SCREEN soft-keys to select screen view. SCREEN SCROLL settings or USER PROGRAM instructions may limit the viewable screens to less than 8.

Press the NEXT soft-key to cycle through OPERATE MODE options:

+SCREEN/-SCREEN	Selects screen.
+BRIGHT/-BRIGHT	Sets display brightness.
+CONTRAST/-CONTRAST	Sets display contrast.
EXIT	Exits OPERATE MODE to the MAIN MENU

2.0 MAIN MENU

Reach the MAIN MENU from OPERATE MODE by pressing the NEXT soft-key until the EXIT option appears. Press the EXIT soft-key. MAIN MENU appears.

Use ARROW keys to navigate the MAIN MENU. Use the ENTER key to select menu item.

All parameters in the MAIN MENU may be also be set or examined using the RMYComm PC program included with the 26800. When making extensive changes, we recommend using RMYComm rather than the 26800 keypad.

You cannot harm the unit by examining or changing parameters although altered settings will affect how the unit operates.

OPERATE returns to OPERATE MODE and begins executing the user program.

DATE/TIME shows the current date and time to the nearest minute. Time is kept in 24-hour format. The internal clock runs from a lithium battery when power is off. Depending on use, the battery will last up to 10 years. The internal clock automatically accounts for leap years. Select EDIT or EXIT.

USER PROGRAM shows program instructions that execute in OPERATE MODE. Use ARROW keys to navigate instructions. The instruction number appears in the upper-left corner. For further details about program instructions, see section 4.0 PROGRAMMING.

SCREEN TEXT sets fixed text labels on each of the 8 display screens. Use ARROW keys to navigate. Select screen number and press ENTER key.

Select EDIT to change text or EXIT to leave.

When editing:
RIGHT and LEFT ARROW select character.
UP and DOWN ARROW change character value
LARGE and SMALL select font size.
LINE selects vertical row.

Select EXIT when finished.

SERIAL COMM lists serial port type and baud rate settings. COM1 may be set to operate as an RS-232 or RS-485 port. COM2 is always RS-485. Select EDIT to change. Use UP and DOWN ARROW keys to change value. Select EXIT to leave.

UTILITY shows the UTILITY MENU where additional parameters may be examined or changed.

3.0 UTILITY MENU

The UTILITY MENU is a subset of the MAIN MENU. From the MAIN MENU, use ARROW keys to navigate to the UTILITY menu item. Press the ENTER key.

Use ARROW keys to navigate the UTILITY MENU. The ENTER key selects the indicated menu item.

RECORD FIELDS defines the number of fields per record when recording data. Generally, one field is assigned for each value that will be stored in a record. For example, if Date, Time, Wind Speed, and Wind Direction are recorded (4 separate values), REC FIELDS would typically be set to 4. When records are retrieved, these 4 values will be grouped together on each line.

RECORD ERASE deletes all recorded data.

PROGRAM CHECKSUM calculates a unique checksum signature for the User Program. The signature value may be used to validate program integrity.

PROGRAM INTERVAL determines how often, in seconds, the program is executed. The program interval must be long enough to execute all instructions. If the PGM INTERVAL is not long enough for all instructions to execute and the PGM ERR HANDLE is set to STOP, an error message will appear. To eliminate this error, increase the number of seconds in the PGM INTERVAL or decrease the number of instructions. Note that different instructions require different amounts of time to execute. Some VOLTAGE INPUT measurement configurations require the longest execution time. A sample interval of 00 seconds will run the program at maximum speed with no delay between iterations.

IMPORTANT NOTE ABOUT PROGRAM INTERVAL:
User Program Instructions IF TIME INTERVAL and FLAG TIME INTERVAL require a PROGRAM INTERVAL setting of 00 or 01 seconds so the time may be examined on every iteration of the USER PROGRAM.

PGM ERR HANDLE determines whether to STOP or SKIP errors during OPERATE MODE. When set to STOP, an error message will appear with an option to edit the offending instruction. A common technique is to set this parameter to STOP during program development and SKIP during normal operation.

Also see User Program Instruction LOC1=FUNCTION(LOC2) for detecting and responding to errors in the user program.

PROGRAM ERASE deletes all USER PROGRAM instructions.

KEYPAD LOCKOUT defines front panel key behavior during OPERATE MODE. When set to LOCKED, keys do not respond. When set to UNLOCKED keys respond normally.

Once LOCKED the keys may be reset to UNLOCKED in one of two ways. Method one: remove and re-apply power while pressing the two outer-most soft-keys. The 26800 will go to the

MAIN MENU. Navigate to the KEYPAD LOCK parameter and set it to UNLOCKED. Method two: Use RMYComm to reset the KEYPAD LOCKOUT parameter.

SCREEN SCROLL sets parameters that automatically scroll the display through one of 8 screens. END SCREEN also sets the last screen to show in manual scroll mode.

AUTO SCROLL: ON or OFF
END SCREEN: Last screen to show, 1-8
PAUSE (SECONDS): Duration of pause, 01-99

4.0 PROGRAMMING

In OPERATE MODE, the 26800 executes a list of USER PROGRAM instructions to make measurements, display data, manipulate data, record data, test for conditions, and produce output. The instructions may be combined in any way for a broad range of applications.

The user program environment has three memory areas with various capacities.

Program Instruction: 512 instructions
Temporary Storage: 256 data values
Recorded Data: 2,162,688 data values

USER PROGRAM instructions may be entered, edited, or deleted using the front panel keys or remotely via serial communication and RMYComm.

IMPORTANT NOTE ABOUT PROGRAM DEVELOPMENT:

When developing your own programs, set PGM ERR HANDLE to STOP. This allows the 26800 to stop and identify sources of error in the USER PROGRAM when in OPERATE MODE. In most cases, specific offending instructions and parameters will be identified. After your program has been developed and demonstrated to operate without error, you may set PGM ERR HANDLE to SKIP which will omit execution of instructions in which errors arise and continue execution of other instructions.

VIEWING PROGRAM INSTRUCTIONS

From the MAIN MENU, navigate to USER PGM and press the ENTER key. The first program instruction will appear.

Example:

```
i001 INPUT VOLTAGE
chan= 16          rate= 300Hz
type= SE          dloc= 001
mult= 1.00000
offs= 0.00000
```

The i001 designation is the sequential instruction number which ranges from 001 to 512. The instruction description appears next. Instruction parameters are below the instruction description. In this example, there are six parameters.

Use the LEFT and RIGHT ARROW keys to navigate the USER PROGRAM. The last instruction is always PGM END. Navigation will wrap from end to beginning and vice versa. Press the EXIT soft-key to return to the MAIN MENU.

EDITING PROGRAM INSTRUCTIONS

Only parameters for an instruction may be edited. To replace an entire instruction, DELETE it then INSERT another instruction in its place.

To edit a parameter, press the EDIT soft-key. The selected character or field will be highlighted.

UP/DOWN navigation keys change value.
RIGHT/LEFT navigates characters in the field.
NEXT soft-key advances to the next parameter.

After progressing through each parameter, the 26800 will exit edit mode and return to view mode.

INSERTING PROGRAM INSTRUCTIONS

Press the INSERT soft-key to insert a new instruction ahead of the current instruction. Select the instruction to be inserted from the highlighted list:

UP/DOWN ARROW scrolls through the instruction list.
SELECT inserts the currently highlighted instruction.
CANCEL cancels insertion and returns to view mode

Insertion forces instruction renumbering.

DELETING PROGRAM INSTRUCTIONS

Press the DELETE soft-key to delete the current instruction. Any instruction may be deleted except PGM END. Deletion forces instruction renumbering.

4.1 PROGRAM CONCEPTS

The 26800 executes USER PROGRAM instructions to measure, process data, display, record, produce calibrated output, or communicate with other devices.

A USER PROGRAM is assembled from a list of available instructions. Most instructions use TEMPORARY STORAGE LOCATIONS which allow instructions to share data values. There are 256 locations available. Any location may be identified as a destination or source (DLOC or SLOC) depending on context. Values in these locations exist only while the program operates. Recorded values are stored in a separate area.

A simple USER PROGRAM example follows:

```
i001 INPUT VOLTAGE
chan= 16          rate= 300Hz
type= SE          dloc= 001
mult= 1.00000
offs= 0.00000
```

```
i002 DISPLAY VALUE
sloc= 001         col= 30
scrn= 1           width= 7
font= SMALL      decpt= 2
row= 5
```

```
i003 PGM END
```

Labels i001, i002, and i003 indicate the sequential instruction number. As instructions are inserted or deleted, each one is renumbered in sequence. Use these numbers to navigate the USER PROGRAM.

The first instruction, INPUT VOLTAGE, makes a single-ended (SE) voltage measurement on input channel 16. It measures at a sample-rate of 300Hz, multiplies the measurement by 1.00000, applies a 0.00000 offset, and stores the result in DLOC 001.

The second instruction, DISPLAY VALUE, displays the value in SLOC 001 on screen 1, row 5, column 30, using a small font format seven characters wide with 2 digits after the decimal point.

PGM END designates program end.

Please see the APPENDIX C for a more extensive example.

4.2 PROGRAM INSTRUCTIONS

Instruction names are listed below. Each instruction is followed by a detailed description of its function and parameter settings.

ALARM tests the value in a specified SLOC and activates one of the SOLID STATE SWITCH channels if the value meets conditions defined in the parameters.

SPAN determines how to compare the value in SLOC to the range defined by SETPOINT 1 and 2. INCL (inclusive) compares SLOC to values inside the range. EXCL (exclusive) compares SLOC to values outside the range. DELAY sets the duration the compare condition must be true in order to change the SW state. Use this to prevent switch chatter when the input value hovers near SETPOINT thresholds.

sloc= Source location (001-256)
set1= Setpoint 1
set2= Setpoint 2
delay= Number of seconds (00-99)
span= Span logic (INCL or EXCL)
sw= SOLID STATE SWITCH channel (1-4)

AVERAGE calculates the average of samples retrieved from SLOC. Values are evaluated on each iteration of the instruction. #SAMP is used on MOVING type averages only. BLOCK type calculates the result when FLAG 1 is set. The result is stored in DLOC.

BLOCK type adds new values to an internal sum with each instruction iteration. When FLAG 1 is set, the average is calculated and stored in DLOC. Typically, FLAG 1 is set using the FLAG TIME INTERVAL instruction.

MOVING type keeps a list of every sample. After #SAMP samples have been collected, the first average is calculated. After that, a new average is calculated for each new sample acquired. The amount of internal memory used is proportional to #SAMP. An error message will appear if memory limits are reached.

ANGLE type temporarily converts unit vector angles to Cartesian form which are used for the actual calculation. Cartesian averages are then converted back to angles for the final result.

sloc= Source location (001-256)
dloc= Destination location (001-256)
type= BLOCK, BLOCK ANGLE, MOVING, MOVING ANGLE
#samp= Number of samples, MOVING type only (0001-7000)

BEEP produces from 1 to 9 beep sounds. It can be used to signal an event.

num= Number of beeps to sound (1-9)

CHANGE TO SCREEN instructs the unit to change to a screen number based on the value in SLOC. The value in SLOC must be in the range of 1 to 8.

sloc= Source location (001-256)

DELAY creates a millisecond delay in program execution to the nearest multiple of 5 milliseconds.

msec= Millisecond delay (5-9995)

DISPLAY FLAGS shows the condition of all 16 user flags in either HEX or BINary format. The flags are numbered 1 to 16 from right to left. Digit value 1=SET, 0=RESET.

scrn= Screen number (1-8)
font= Font size (BIG or SMALL)
row= Screen row (1-3 for BIG, 1-6 for SMALL)
col= Screen column (1-20 for BIG, 1-40 for SMALL)

DISPLAY NESW takes the angular wind direction value in degrees from SLOC and displays it in terms of compass point descriptions: N, NNE, NE, ENE, E, etc. Allow 3 character spaces on display screen.

sloc= Source location
scrn= Screen number (1-8)
font= Font size (BIG or SMALL)
row= Screen row (1-3 for BIG, 1-6 for SMALL)
col= Screen column (01-20 for BIG, 01-40 for SMALL)

DISPLAY TEXT displays up to 25 text characters. Truncate to fewer than 25 characters by terminating with the '\ ' (backslash) character. Otherwise, all 25 characters will be displayed even if most are blanks.

scrn= Screen number (1-8)
row= Screen row (1-3 for BIG, 1-6 for SMALL)
col= Screen column (01-20 for BIG, 01-40 for SMALL)
text= Text to be displayed (up to 25 characters)
font= Font size (BIG or SMALL)

DISPLAY TIME displays time from the internal real time clock in hh:mm:ss format. Leap years are handled automatically.

scrn= Screen number (1-8)
font= Font size (BIG or SMALL)
row= Screen row (1-3 for BIG, 1-6 for SMALL)
col= Screen column (01-20 for BIG, 01-40 for SMALL)

DISPLAY VALUE displays the value in SLOC. WIDTH defines total character width on screen. DECPT defines the number of digits after the decimal point. Asterisks (*) are displayed if the value exceeds the defined WIDTH.

sloc= Source location (001-256)
scrn= Screen number (1-8)
font= Font size (BIG or SMALL)
row= Screen row (1-3 for BIG, 1-6 for SMALL)
col= Screen column (01-20 for BIG, 01-40 for SMALL)
width= Maximum number of characters (1-9)
decpt= Number of digits following decimal point (1-9)

ELSE is used with IF statements as a branch when the associated IF test is false. Only one ELSE statement can be used with an IF statement. ELSE statements other than the first will be ignored and an ELSE without a preceding IF statement will generate an error when PGM ERR HANDLE is set to STOP.

Example:
IF LOC 10 = 100.0
 BEEP 5
 LOC 10 = 0
ELSE
 LOC 10 = LOC 10 + 1.0
END IF

Count to 100 by 1s then beep and start over.

END IF marks the end of an IF block and must be used to conclude every IF statement. END IF without an IF will generate an error when PGM ERR HANDLE is set to STOP.

IMPORTANT NOTE ABOUT FLAGS:

FLAG 01 is a special flag that triggers result calculation for AVERAGE, MINIMUM, MAXIMUM and STANDARD DEVIATION instructions when they use the BLOCK method. The flag has no effect when the MOVING method is used.

FLAG SET is used to set a flag ON or OFF. Use flags to signify the occurrence of some event and trigger a response (see IF FLAG).

flag#= Flag number (01 to 16)
state= Flag state (ON or OFF)

FLAG SET MASK sets the state of all flags using a hexadecimal mask.

mask= Hexadecimal mask value (0000-FFFF)
state= Flag state (ON or OFF)

FLAG TIME INTERVAL sets the state of FLAG# when current time aligns with an interval. When UNIT is set to MIN (minute), TIME interval is limited to 1440 (equivalent to 24 hours). The PROGRAM INTERVAL parameter must be set to 00 or 01 for this instruction to operate correctly.

unit= Time unit (SEC or MIN)
time= Time alignment (0001-9999)
flag#= Flag number (01-16)
state= Flag state (ON or OFF)

IMPORTANT NOTE ABOUT IF INSTRUCTIONS:

All IF instructions must have a matching END IF instruction. Only one optional ELSE instruction may be inserted between them. Example:

```
IF FLAG
  instruction(s) ...
ELSE (optional)
  instruction(s) ... (optional)
END IF
```

IF FLAG tests whether FLAG# is ON or OFF.

flag#= Flag number (01-16)
state= Flag state (OFF or ON)

IF FLAG MASK tests all flags against a hexadecimal flag mask. LOGIC parameter determines whether ANY or ALL flags matching the mask will satisfy the condition. STATE parameter determines whether we are looking for ON flags or OFF flags as defined by the mask.

mask= Hexadecimal mask (0000 to FFFF)
logic= Match logic (ANY or ALL)
state= Comparison state (OFF or ON)

IF KEYSWITCH tests whether any of the 3 user soft-keys are pressed during OPERATE MODE.

key= Key value (KEY1, KEY2, or KEY3)

IF LOC1 COMPARE LOC2 compares the values in SLOC1 and SLOC2.

sloc1= Source location 1 (001-256)
comp: < less than
<= less than or equal to
>= greater than or equal to
> greater than
<> not equal to
= equal to
sloc2= Source location 2 (001-256)

IF LOC1 COMPARE VALUE compares the value in SLOC to a fixed value.

sloc1= Source location 1 (001-256)
comp: < less than
<= less than or equal to
>= greater than or equal to
> greater than
<> not equal to
= equal to
val= Value to compare

IF LOC SPAN tests the value in SLOC against two setpoint values. SPAN determines how to compare the value in SLOC to the range defined by SETPOINT 1 and 2. INCL (inclusive) compares SLOC to values inside the range. EXCL (exclusive) compares SLOC to values outside the range. DELAY sets the duration the compare condition must be met to consider the comparison true.

sloc= Source location (001-256)
set1= Setpoint 1
set2= Setpoint 2
delay= Time delay seconds (00-99)
span= Span logic (INCL or EXCL)

IF TIME INTERVAL tests current time to against a time interval. When UNIT is set to MIN (minutes), TIME interval is limited to 1440 (equivalent to 24 hours). The PROGRAM INTERVAL parameter must be set to 00 or 01 for this instruction to operate correctly.

unit= Time unit (MIN or SEC)
time= Time interval (0001-9999)

INPUT FREQ measures pulses per second on FREQ INPUT channels. LOW-AC configures the detector for a low-level AC signal. TTL/SW configures the detector for a TTL logic-level or switch-closure signal. Apply a multiplier and offset with MULT and OFFS if needed. Result stored in DLOC.

Switch-closures require a pull-up resistor. See appendix B for wiring examples.

chan= Frequency Input channel (1-4)
type= Input type (LOW-AC or TTL/SW)
mult= Multiplier value
offs= Offset value
dloc= Destination location (001-256)

INPUT PRECIP (TIPPING BUCKET) measures precipitation from a tipping bucket sensor using FREQ INPUT channels. RESO parameter sets the resolution per tip. Apply a multiplier with MULT if needed. Current 1-hour precipitation is stored at DLOC. Additional results are stored in six locations following DLOC. DO NOT allow other instructions to store values in these locations.

chan= Frequency input channel (1-4)
reso= Tip resolution
mult= Multiplier value
dloc= Destination location (001-256)
Current 1-hour precipitation
dloc+1 Last 1-hour precipitation
dloc+2 Current 24-hour precipitation
dloc+3 Last 24-hour precipitation
dloc+4 1-hour rate based on 5-minute sample
dloc+5 Rate total (used internally)
dloc+6 Raw pulse count (used internally)

INPUT PRECIP (SIPHON) measures precipitation from a YOUNG siphon-type precipitation sensor using a VOLTAGE INPUT CHAN. Set voltage measurement TYPE as single-ended (SE) or differential (DIFF). Set precipitation measurement UNIT to MM or INCH. Apply multiplier and offset with MULT and OFFS parameters if needed. Result is stored at DLOC.

```
chan= Voltage input channel (1-16)
type= Input type (SE or DIFF)
unit= Precipitation unit (MM or INCH)
mult= Multiplier value
offs= Offset value
dloc= Destination location (001-256)
```

INPUT SERIAL NMEA parses a NMEA sentence received on serial CHAN and stores results starting at DLOC. Numeric fields are stored as floating point numbers. Single-character ASCII-letter fields are stored as the equivalent decimal ASCII code. Example: 'A' = 65. HEADER text must match. WAIT defines the number of milliseconds to wait for an incoming NMEA string to appear. Parsing error codes are stored in the DLOC position just past the one used for the last field (dloc + #flds + 1).

```
chan= Serial I/O channel (COM1 or COM2)
header= NMEA sentence header (text)
#flds= Number of data fields in sentence (01-99)
wait= Milliseconds to wait for serial data (0000-9999)
dloc= First data field (001-256)

dloc+1 Second data field
dloc+2 Third etc.
...
dloc+flds+1 Error code
0 No Error
1 Header does not match
2 Bad checksum
5 Timeout
6 Asterisk not detected
7 No $ at beginning of sentence
8 Null field detected
```

All received serial sentences are stored in an internal buffer. If WAIT=0, new serial data will not be acquired. Instead, the existing buffer contents will be parsed. This scheme allows parsing for multiple headers by testing the error code for a match.

INPUT SERIAL NUM parses an ASCII text string received on serial CHAN and stores results starting at DLOC. #FLDS defines the number of data fields expected and will determine how many storage locations are used. DELIM defines the delimiter character between data fields in the string. ENDCHR defines the end-of-line characters. When ENDCHR is set to NONE, instruction will try to parse #FLDS. WAIT defines the number of milliseconds to wait for an incoming ASCII string to appear. The internal input buffer is limited to 128 characters.

```
chan= Serial I/O channel (COM1 or COM2)
#flds= Number of data fields in string (1-99)
delim= Field delimiter (SPACE, COMMA, TAB, NONE)
endchr= End-of-line characters (CR, CR-LF, NONE)
wait= Milliseconds to wait for serial data (0000-9999)
dloc= First data field (001-256)
dloc+1 Second data field
dloc+2 Third etc.
...
```

INPUT SERIAL RMYT parses the RMYT binary string received on serial CHAN and stores results starting at DLOC. UNITS defines wind speed units. WAIT defines the number of milliseconds to wait for an incoming RMYT string to appear.

```
chan= Serial I/O channel (COM1 or COM2)
units= Wind speed units (M/S, MPH, KM/H, KTS)
wait= Number of milliseconds to wait for serial data
dloc= Wind Speed destination location (001-256)
dloc+1 Wind direction destination location (001-256)
```

INPUT VOLTAGE measures voltage from 1 of 16 single-ended inputs or 7 differential inputs. Differential channels must always be set to an odd number to define the input pair (i.e. differential 5 means input pair 5 and 6). Use MULT and OFFS to apply a multiplier or offset to the measurement. RATE defines the sample rate. The default rate of 4800Hz provides the fastest measurement. Slower rates provide greater noise immunity and additional effective resolution. The result is stored in DLOC.

```
chan= Voltage input channel (01-16)
type= Input type (SE or DIFF)
mult= Multiplier
offs= Offset
rate= Sample Rate (3.52kHz to 6.875Hz in 10 steps)
dloc= Destination location (001-256)
```

INPUT WIND DIR (VOLTAGE) measures wind direction using any single-ended voltage input channel 1 through 4. Designed for direct connection to a potentiometer transducer in the listed YOUNG sensor models, this instruction automatically applies a compensated pull-down resistance to accommodate the potentiometer dead-band. Result in angular degrees is stored in DLOC.

```
chan= Input channel (1-4)
sensor= Young (03xxx, 04xxx, 051xxx, 053xxx, 05108)
dloc= Destination location (001-256)
```

INPUT WIND SPEED (FREQ) measures wind speed of listed YOUNG sensors using any FREQ INPUT channel 1 through 4. This instruction pre-configures the FREQ INPUT channel for low-level AC.

```
chan= Frequency input channel (1-4)
sensor= Young (03xxx, 04xxx, 051xxx, 053xxx, 05108)
units= Wind speed units (M/S, MPH, KM/H, KTS)
dloc= Destination location (001-256)
```

LOC1 = LOC2 assigns the value in LOC2 to LOC1.

```
loc1= Location 1 (001-256)
loc2= Location 2 (001-256)
```

LOC = VALUE assigns the number in VAL to LOC.

```
loc= Location 1 (001-256)
val= Numerical value
```

LOC1 = LOC2 OPER LOC3 performs a numerical operation using the values in LOC2 and LOC3 and stores the result in LOC1. POW raises the value in LOC2 to the power of the number in LOC3. MOD calculates the modulo using the value in LOC3.

```
loc1= Location where result is stored (001-256)
loc2= Location (001-256)
oper= Math operator (+, -, *, /, POW, MOD)
loc3= Location (001-256)
```

LOC1 = LOC2 OPER VALUE performs a numerical operation on the value in LOC2 using the number in VAL and stores the result in LOC1. POW raises the value in LOC2 to the power of VAL. MOD calculates modulo VAL.

loc1= Location where result is stored (001-256)
loc2= Location (001-256)
oper: Math operator (+, -, *, /, POW, MOD)
val= Numerical value

LOC1 = FUNCTION(LOC2) performs one of several complex functions on one or more values starting with LOC2 and stores the result in LOC1.

loc1= Location where first result is stored (001-256)
func: ABS Absolute value of number in LOC2
COS Cosine of number in LOC2
SIN Sine of number in LOC2
ATAN2 Standard atan2 function calculates arc-tan of two Cartesian numbers in sequential storage locations. Result is in degrees.
LOC2 = first value
LOC2+1 = second value
DEWPT Calculates dew point (°C) from RH% and temperature. Uses two sequential storage locations for input.
LOC2 = RH%
LOC2+1 = temperature (°C)
WETBULB Calculates wetbulb temperature (°C) from RH%, temperature, and pressure. Uses three sequential storage locations for input.
LOC2 = RH%
LOC2+1 = temperature (°C)
LOC2+2 = pressure (hPa or mB)
WNDCHLL Calculates wind chill temperature (°C) from ambient temperature and wind speed using standard NWS formula. Uses two sequential storage locations for input.
LOC2 = temperature (°C)
LOC2+1 = wind speed (m/s)
POLYNOM Calculates polynomial using the number in LOC2 and 5 coefficients in sequential storage locations. Result = $A + B*X + C*X^2 + D*X^3 + E*X^4$
LOC2= X
LOC2+1= A
LOC2+2= B
LOC2+3= C
LOC2+4= D
LOC2+5= E
RTD375 Calculates temperature of a 1000-ohm 3.75-alpha platinum RTD sensor using the ratio of RTD resistance to 1000 in LOC2. A value of 1.0000 represents 1000 ohms
LOC2= RTD ratio to 1000 ohms

RTD385 Calculates temperature of a 100-ohm 0.385-alpha platinum RTD sensor using the ratio of RTD resistance in LOC2. A value of 1.0000 represents 100 ohms.

LOC2= RTD ohms

P CORR Calculates sea level pressure correction in hPa when given altitude in meters. Add the correction to measured pressure to get sea level equivalent.

LOC2= altitude (meters)

ERRCODE Puts the ErrCode result of the previous instruction in LOC1. LOC2 is ignored. Values less than 200 correspond to the error code listed in section 6.0. Error code value >= 200 indicate incorrect instruction parameters.

DATETIME Stores the date and time in successive locations starting with LOC1.

LOC1= Year
LOC+1= Month
LOC+2= Day of Month
LOC+3= Hour
LOC+4= Minute
LOC+5= Second
LOC+6= 1/100th of a second

WAITFOR Waits until an interrupt-driven modulo counter matches the millisecond value in LOC2. The counter is updated every 5 milliseconds therefore the millisecond value should be a multiple of 5. The modulo counter is reset to zero once per second. A 25 millisecond delay is added to every User Program execution cycle.

LOC2= Milliseconds (5-995)

MAXIMUM finds the algebraically highest value in a group of samples taken from SLOC. #SAMP defines the number of samples for MOVING only.

BLOCK type progressively examines new samples and stores the current maximum in DLOC. When FLAG 1 is set, the maximum is stored in DLOC+1 and reset with the value in SLOC.

MOVING type maintains a list of #SAMP samples. DLOC and DLOC+1 are both set to the maximum value in the entire list. The maximum is updated with every new sample. Each new sample displaces the oldest sample on the list. The number of samples that can be maintained in the list is limited by available memory. If PGM ERR HANDLE is set to STOP, an error will be generated when #SAMP exceeds available memory.

sloc= Source location (001-256)
dloc1= Destination location(001-256)
type= Max type (BLOCK or MOVING)
#SAMP= Number of samples to examine (0001-7000)
Limited to available memory for MOVING MAX.

MINIMUM finds the algebraically lowest value in a group of samples taken from SLOC. #SAMP defines the number of samples for MOVING type only.

BLOCK type progressively examines new samples and stores the current minimum in DLOC. When FLAG 1 is set, the minimum is stored in DLOC+1 and reset with the value in SLOC.

MOVING type maintains a list of #SAMP samples. DLOC and DLOC+1 are both set to the minimum value in the entire list. The minimum is updated with every new sample. Each new sample displaces the oldest sample on the list. The number of samples that can be maintained in the list is limited by available memory. If PGM ERR HANDLE is set to STOP, an error will be generated when #SAMP exceeds available memory.

sloc= Source location (001-256)
dloc1= Destination location(001-256)
type= Min type (BLOCK or MOVING)
#SAMP= Number of samples to examine (0001-7000)
Limited to available memory for MOVING MAX.

OUTPUT MILLIAMPS produces output current in 1 of 4 analog output channels using the value in SLOC. MULT and OFFS may be used to scale the SLOC value with a multiplier and offset. Output current is limited to 0.00 to 20.00 mA.

sloc= Source location (001-256)
chan= Analog output channel (1-4)
mult= Multiplier
offs= Offset

OUTPUT MILLIVOLTS produces output voltage in 1 of 4 analog output channels using the value in SLOC. MULT and OFFS may be used to scale the SLOC value with a multiplier and offset. Output voltage is limited to 0 to 5000 mV.

sloc= Source location (001-256)
chan= Analog output channel (1-4)
mult= Multiplier
offs= Offset

OUTPUT SWITCH sets the state of 1 of 4 SOLID STATE SWITCH channels.

chan= Solid state switch channel (1-4)
state= State of switch (ON or OFF)

IMPORTANT NOTE ABOUT RECORD INSTRUCTIONS:

RECORD TIME and RECORD VALUE instructions store data to an internal serial flash device. Up to 2,162,688 single-precision floating point data values may be recorded. The storage scheme is one large circular buffer with each RECORD instruction storing data in the next available location. When the end of memory is reached, the internal index starts back at the beginning.

RECORD TIME records TIME or DATE to internal flash memory. DATE is encoded as a large integer. For example, 2008 May 27 is stored as 20080527. TIME is similarly stored in hundredths of a second. For example, 15:23:07.00 is stored as 15230700. RMYComm can retrieve these values and convert them to conventional form.

frmt= Record format (DATE or TIME)

RECORD VALUE records the number stored in SLOC to internal flash memory.

sloc= Source location (001-256)

IMPORTANT NOTE ABOUT SERIAL INSTRUCTIONS:

All SERIAL BUFFER instructions (except SERIAL BUFFER OUT) add ACSII text to the serial output buffer. An internal buffer index increments with each new character added. This process continues until the 128-character buffer size limit is reached or a SERIAL BUFFER OUT instruction is executed. If the buffer limit is reached, no further text will be added and generate an error if PGM ERR HANDLE is set to STOP. Any USER PROGRAM that adds text to the serial buffer should always include a SERIAL BUFFER OUT instruction. After executing a SERIAL BUFFER OUT instruction, the internal index is reset to the beginning of the output buffer.

SERIAL BUFFER CHECKSUM calculates a checksum based on the contents of the serial output buffer and places it at the end. TYPE may be set to SIMPLE, CRC32, or NMEA. SIMPLE uses the arithmetic sum of ASCII values to produce a 5-digit integer. CRC32 uses CRC-32-IEEE 802.3 to produce an 8-character hex value. NMEA produces a marine NMEA 0183 standard checksum presuming that the sentence meets all other NMEA formatting requirements.

type= Checksum type (SIMPLE, CRC32, or NMEA)

SERIAL BUFFER NESW takes angular wind direction (in degrees) from SLOC, translates it to a compass point description (N, NNE, NE, ENE, E, etc...), and adds the 3-character string to the serial output buffer. DELIM defines the delimiter to be placed at the end of the field.

sloc= Source location
delim= Field delimiter (SPACE, COMMA, TAB, NONE)

SERIAL BUFFER OUT transmits the contents of the serial output buffer through serial CHAN COM1 or COM2. ENDCHR defines the termination characters sent at the end of the transmission. DELAY defines the number of milliseconds after transmission before the instruction continues program execution. After transmission, the internal output buffer index is reset to the beginning.

chan= Serial I/O channel (COM1 or COM2)
endchr= Termination characters (CR, LF, NONE)
delay= Millisecond delay (00-99)

SERIAL BUFFER TEXT adds up to 25 alpha-numeric characters to the to the serial output buffer.

Sample Text String= Sensor#69

SER BUF TIME adds TIME or DATE text to the serial output buffer. FRMT determines whether DATE or TIME is used. DATE produces yy-mm-dd (yy= year, mm=month, dd=day). TIME produces hh:mm:ss (hh=hour, mm=minute, ss=seconds). DELIM defines the delimiter placed at the end of the field.

frmt= DATE or TIME
delim= Field delimiter (SPACE, COMMA, TAB, NONE)

SERIAL BUFFER VALUE adds the number in SLOC to the serial output buffer. WIDTH defines the total character width, DECPT defines the number of digits after the decimal point. DELIM defines the field delimiter inserted at the end.

sloc= Source location
width= Number of characters
decpt= Number of digits after decimal point
delim= Field delimiter (SPACE, COMMA, TAB, NONE)

STANDARD DEVIATION calculates the standard deviation of samples from SLOC and stores the result in DLOC. #SAMP defines the number of samples for MOVING type only.

BLOCK type adds new values with each instruction iteration. When FLAG 1 is ON, the standard deviation is calculated. The process begins again when FLAG 1 is OFF.

MOVING type keeps a list of every sample. After #SAMP samples have been collected, the first standard deviation is calculated. After that, a new standard deviation is calculated for each new sample acquired. Each MOVING standard deviation instruction automatically allocates the needed internal memory. If memory limits are reached and PGM ERR HANDLE is set to STOP, an error message will appear.

ANGLE types internally convert unit vector angles to Cartesian values which are used for the actual calculation. Internal Cartesian standard deviations are converted back to angles for the final result. MOVING ANGLE employs the Yamartino algorithm.

sloc= Source location
dloc= Destination location
type= BLOCK, BLK ANGLE, MOVING, MOV ANGLE
#samp= Number of samples (0001-1750)

WIND DIRECTION 0-540 converts 0-360° wind direction in SLOC (degrees) to a 0-540° range stored in DLOC. When used to produce an analog output, the 0-540° range helps prevent chart "painting" or excessive zero-to-full-scale excursions when the wind direction oscillates about the 0/360° transition.

sloc= Source location (001-256)
dloc= Destination location (001-256)

5.0 SERIAL COMMUNICATION

The 26800 includes two independent serial communication channels: COM1 and COM2. COM1 may be set to operate as either an RS-232 or RS-485 port. Baud rates for either channel may be set to any of several common values between 1200 and 230.4K baud. Format is 8 bits data, 1 stop, no parity. No handshaking is used.

Either serial channel may be controlled by the USER PROGRAM for input or output using INPUT SERIAL and SERIAL BUFFER instructions.

The USB port is dedicated to communication with RMYComm, the included Windows PC program used to manage setup parameters, static screen text, the user program, and recorded data.

6.0 ERROR MESSAGES

When an error occurs during OPERATE MODE and PGM ERR HANDLE is set to STOP, the 26800 generates an error message and takes the user to the offending instructions with an option to edit.

- 1 DIVIDE BY 0 ERROR IN INSTR N**
Zero value in temporary storage instruction LOC used as a divisor in this instruction.
- 2 INVALID ARGUMENT IN INSTR N**
Serial input string is invalid or screen number in temporary storage location is invalid.
- 3 BUFFER OVERRUN ERROR IN INSTR N**
Auto-incrementing index for serial output has exceeded 64-character buffer length limit.
- 4 END-IF WITHOUT IF ERROR IN INSTR N**
Each END-IF must be preceded by a matching IF statement.
- 5 ELSE WITHOUT IF ERROR IN INSTRUCTION N**
Each ELSE statement must be preceded by a matching IF statement.
- 6 CORRUPT USER PROGRAM IN INSTR N**
Reload the user program.
- 7 TIMEOUT IN INSTRUCTION N**
Determine cause. Increase PGM INTERVAL and/or TIMEOUT INTERVAL if needed.
- 8 UNKNOWN ERROR IN INSTRUCTION N**
Review USER PROGRAM.

7.0 WARRANTY

This product is warranted to be free of defects in materials and construction for a period of 12 months from date of initial purchase. Liability is limited to repair or replacement of defective item. A copy of the warranty policy may be obtained from R. M. Young Company.

APPENDIX A

SPECIFICATIONS - 26800 METEOROLOGICAL TRANSLATOR

General

Dimensions..... 200 mm (7.8 in) x 144 mm (5.7 in) x 54 mm (2.1 in)
Panel Cutout..... 194 mm (7.6 in) x 138 mm (5.4 in)
Weight..... 0.8 kg (1.8 lb)
Operating Temperature... 0° C to 50° C
Storage Temperature..... -30° C to 50° C
Housing Classification.... IP52

Display

Adjustable high-brightness, high-contrast with 8 user programmable screens
Large font capacity: 3 rows x 20 characters per screen
Small font capacity: 6 rows x 40 characters per screen
Both font sizes may be used together on the same screen

Power

Nominal 12 VDC at 190 mA with mid-level backlight
10 to 30 VDC at 2.4 W max
Terminals or coaxial jack for included AC-power adapter

Memory

2,162,688 Single-Precision floating point values for data records
256 Temporary floating point values for user programs
1 to 512 User Program Instructions

Voltage Input

Channels 7 differential or 16 single-ended inputs in any combination
Measurement Range -5000 to +5000 mVDC
Resolution 16 bits minimum
Conversion Rate 4.7 Hz to 4800 Hz in 10 steps
50/60 Hz Rejection Greater than 90 db at 4.7 Hz sampling rate
Accuracy 0.1%, 0 to 40° C

Pulse / Frequency Input

Channels 4 Inputs for Low Level AC or Switch Closure/TTL
Range 0 to 2500 Hz
Threshold 50 mVp-p for Low Level AC input
2500 mVDC for Switch closure/TTL

Excitation

Channels 2 Outputs. Regulated 5 VDC reference voltage at 10 mA

Voltage / Current Output

Channels 4 Outputs as voltage or current output.
Range Voltage 0 to 5000 mVDC. Current 0 to 20mA
Resolution 1 in 4000 (1.25 mV or 0.005mA)

Serial I/O

Channels COM1 and COM2. COM1 may be configured for either RS-232 or RS-485. COM2 is always RS-485. Both channels are full duplex, no handshake, 1 start, 8 data, 1 stop, no parity. 1200 to 230.4K

Switch Output

Channels 4 Solid State Switch outputs
Rating 60 VDC at 5A per switch.

Other

Compliance Complies with applicable CE directives

APPENDIX B

DC POWER SUPPLY TYPICAL WIRING CONNECTIONS

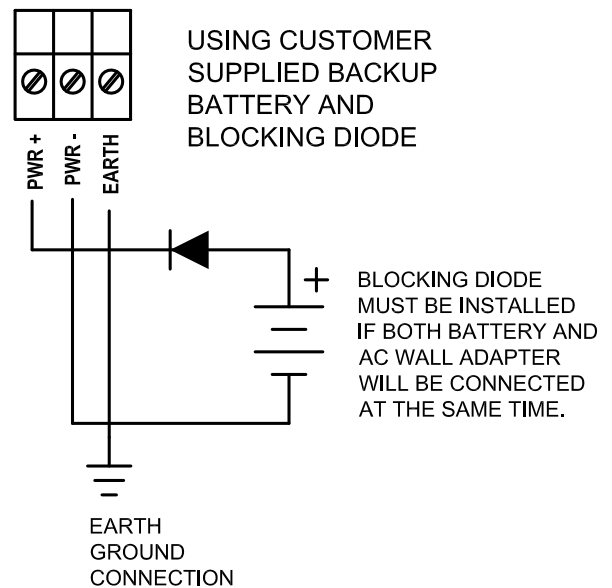
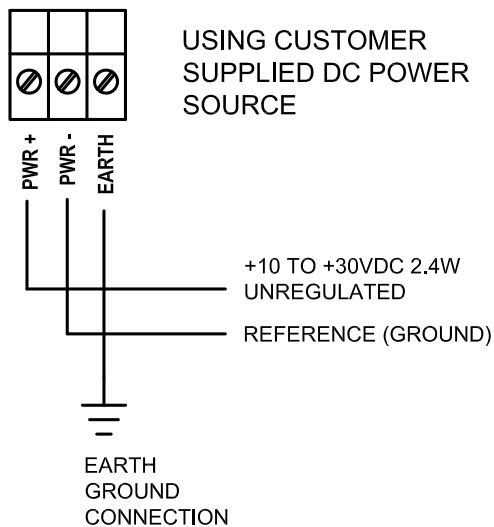
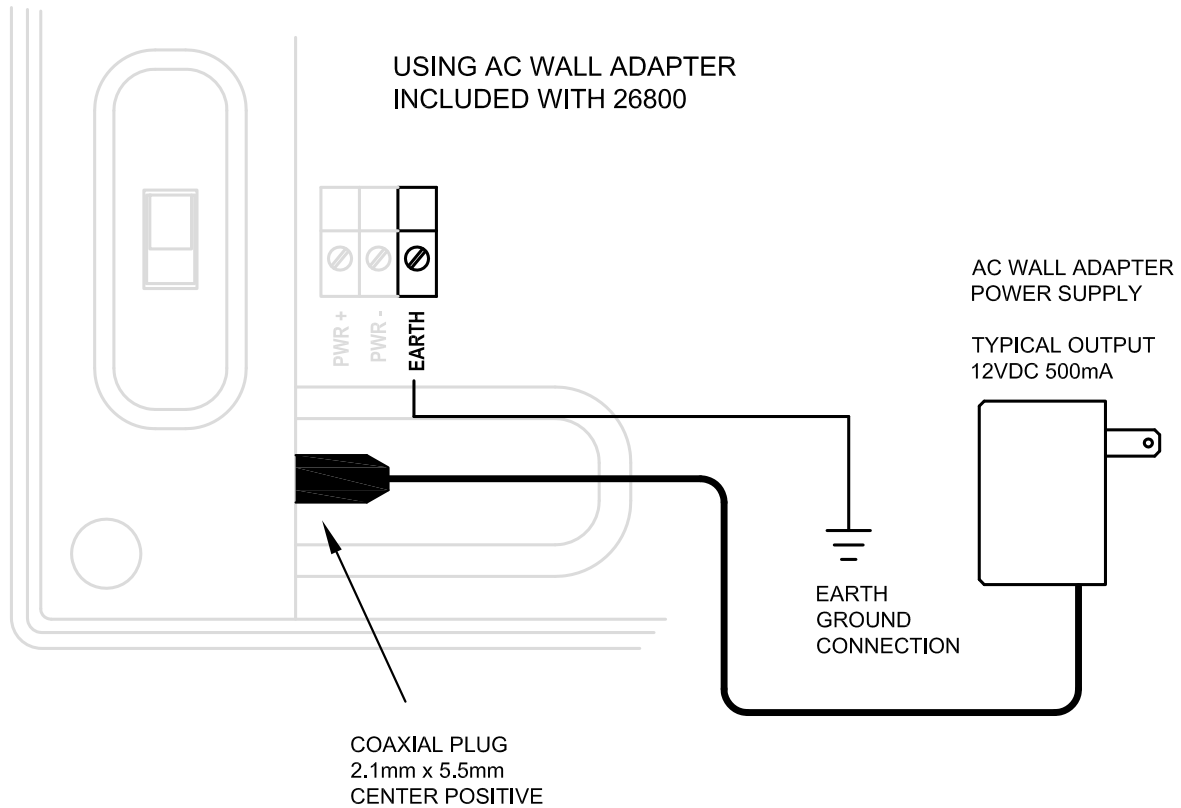

EARTH GROUND CONNECTION IS NEEDED TO
CONFORM WITH EMI REQUIREMENTS AND HELP
PROTECT DEVICE FROM ELECTRICAL TRANSIENTS.

APPENDIX B

SINGLE ENDED (SE) VOLTAGE INPUT MEASUREMENTS TYPICAL WIRING CONNECTIONS

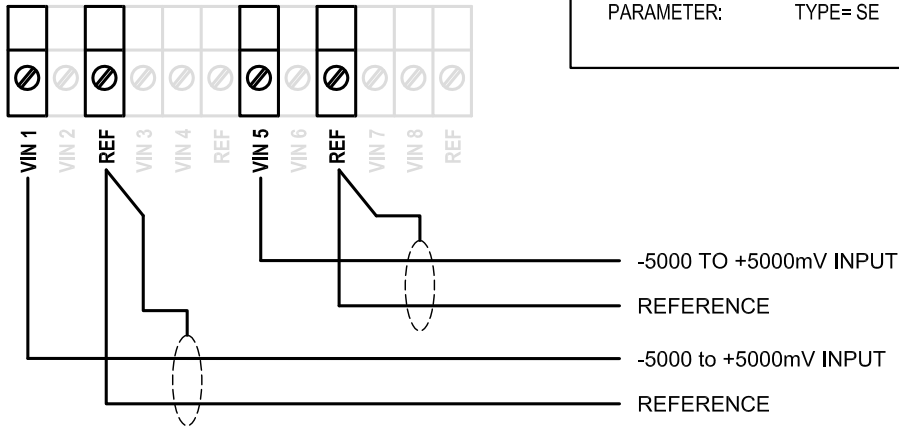

ACCURACY 0.1%
RESOLUTION 24-BITS AT 6.875Hz
50-60Hz NOISE -90dB AT 6.875Hz

VIN 1 to 16 RANGE -5000 to 5000mV
INPUT IMPEDANCE 10^{12} OHMS

PGM INSTRUCTION: INPUT VOLTAGE
PARAMETER: TYPE= SE

DIFFERENTIAL (DIFF) VOLTAGE INPUT MEASUREMENTS TYPICAL WIRING CONNECTIONS

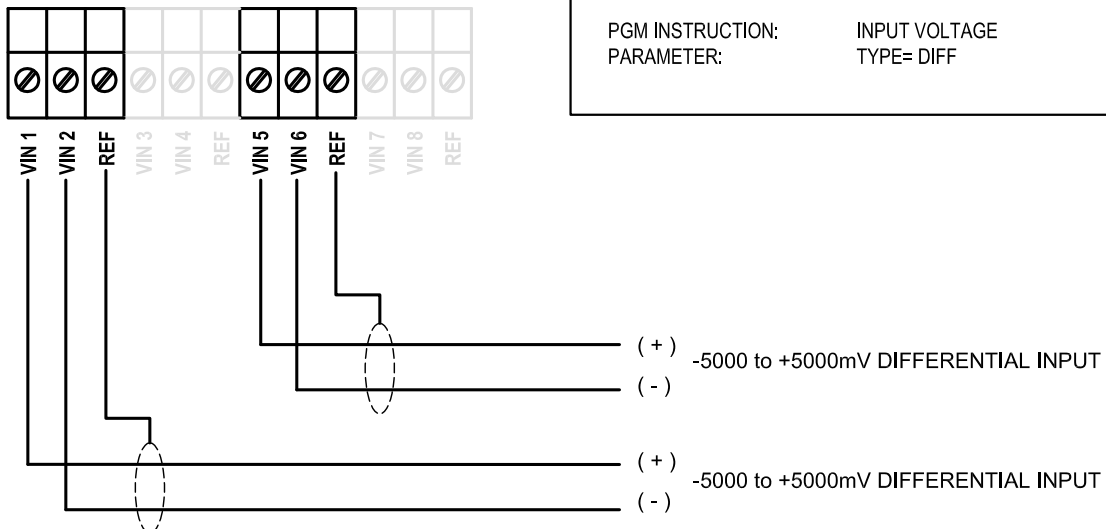

ACCURACY 0.1%
RESOLUTION 24-BITS AT 6.875Hz

VIN 1 to 16 RANGE -5000 to 5000mV
INPUT IMPEDANCE 10^{12} OHMS
COMMON MODE VOLTAGE -6 to +6VDC

DIFFERENTIAL INPUTS MUST BE USED IN PAIRS.

PGM INSTRUCTION: INPUT VOLTAGE
PARAMETER: TYPE= DIFF

APPENDIX B

FREQUENCY INPUT: PULSE, TTL, OR SWITCH CLOSURE TYPICAL WIRING CONNECTIONS

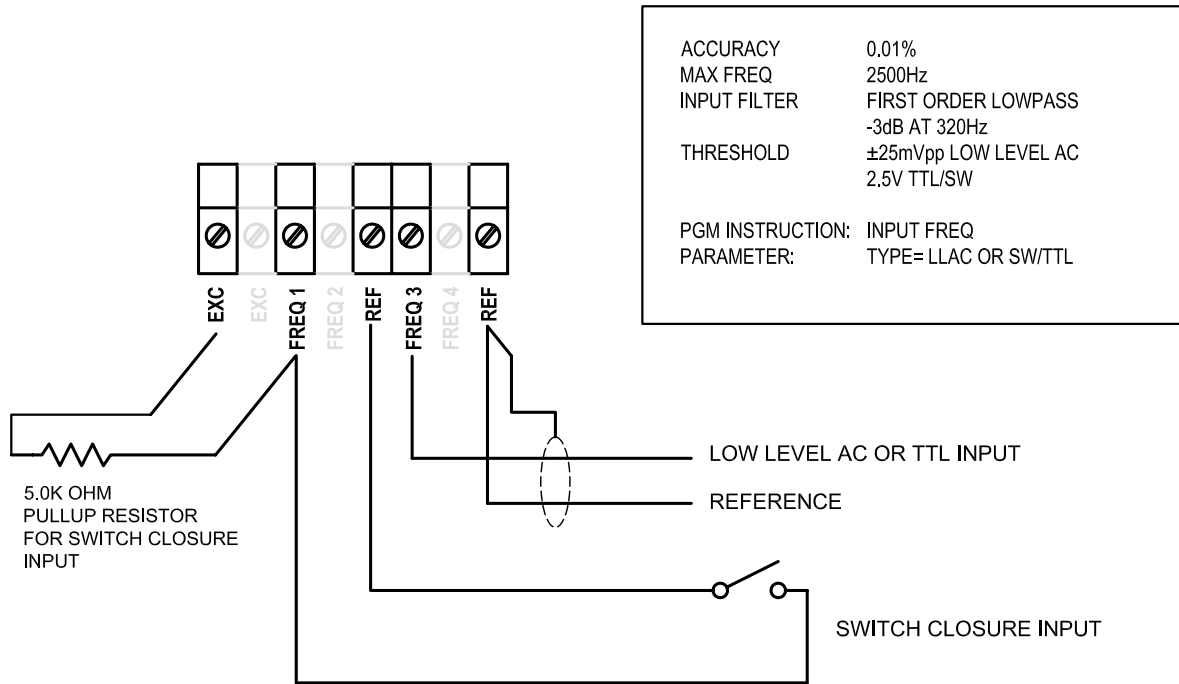

SOLID STATE SWITCH OUTPUTS TYPICAL WIRING CONNECTIONS

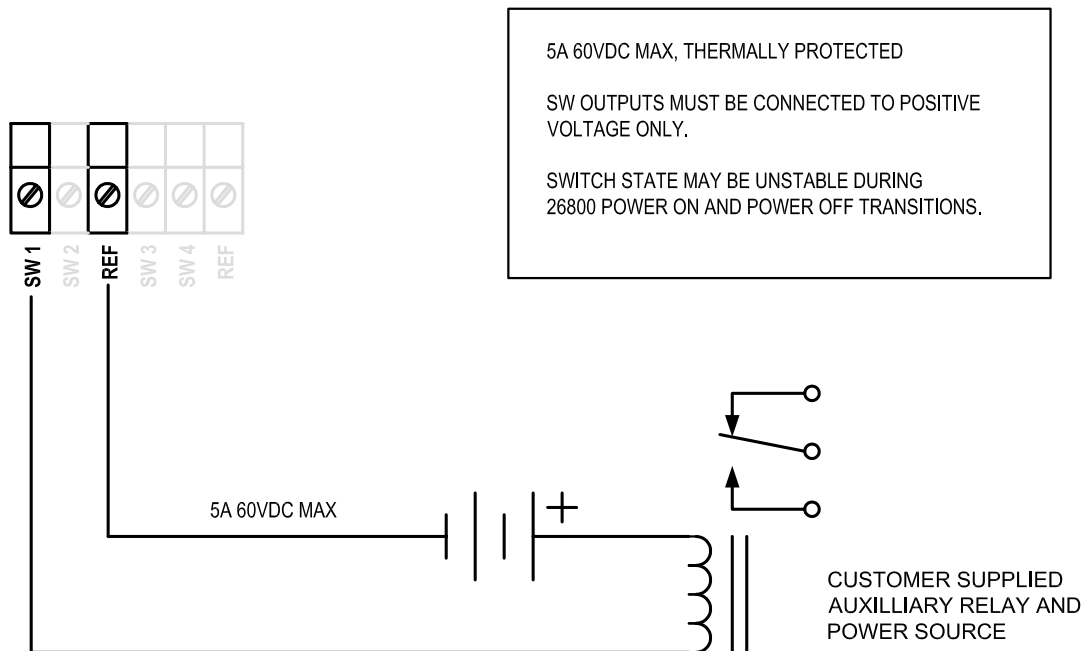

APPENDIX B

ANALOG OUTPUTS TYPICAL WIRING CONNECTIONS

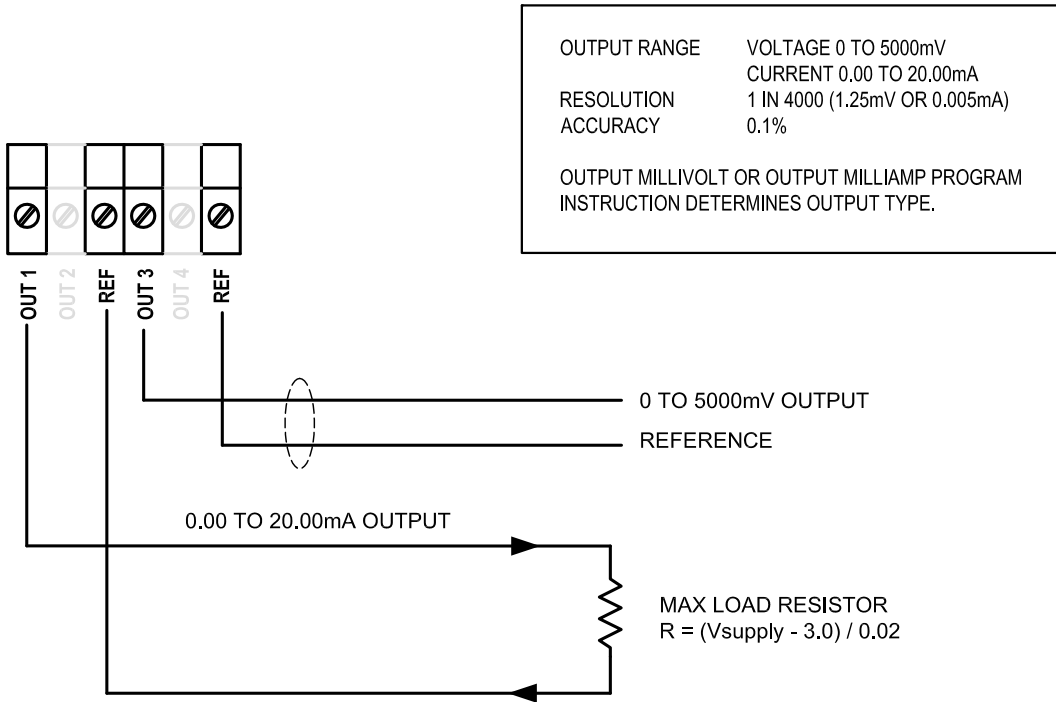

RS-232 AND RS-485 I/O TYPICAL WIRING CONNECTIONS

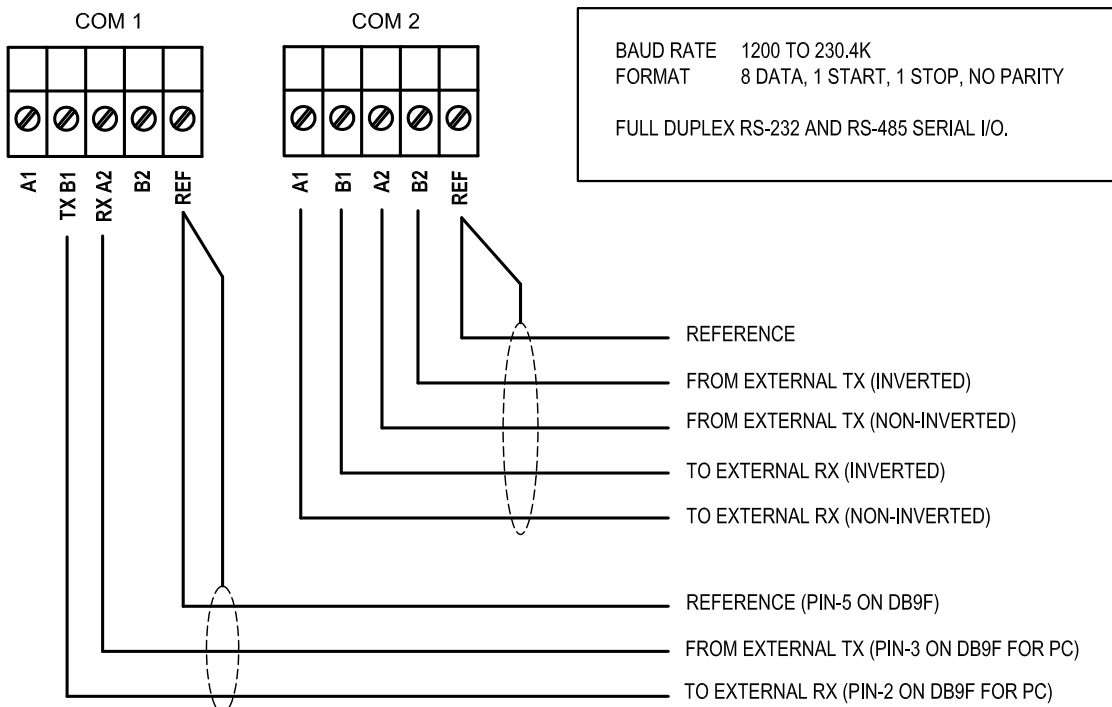

APPENDIX B

05103, 05305 WIND MONITOR TYPICAL WIRING CONNECTIONS

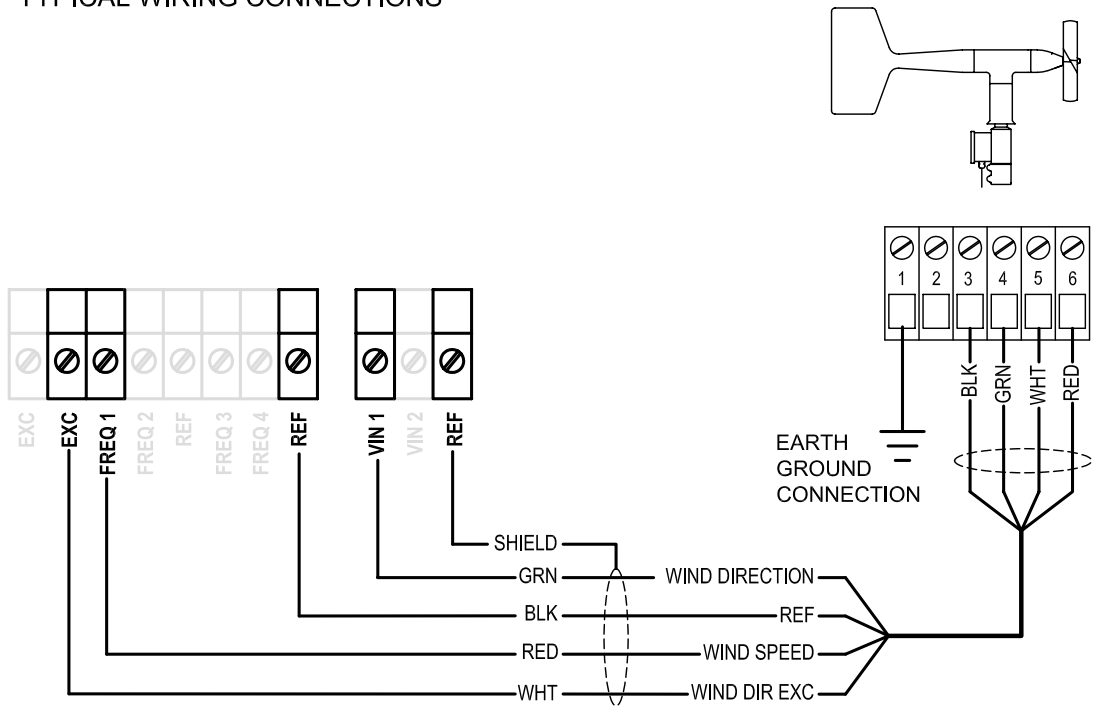

05106 MARINE WIND MONITOR TYPICAL WIRING CONNECTIONS

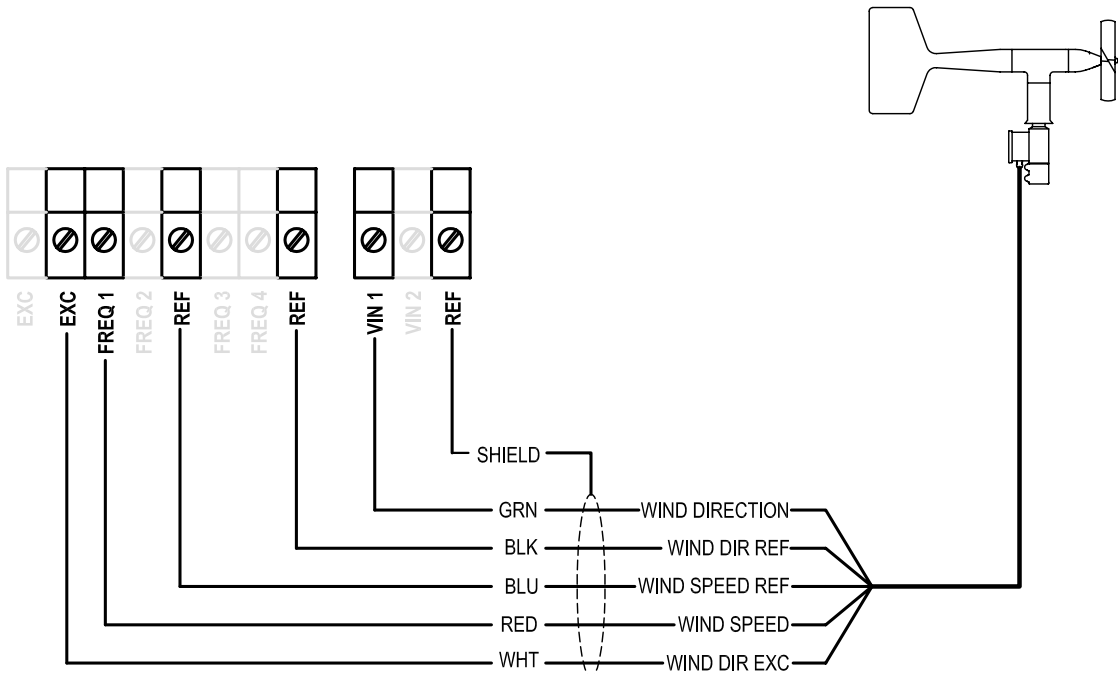

APPENDIX B

05103L, 05305L WIND MONITOR WITH 4-20mA OUTPUTS TYPICAL WIRING CONNECTIONS

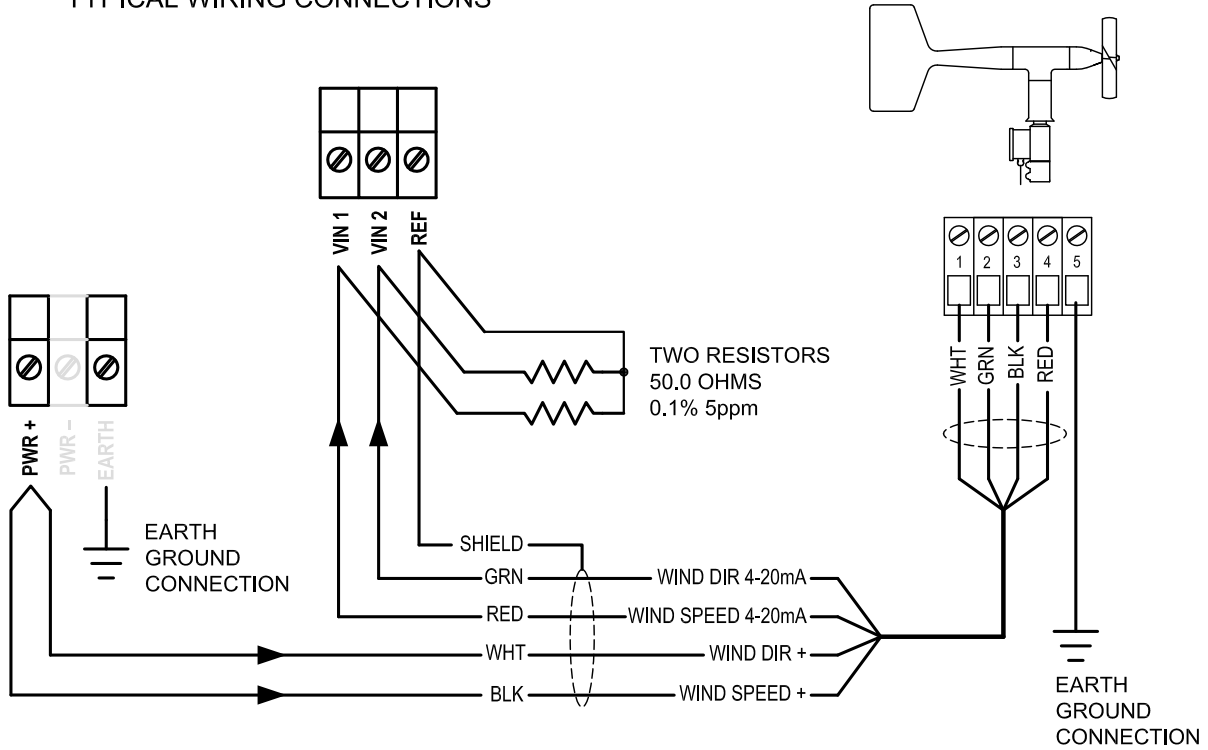

05106 WIND MONITOR MA WITH LINE DRIVER TYPICAL WIRING CONNECTIONS

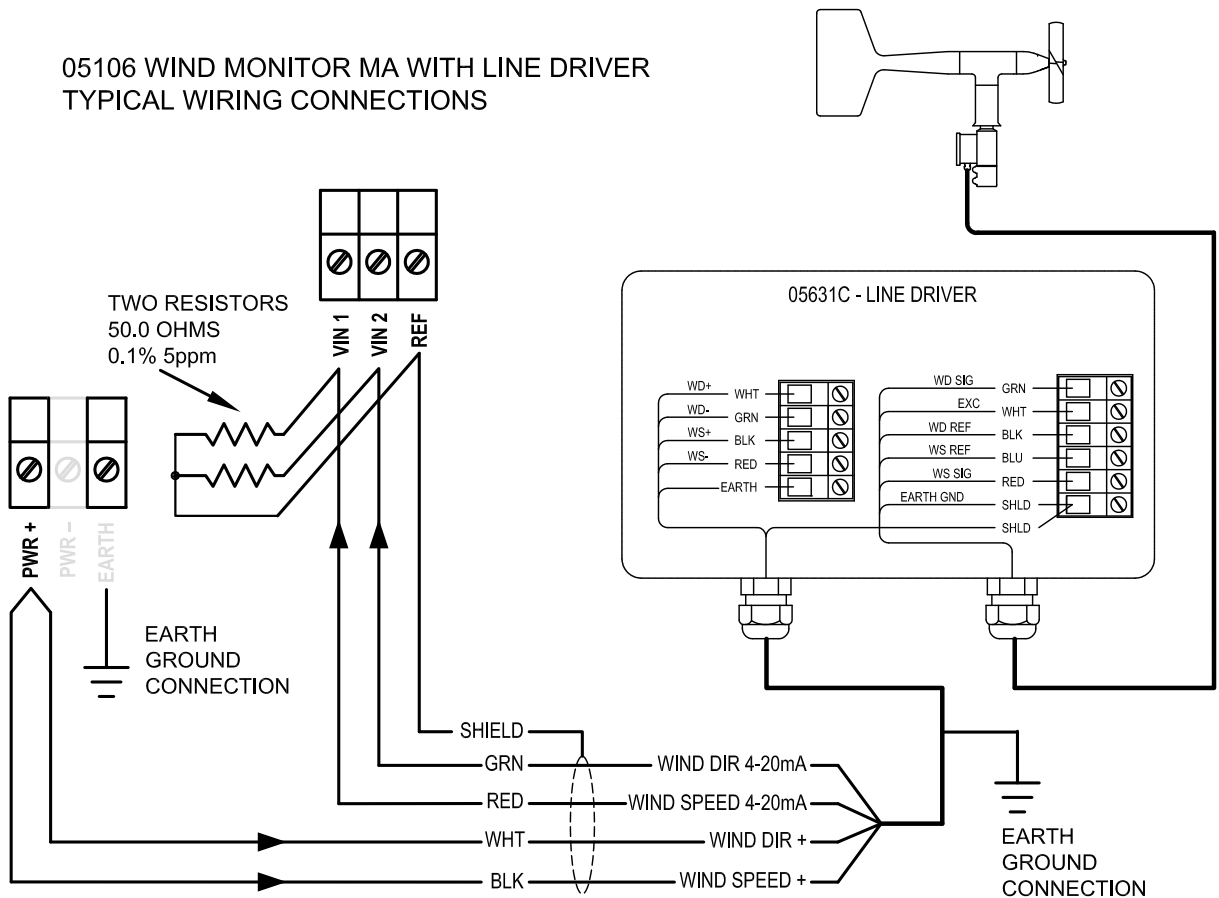

APPENDIX B

27106 PROPELLER ANEMOMETER TYPICAL WIRING CONNECTIONS

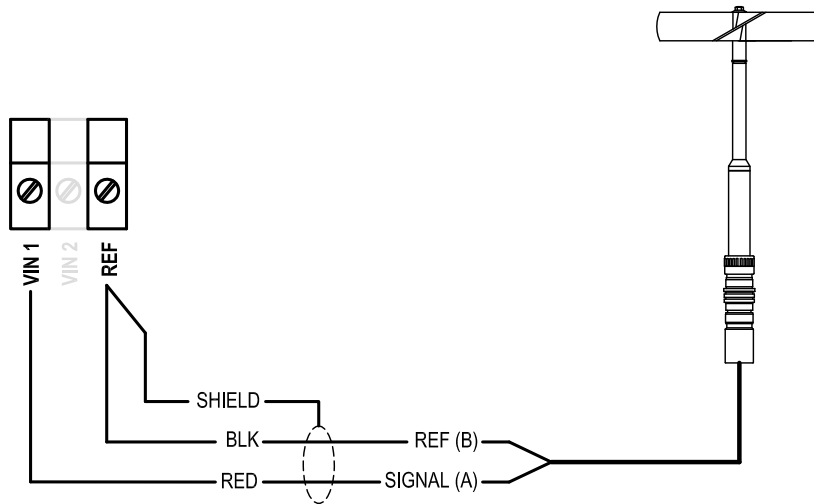

12002, 12005 GILL MICROVANE AND 3-CUP ANEMOMETER TYPICAL WIRING CONNECTIONS

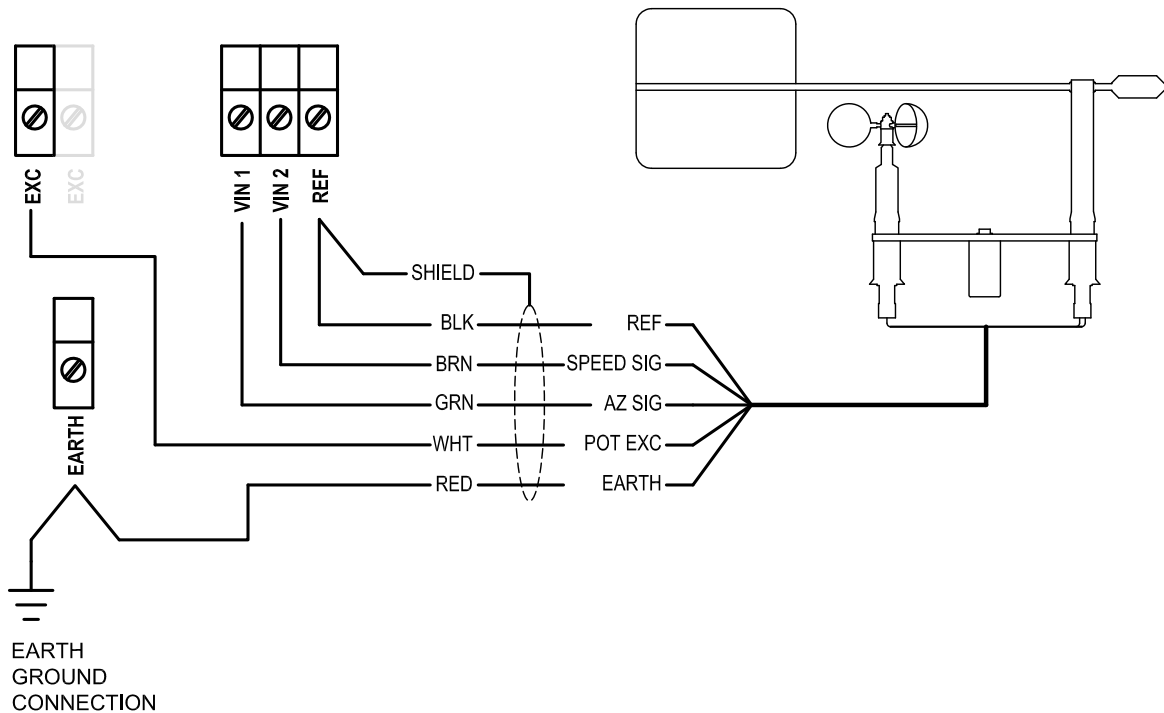

86000 FAMILY SONIC ANEMOMETER WITH FULL-DUPLEX SERIAL RS-485 TYPICAL WIRING CONNECTIONS

SENSOR SETTINGS
 RS-485
 Output Mode: RMYT - 86000
 NMEA - 86106

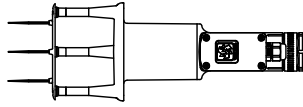

Model 86000 / 86106
 Ultrasonic Anemometer

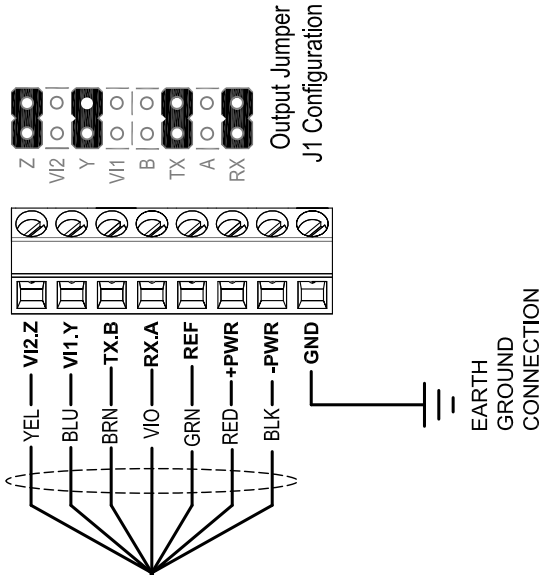

IF 86000 IS CONFIGURED FOR OUTPUT ONLY, 26800 CONNECTIONS A1 AND B1 MAY BE OMITTED.
 BAUD RATE MUST MATCH IN BOTH DEVICES.

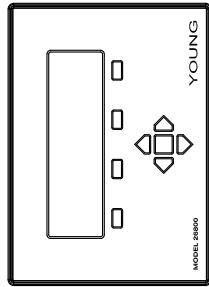

Model 26800 Translator

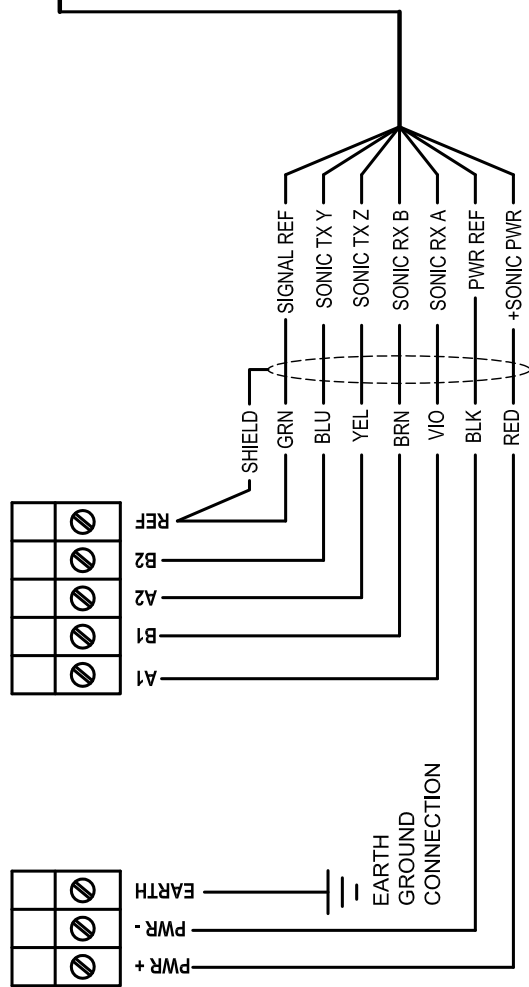

86000 FAMILY SONIC ANEMOMETER WITH VOLTAGE OUTPUTS TYPICAL WIRING CONNECTIONS

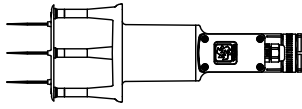

Model 86000 / 86106
Ultrasonic Anemometer

SENSOR SETTINGS
 Output Mode: VOUT
 WD Output Scale: 0-360
 Wind Format: Polar
 Analog Output Error Code: High

CALIBRATION:
 Polar Wind Speed: 0 to 5000 mV
 Wind Direction: 0 to 100 m/s
 0 to 360°

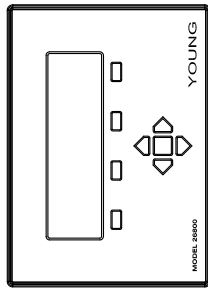

Model 26800 Translator

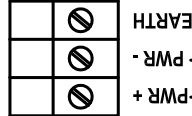

EARTH
GROUND
CONNECTION

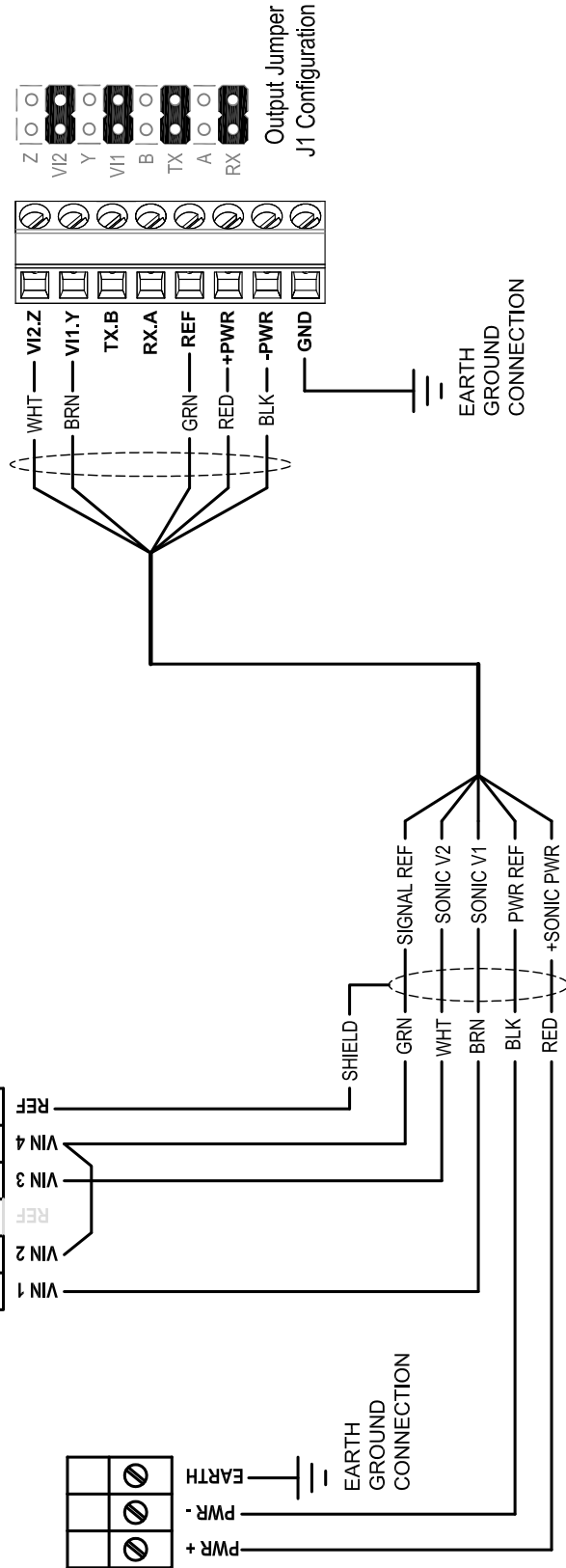

APPENDIX B

81000 FAMILY SONIC ANEMOMETER WITH FULL-DUPLEX SERIAL RS-485 TYPICAL WIRING CONNECTIONS

81000 FAMILY SONIC ANEMOMETER WITH FULL-DUPLEX SERIAL RS-485 TYPICAL WIRING CONNECTIONS

AC WALL ADAPTER SUPPLIED WITH 26800 MAY ALSO
POWER 81000 SONIC ANEMOMETER AS SHOWN IN
DRAWING.
BAUD RATE MUST MATCH IN BOTH DEVICES.

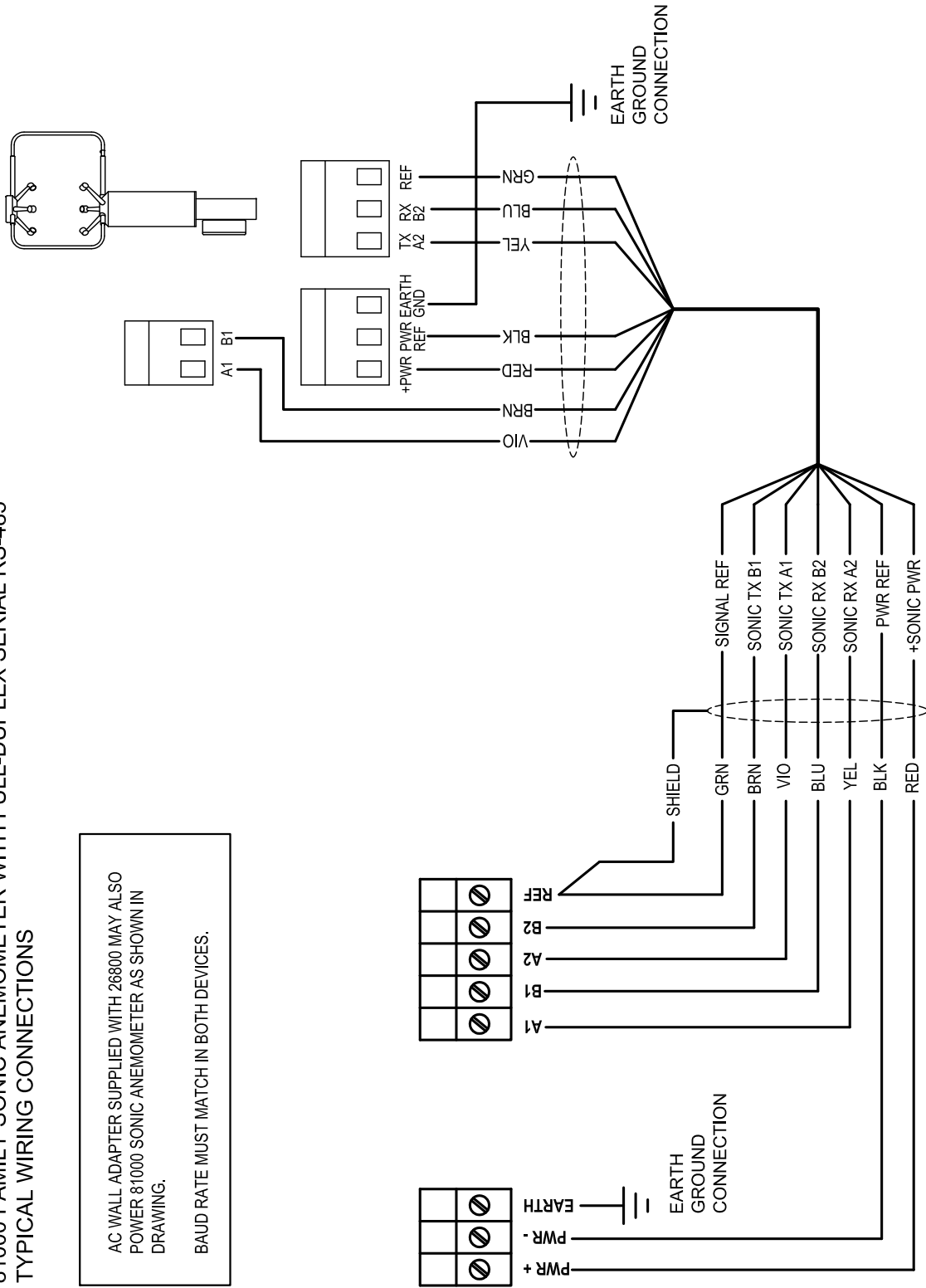

81000 FAMILY SONIC ANEMOMETER WITH VOLTAGE OUTPUTS TYPICAL WIRING CONNECTIONS

AC WALL ADAPTER SUPPLIED WITH 26800 MAY ALSO POWER 81000 SONIC ANEMOMETER AS SHOWN IN DRAWING.

SONIC MUST BE CONFIGURED FOR VOLTAGE OUTPUT: SPEED, AZIMUTH, ELEVATION AND SONIC TEMP OR U, V, W, AND SONIC TEMP.

DIFFERENTIAL VOLTAGE MEASUREMENTS MUST BE USED FOR EACH SIGNAL.

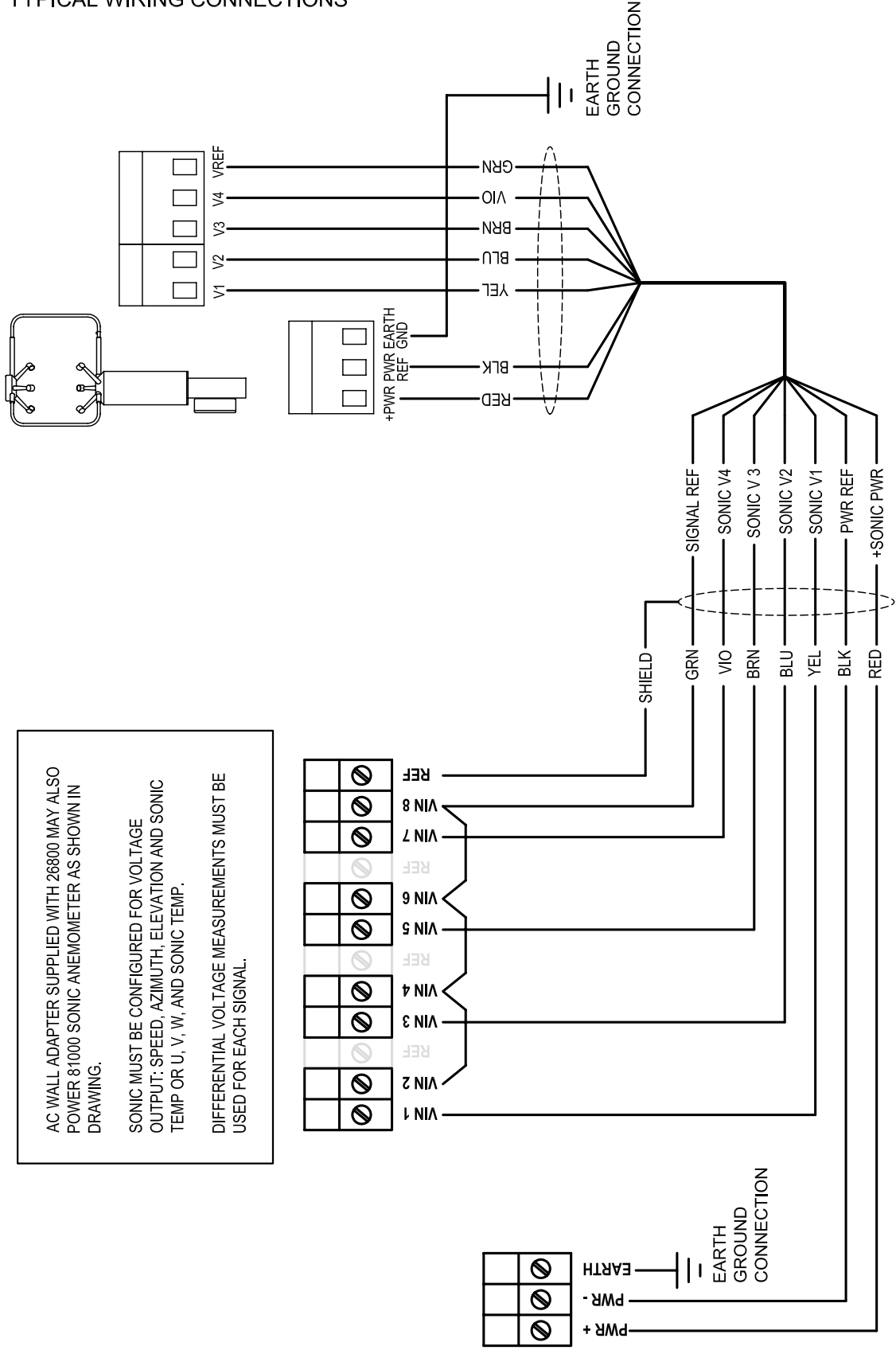

APPENDIX B

81000 FAMILY SONIC ANEMOMETER WITH VOLTAGE OUTPUTS TYPICAL WIRING CONNECTIONS

APPENDIX B

41382V TEMPERATURE / RH SENSOR WITH VOLTAGE OUTPUTS TYPICAL WIRING CONNECTIONS

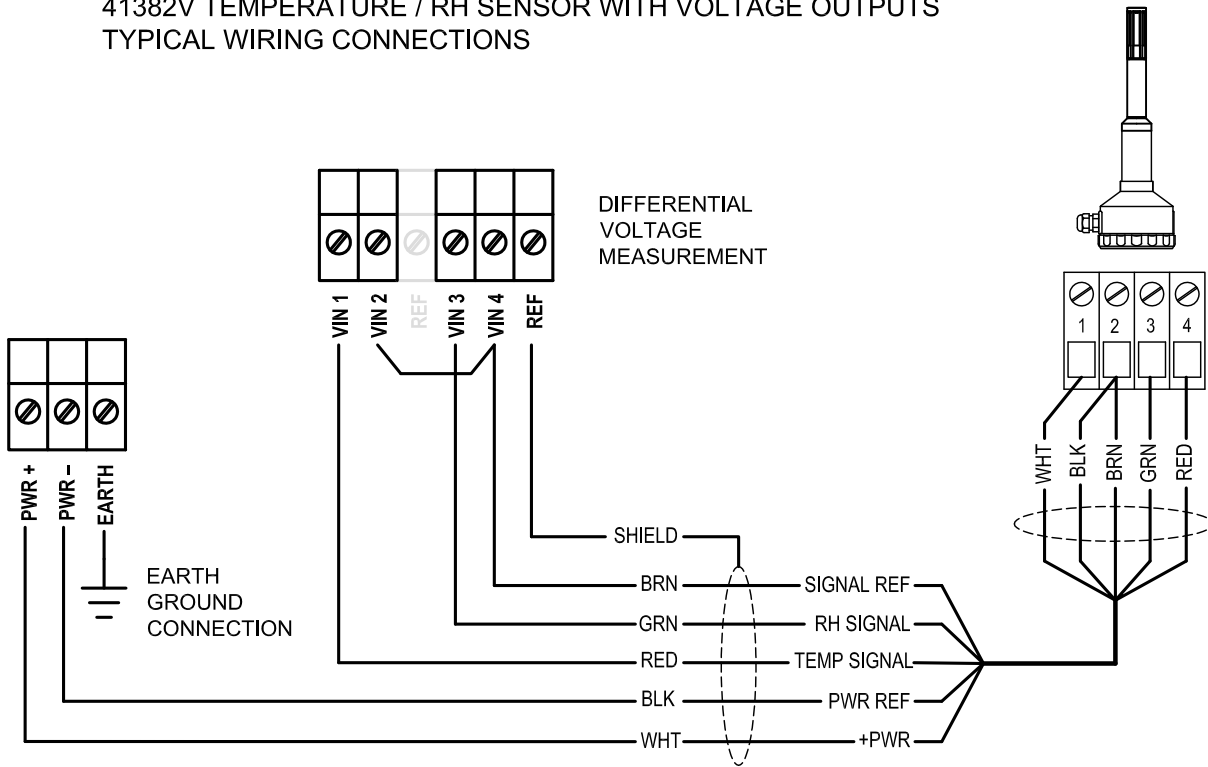

41382LC2 / 41382LF2 TEMPERATURE / RH SENSOR WITH 4-20mA OUTPUTS TYPICAL WIRING CONNECTIONS

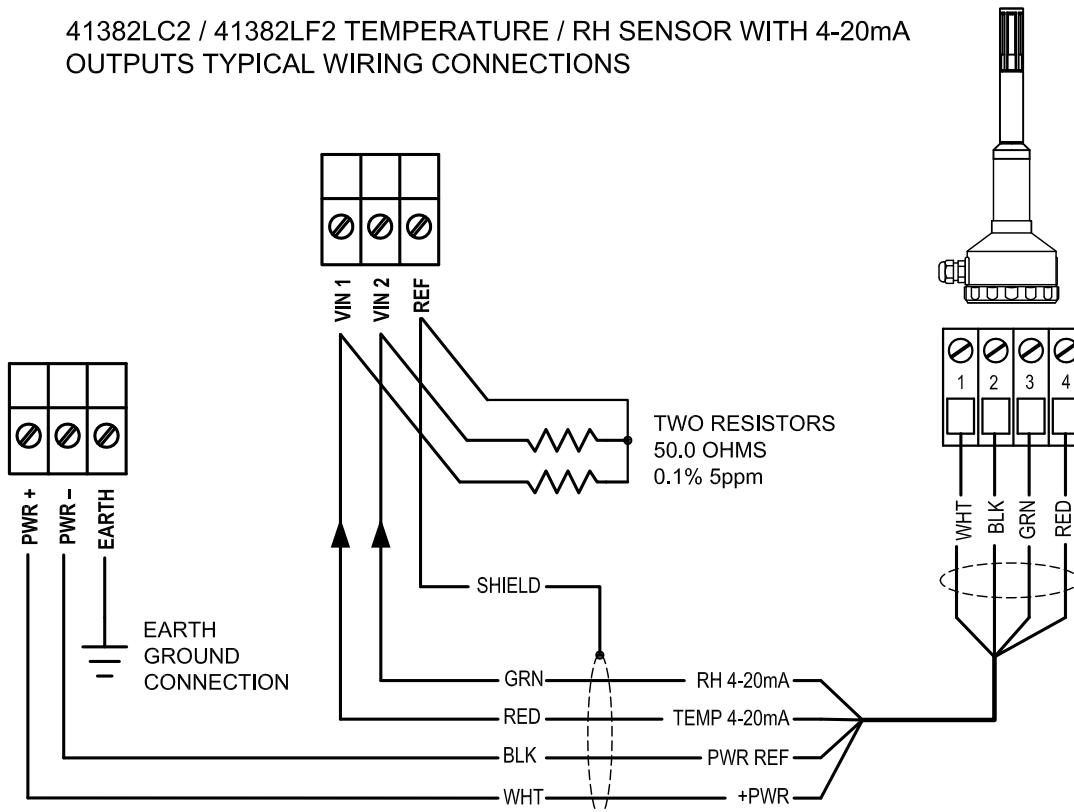

APPENDIX B

41342 PLATINUM RTD TEMPERATURE PROBE TYPICAL WIRING CONNECTIONS

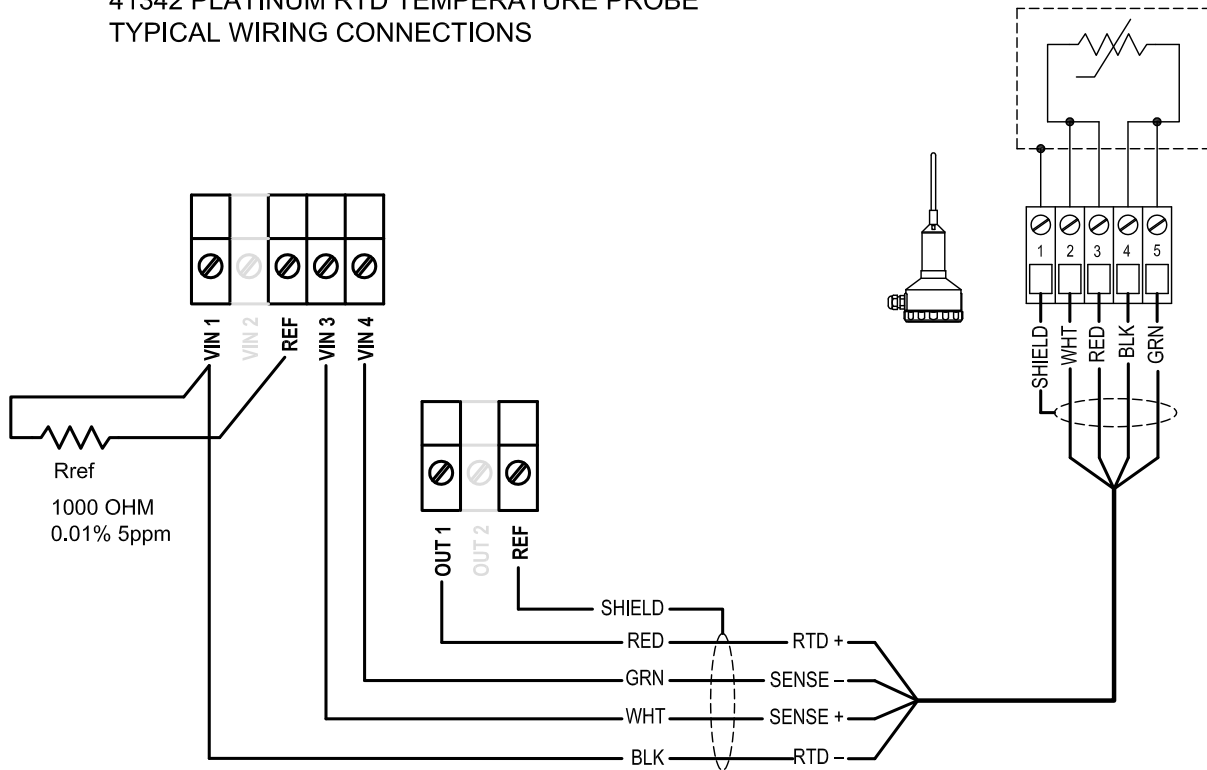

61302V BAROMETER WITH VOLTAGE OUTPUT TYPICAL WIRING CONNECTIONS

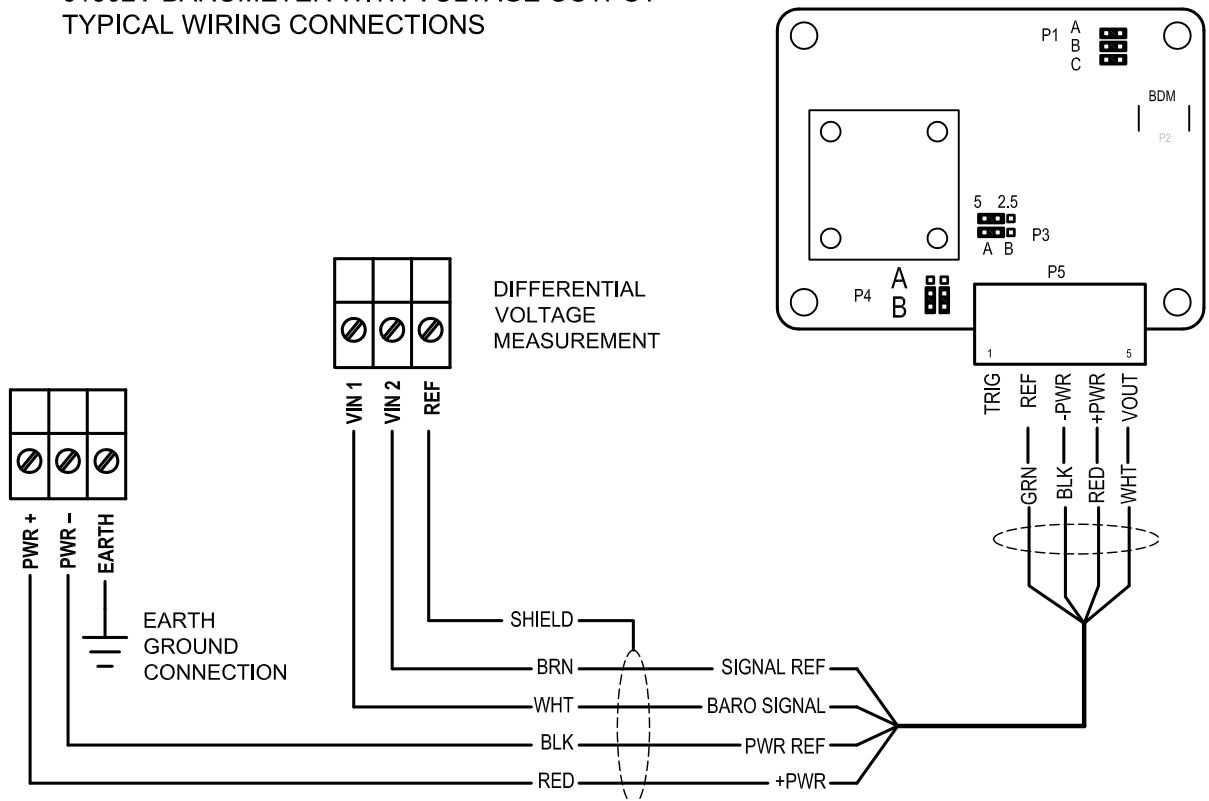

APPENDIX B

61302L BAROMETER WITH 4-20mA OUTPUT TYPICAL WIRING CONNECTIONS

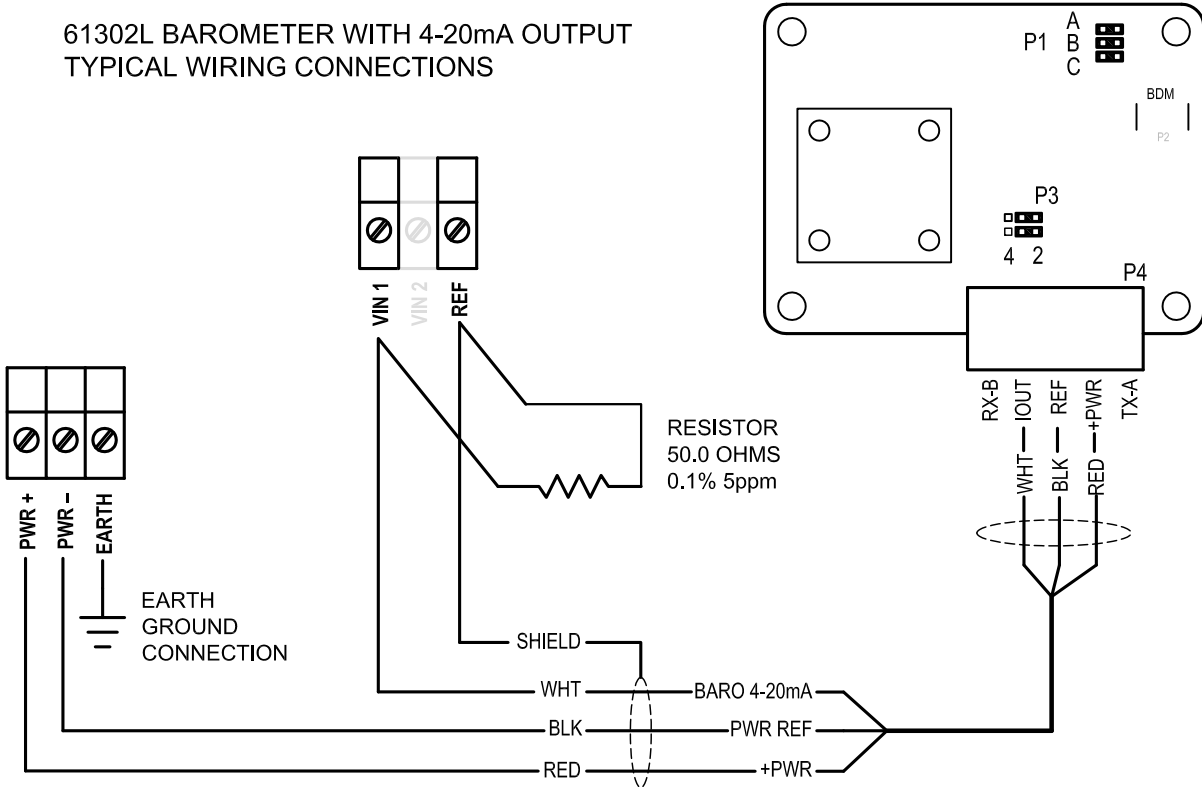

61302L BAROMETER WITH RS-485 OUTPUT TYPICAL WIRING CONNECTIONS

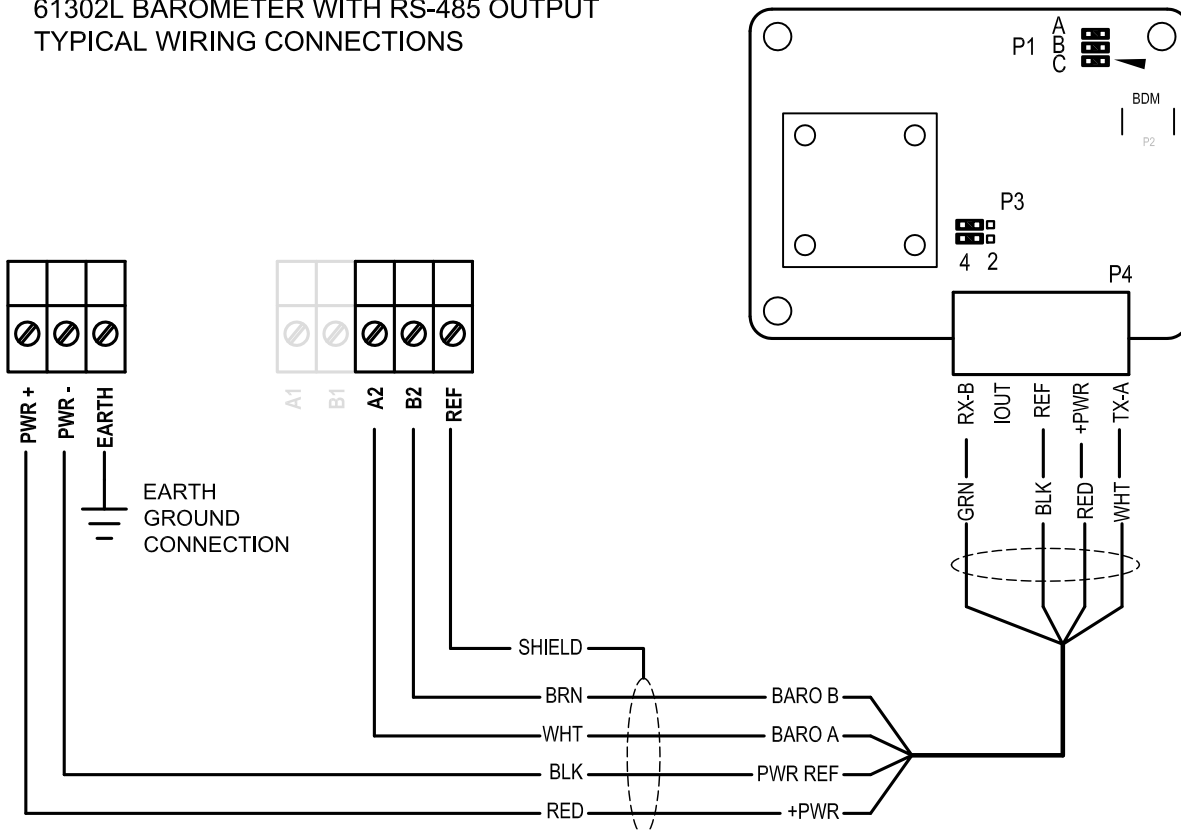

APPENDIX B

52202, 52203 TIPPING BUCKET RAIN GAUGE TYPICAL WIRING CONNECTIONS

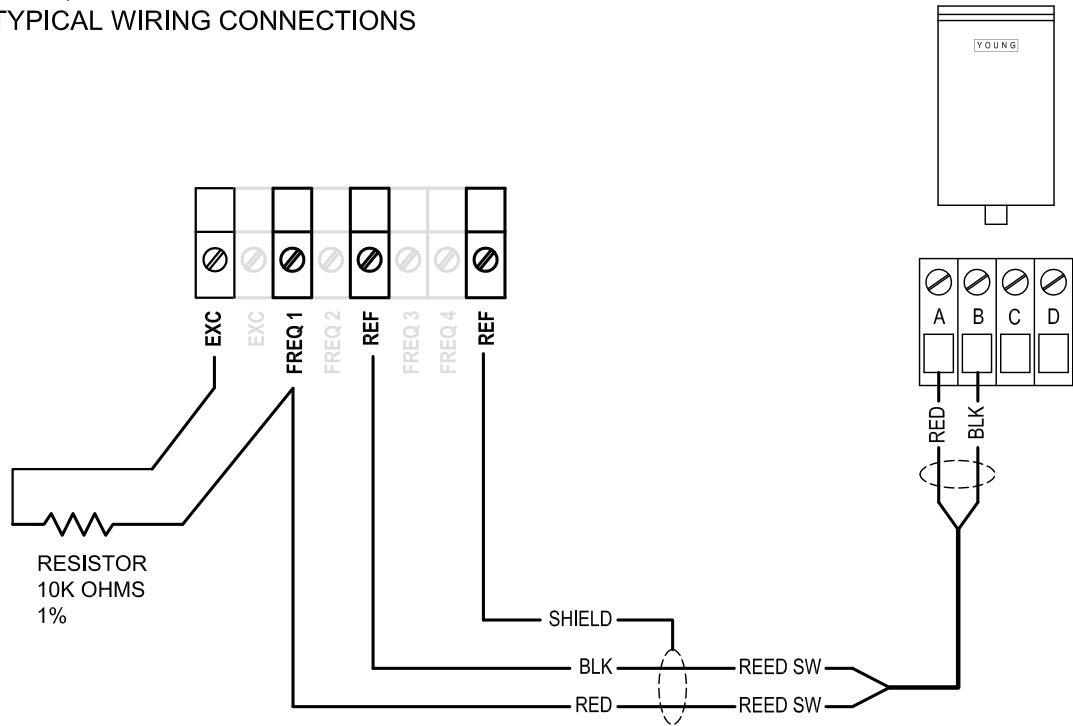

50202, 50203 PRECIPITATION GAUGE WITH VOLTAGE OUTPUT TYPICAL WIRING CONNECTIONS

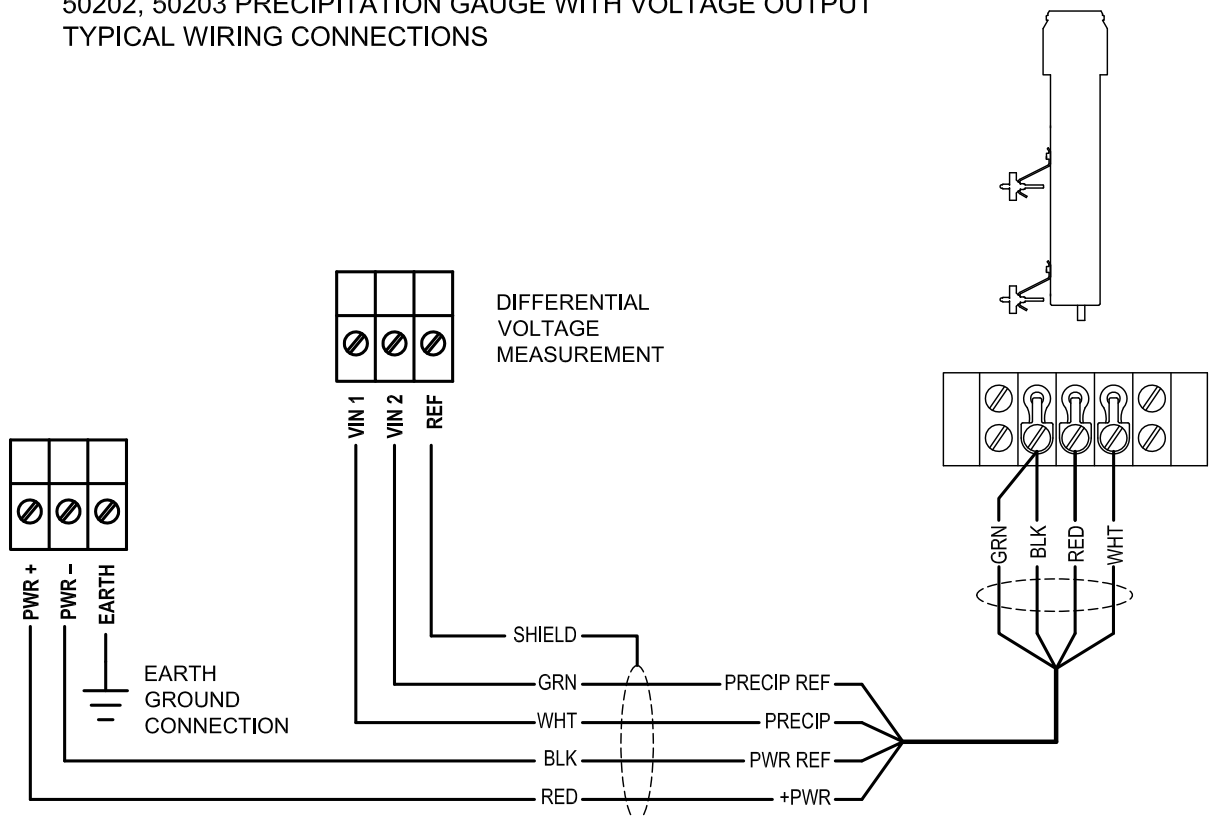

APPENDIX B

70090 PYRANOMETER TYPICAL WIRING CONNECTIONS

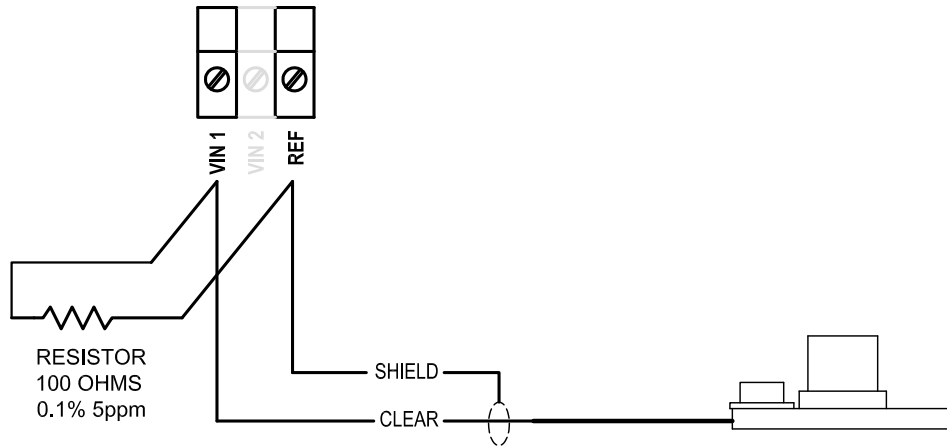

APPENDIX C

EXAMPLE USER PROGRAM

This program takes wind speed and direction measurements from a Young 05103 Wind Monitor and Temperature/RH measurements from a Young 41382V Temp/RH Sensor.

The execution interval is set to 1 iteration per second. Instantaneous measurements are displayed on screen 1. Averages for all values and maximum wind speed are calculated and recorded once per minute.

```

INPUT WIND SPEED (FREQ)      Wind speed signal input on FREQ
  chan= 01                   channel 01. Result stored in DLOC
  sensor= 051xx              001
  units= M/S
  dloc= 001

INPUT WIND DIR (VOLTAGE)    Wind direction signal input on
  chan= 01                   VIN1. Result stored in DLOC 002.
  sensor= 051xx
  dloc= 002

INPUT VOLTAGE               0-1V Temperature signal measured
  chan= 05                   on differential VIN pair 5/6 at a
  type= DIFF                 rate of 60Hz. MULT and OFFS
  mult= 0.10000             scale signal to -50 to +50 C. Result
  offs= -50.000             stored in DLOC 003.
  rate= 60Hz
  dloc= 003

INPUT VOLTAGE               0-1V RH signal measured on differ-
  chan= 07                   ential VIN pair 7/8 at a rate of 60Hz.
  type= DIFF                 MULT and OFFS scale signal to 0
  mult= 0.10000             to 100% RH. Result stored in DLOC
  offs= 0.00000            004.
  rate= 60Hz
  dloc= 004

DISPLAY VALUE               Wind speed in SLOC 001 displayed
  sloc= 001                 on screen 1 using big font at row/
  scrn= 1                   column 1/02. WIDTH and DECPT
  font= BIG                 define 00.0 format.
  row= 1
  col= 02
  width= 4
  decpt= 1

DISPLAY VALUE               Wind direction in SLOC 002 dis-
  sloc= 002                 played on screen 1 using big font
  scrn= 1                   at row/column 1/07. WIDTH and
  font= BIG                 DECPT define 000 format.
  row= 1
  col= 07
  width= 3
  decpt= 0

DISPLAY VALUE               Temperature in SLOC 003 display-
  sloc= 003                 ed on screen 1 using big font at
  scrn= 1                   row/column 1/11. WIDTH and
  font= BIG                 DECPT define 000.0 format.
  row= 1
  col= 11
  width= 5
  decpt= 1

DISPLAY VALUE               RH in SLOC 004 displayed on
  sloc= 004                 screen 1 using big font at row/
  scrn= 1                   column 1/17. WIDTH and DECPT
  font= BIG                 define 000 format.
  row= 1
  col= 17
  width= 3
  decpt= 0

```

```

IF TIME INTERVAL
  unit= MIN
  time= 0001
FLAG SET
  flag#= 01
  state= ON
END IF

```

```

AVERAGE
  sloc= 001
  dloc= 011
  type= BLOCK
  #samp= 00000
AVERAGE
  sloc= 002
  dloc= 012
  type= BLK ANGLE
  #samp= 00000
AVERAGE
  sloc= 003
  dloc= 013
  type= BLOCK
  #samp= 00000
AVERAGE
  sloc= 004
  dloc= 014
  type= BLOCK
  #samp= 00000
MAXIMUM
  sloc= 001
  dloc1= 021
  type= BLOCK
  #samp= 00000

```

```

IF FLAG
  flag#= 01
  state= ON
RECORD TIME
  frmt= DATE
RECORD TIME
  frmt= TIME
RECORD VALUE
  sloc= 011
RECORD VALUE
  sloc= 012
RECORD VALUE
  sloc= 013
RECORD VALUE
  sloc= 014
RECORD VALUE
  sloc= 022
END IF

FLAG SET
  flag#= 01
  state= OFF

PGM END

```

Flag 1 is set when the top of the minute (00 seconds into the minute) is reached. We'll use this flag to align our statistical calculations and data recording with uniform time intervals.

END IF for IF TIME INTERVAL

The AVERAGE and MAXIMUM instructions process values from their respective SLOCs. Because we use BLOCK type, the resulting calculations are controlled by FLAG 1 rather than #SAMP. Note that wind direction average uses the BLK ANGLE type.

When time aligns with the top of the minute, record the average wind speed, wind direction, temperature, RH and maximum wind speed.

END IF for IF FLAG

Turn FLAG 1 OFF so statistical instructions can begin collecting new samples.

14.2	215	26.3	85
SPEED M/S	DIR deg	TEMP degC	RH%