

SAILOR® 150 FLEETBROADBAND

COBHAM

The flexible global connectivity and voice solution

2013 Product Sheet

The most important thing we build is trust

SAILOR 150 FleetBroadband is a compact, lightweight, easy to install and affordable communication system that provides reliable internet access, email and multiple voice lines. Using the same proven technology as SAILOR's heavy-use FleetBroadband solutions, SAILOR 150 FleetBroadband combines internet connectivity with simultaneous voice calling, ideal for single users and general IP applications.

Stay connected

With SAILOR 150 FleetBroadband you always have a 150 kbps data connection available, so you can receive weather data and charts, or submit reports to shore at the same time as making calls or sending text messages. SAILOR 150 FleetBroadband helps you achieve increased efficiency; commercial owners can expand the opportunities for profit while reliable connectivity for cruisers provides safety and convenience anywhere in the world.

Simple and secure installation

SAILOR 150 FleetBroadband is easy and cost-effective to install, so professional and recreational users can be up and running within just a few hours. You'll have everything you need to get started in the box and because the system is based on standard IP services and clear user interface, connecting your computer or phone system is simple and safe.

A world of applications

In addition to single user connectivity, enabling you to stay in touch with friends, family and colleagues regardless of your location or the weather, SAILOR 150 FleetBroadband can be used for dedicated tracking and telemetry applications.

This advanced functionality helps to enhance efficiency by ensuring your support on shore has all the information they need, from real-time engine data for maintenance to position data for vessel tracking.

Multiple voice lines

With up to four simultaneous voice lines possible using the Inmarsat FleetBroadband Multi-voice service, you can turn your SAILOR 150 FleetBroadband into a multi-user voice solution. Combined with the Thrane IP Handset you get an even more flexible solution with access to a multitude of value added services.

Communicate with confidence

SAILOR products are highly regarded by maritime professionals for their design and build quality, which results in excellent reliability. To support this, we guarantee fast and dependable service through our established network of On Board Service Centers (OSC). With OSC locations all around the world, service and support is always available, whenever and wherever it is needed.



SAILOR® 150 FLEETBROADBAND

The flexible global connectivity and voice solution



SAILOR 150 FleetBroadband
Above Deck Unit (3,9 kg)

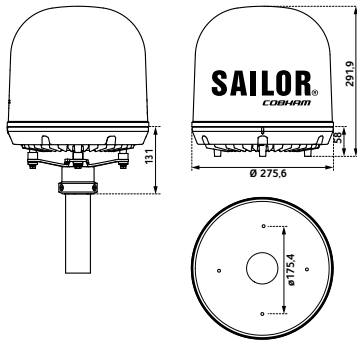

SAILOR 150 FleetBroadband
Below Deck Unit (2,0 kg)

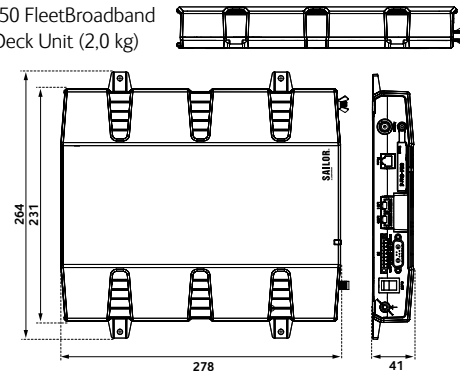

APPROVALS

Inmarsat FleetBroadband approved. Compliant to RTTE, CE Marked. Testet to FCC part 25

FREQUENCY BAND

Rx	1525.0 - 1559.0 MHz
Tx	1626.5 - 1660.5 MHz
Ch. width	10.5 - 189 kHz, Rx 21 - 189 kHz, Tx

RECOMMENDED ANTENNA CABLE

Cable loss max/min	20 dB at 1,62 GHz and 1.0 Ω DC loop resistance 3 dB at 36 - 4 dB at 54 MHz
--------------------	---

POWER SUPPLY AND CONSUMPTION

DC input range (isolated)	10 to 32V DC
Power (max).	120 W @ 10-32 V
incl. antenna & PoE output	

ENVIRONMENTAL CONDITIONS

Ambient Temperature	-25 to +55°C
Storage	-40 to +85°C
Survival (power on, non functional)	-40 to +80°C
Automatic thermal surveillance	shuts down system gradually in ease of own temperature
BDU operating humidity	95% non-condensing at +40°C
ADU enclosure	IPX6
ADU operating humidity	"Exposed" according to EN60 945
BDU enclosure	IP31
Icing (survival)	Max 25 mm

VIBRATION (ADU)

Vibration, operational	Random spectrum 1.05 g rms x 3 axes: 5 to 20 Hz: 0.02 g ² /Hz 20 to 150 Hz: -3 dB/octave
Vibration, non-operational	Random spectrum 1.7 g rms 2 h x 3 axes (6 h total): 5 to 20 Hz: 0.05 g ² /Hz, 20 to 150 Hz: -3 dB/octave

SHIP MOTION

Roll	+/- 30 deg. per. 4 s, max 0.7 g tan.
Pitch	+/- 15 deg. per. 3 s, max 0.6 g tan.
Yaw	+/- 10 deg. per. 5 s, max 0.3 g tan.
Surge	+/- 0.5g
Sway	+/- 0.5g
Heave	+/- 0.7g
Turning rate	+/- 36°/s; ACC 12°/s ²
Headway speed	22 m/s (42 knots)
Wind	100 knots

MECHANICAL SHOCK

20g/11 half-sine

ANTENNA CONNECTOR

ADU	TNC, female
BDU	TNC, female

COMPARISON CHART

	SAILOR 500 FleetBroadband	SAILOR 250 FleetBroadband	SAILOR 150 FleetBroadband
Standard IP	Up to 432 kbps	Up to 284 kbps	Up to 150 kbps
Streaming IP	8, 16, 32, 64, 128, 256 kbps	8, 16, 32, 64, 128 kbps	-
ISDN Data	64 kbps	-	-
Fax	G4 via UDI, G3 fax via 3.1 kHz Audio	G3 fax via 3.1 kHz Audio	G3 fax via 3.1 kHz Audio
SMS (standard 3G)	160 characters	160 characters	160 characters
Standard Voice	4 kbps	4 kbps	4 kbps
Premium Voice	3.1 kHz Audio, 64 kbps	3.1 kHz Audio, 64 kbps	3.1 kHz Audio, 64 kbps
Multi-voice	9 voice lines simultaneously	6 voice lines simultaneously	4 voice lines simultaneously
Ethernet/PoE	4 ports	4 ports	2 ports
Phone/Fax (2-wire)	2 ports	2 ports	1 port
ISDN	1 port (data/3.1 kHz Audio)	1 port (3.1 kHz Audio)	-
I/O Connector	1 connector with 5 configurable inputs/outputs	1 connector with 5 configurable inputs/outputs	1 connector with 5 configurable inputs/outputs
L-Band Output	1 port for L-Band Broadcast service	1 port for L-Band Broadcast service	1 port for L-Band Broadcast service
Status LED	Full status LED panel	Full status LED panel	Full status LED panel
SIM Card Slot	1 SIM Card slot for BGAN SIM card	1 SIM Card slot for BGAN SIM card	1 SIM Card slot for BGAN SIM card
Router	Integral DHCP/NAT router	Integral DHCP/NAT router	Integral DHCP/NAT router
PBX	Built-in PBX	Built-in PBX	Built-in PBX

For further information please contact:

Cobham SATCOM Maritime
Lundtoftegaardsvej 93 D
DK-2800 Kgs. Lyngby
Denmark
www.cobham.com
Tel: +45 3955 8800
Fax: +45 3955 8888